

Recommended P.C.B. Layout

**SPECIFICATION**

Current Rating:1 Amp Max.  
 Operation Voltage:150V AC Max.  
 Withstand Voltage:500V AC RMS  
 Contact Resistance:20 Milliohms Max.  
 Insulation Resistance:500 Megaohms Min.  
 Operation Temperature:-40°C~+85°C  
 Insulator&Cap:PA9T(UL94V-0),Nature  
 Contact:Brass,Bright Tin Plated Over Nickel  
 Locating:Brass,Bright Tin Plated Over Nickel  
 RoHS Compliant

FH XX V C - R1K - H  
 (1) (2) (3) (4) (5) (6)

- (1) FH:1.25 FH Series
- (2) XX:No. Of Position
- (3) V:SMT Straight
- (4) C:With Cap
- (5) R1K:Tape&Reel 1000 PCS/Reel
- (6) H:RoHS Compliant

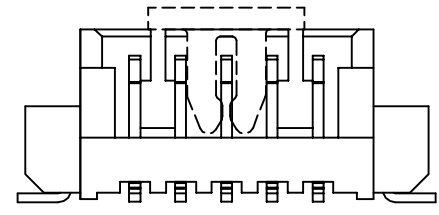
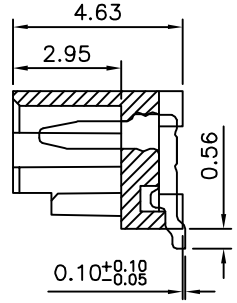
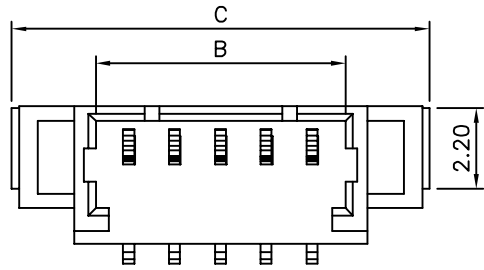

Odd Number

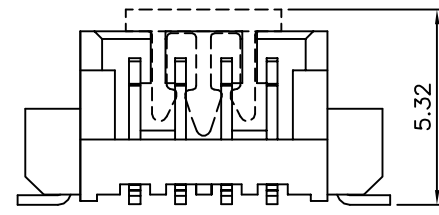
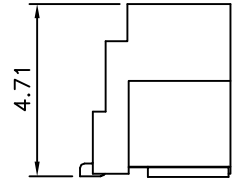
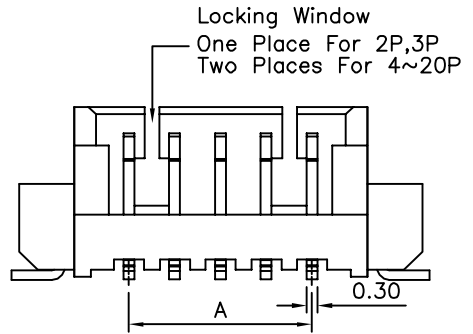

Dual Numbers

Pin	A	B	C
2	1.25	3.05	7.65
3	2.50	4.30	8.90
4	3.75	5.55	10.15
5	5.00	6.80	11.40
6	6.25	8.05	12.65
7	7.50	9.30	13.90
8	8.75	10.55	15.15
9	10.00	11.80	16.40
10	11.25	13.05	17.65
11	12.50	14.30	18.90
12	13.75	15.55	20.15
13	15.00	16.80	21.40
14	16.25	18.05	22.65
15	17.50	19.30	23.90
16	18.75	20.55	25.15
17	20.00	21.80	26.40
18	21.25	23.05	27.65
19	22.50	24.30	28.90
20	23.75	25.55	30.15

**AUK** A MEMBER OF AUK GROUP  
**太聯事業股份有限公司**  
**AUK CONTRACTORS CO., LTD.**

CATEGORY		APPROVED BY		UNLESS OTHERWISE SPECIFIED TOLERANCES ARE .X ±0.30 .XX ±0.20 ANG.
PART No. FHXXVC-R1K-H		EMILY		
DRAWING No. FHXXVC-R1K-H		CHECKED BY HZF		
SCALE NONE		DRAWING BY GAO		
REV.	A1	UNIT mm		

NO.	REV.	REVISIONS	CHK	DATE
△ A1		Modify Data	HZF	02/20/2013
△ A0		NEW RELEASE	HZF	05/07/2012



**SPECIFICATION**  
 Q'ty:1000 PCS/Reel  
 RoHS Compliant

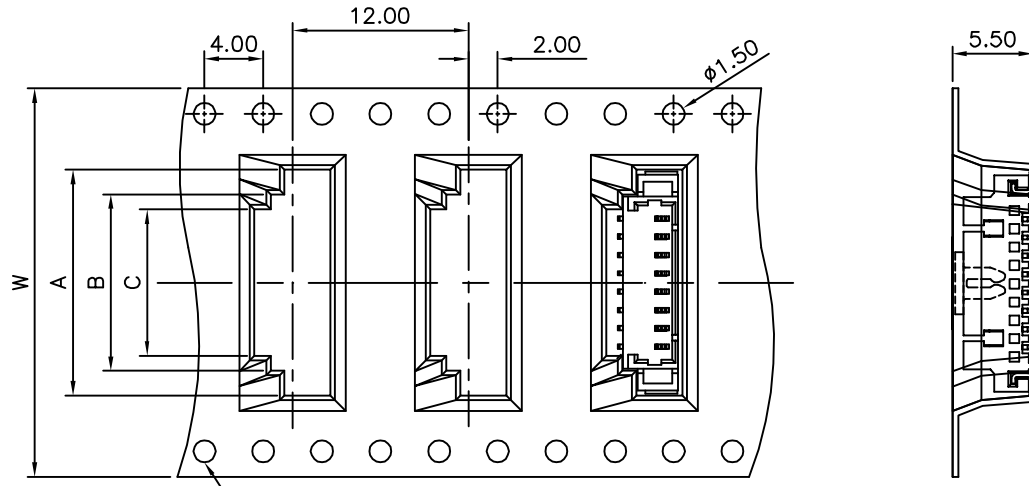

When W>32.00mm(Include W=32.00mm),  
 The Bottom Hole Of Tape Will Be Shown

Pin	A	B	C	W
2	7.90	4.55	2.50	16.0
3	9.15	5.80	3.75	24.0
4	10.40	7.05	5.00	
5	11.65	8.30	6.25	
6	12.90	9.55	7.50	
7	14.15	9.80	8.75	32.0
8	15.40	11.05	10.00	
9	16.65	12.30	11.25	
10	17.90	13.55	12.50	
11	19.15	14.80	13.75	44.0
12	20.40	16.05	15.00	
13	21.65	17.30	16.25	
14	22.90	18.55	17.50	
15	24.15	19.80	18.75	
16	25.40	21.05	20.00	
17	26.65	22.30	21.25	
18	27.90	23.55	22.50	
19	29.15	24.80	23.75	
20	30.40	26.05	25.00	

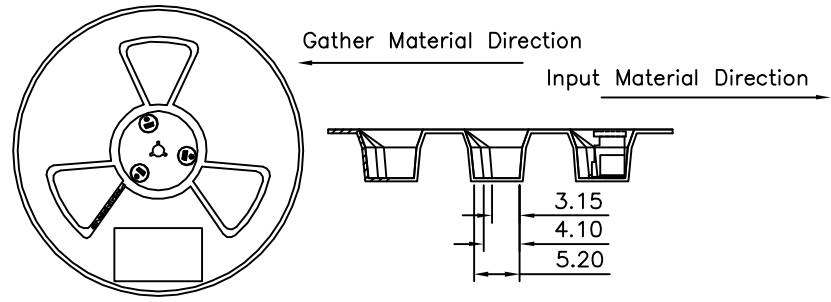

**AUK** A MEMBER OF AUK GROUP  
**太聯事業股份有限公司**  
**AUK CONTRACTORS CO., LTD.**

CATEGORY		APPROVED BY		UNLESS OTHERWISE SPECIFIED TOLERANCES ARE .X ±0.3 .XX ±0.2 .XXX ±0.1
PART No. FHXXVC-R1K-H		EMILY		
DRAWING No. FHXXVC-R1K-H		CHECKED BY HZF		
SCALE		DRAWING BY GAO		
SCALE	NONE	REV.	A1	UNIT mm

NO.	REV.	REVISIONS	CHK	DATE
△A1		Modify Data	HZF	02/20/2013
△A0		NEW RELEASE	HZF	05/07/2012