

Recommended P.C.B. Layout

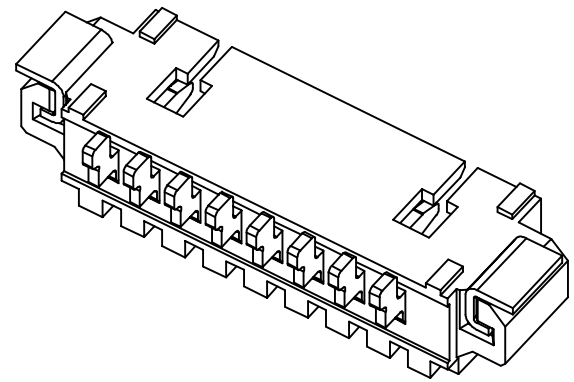

SPECIFICATION

Current Rating:1 Amp Max.
 Operation Voltage:150V AC Max.
 Withstand Voltage:500V AC RMS
 Contact Resistance:20 Milliohms Max.
 Insulation Resistance:500 Megaohms Min.
 Operation Temperature:-40°C~+85°C
 Insulator:PA9T(UL94V-0),Nature
 Contact:Brass,Matte Tin Plated Over Nickel
 Locating:Brass,Matte Tin Plated Over Nickel
 RoHS Compliant

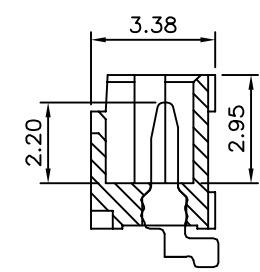
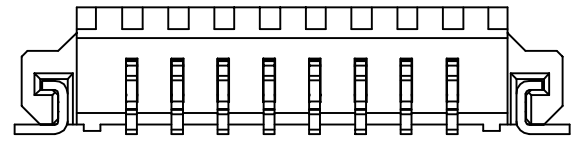
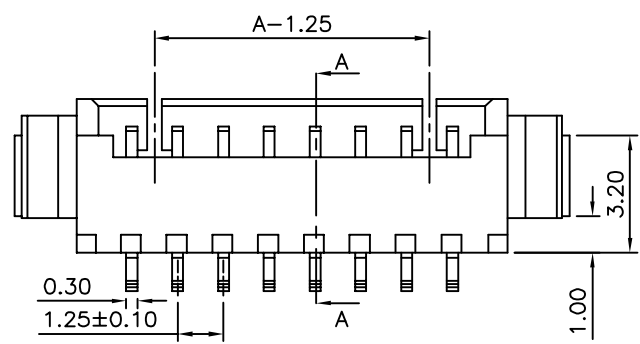
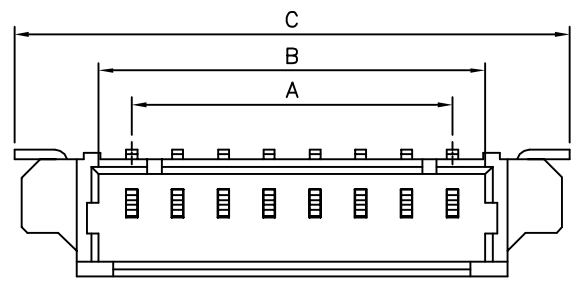

Section A-A

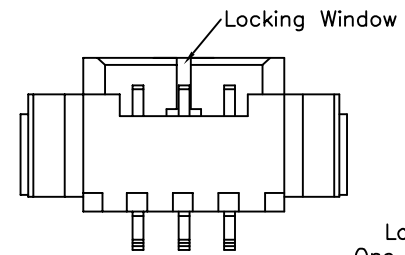
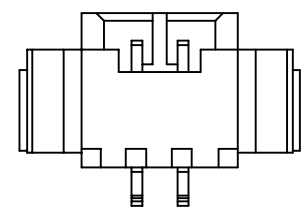
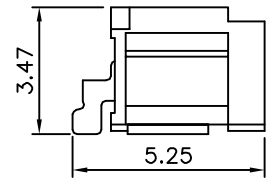

Locking Window
 One Place For 2P,3P
 Two Places For 4~20P

FH XX W - R1K - H
 (1) (2) (3) (4) (5)

- (1) FH:1.25 FH Series
- (2) XX:No. Of Position
- (3) W:SMT Right Angle
- (4) R1K:Tape & Reel 1000 PCS/Reel
- (5) H:RoHS Compliant

Pin	A	B	C
2	1.25	3.05	7.65
3	2.50	4.30	8.90
4	3.75	5.55	10.15
5	5.00	6.80	11.40
6	6.25	8.05	12.65
7	7.50	9.30	13.90
8	8.75	10.55	15.15
9	10.00	11.80	16.40
10	11.25	13.05	17.65
11	12.50	14.30	18.90
12	13.75	15.55	20.15
13	15.00	16.80	21.40
14	16.25	18.05	22.65
15	17.50	19.30	23.90
16	18.75	20.55	25.15
17	20.00	21.80	26.40
18	21.25	23.05	27.65
19	22.50	24.30	28.90
20	23.75	25.55	30.15

AUK A MEMBER OF AUK GROUP
太聯事業股份有限公司
AUK CONTRACTORS CO., LTD.

CATEGORY		APPROVED BY		UNLESS OTHERWISE SPECIFIED TOLERANCES ARE .X ±0.35 .XX ±0.20 ANG.					
PART No. FHXXW-R1K-H		MEI							
DRAWING No. FHXXW-R1K-H		CHECKED BY HZF							
		DRAWING BY GAO							
SCALE	NONE	REV.	AO	UNIT mm		△ AO	NEW RELEASE	HZF	05/07/2012
						NO.REV.	REVISIONS	CHK	DATE

SPECIFICATION
 Q'ty:1000 PCS/Reel
 RoHS Compliant

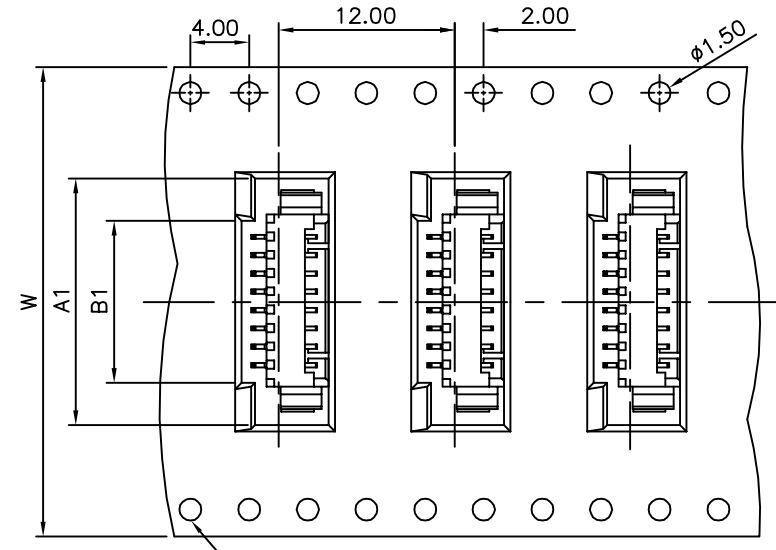

When $W > 32.00\text{mm}$ (Include $W = 32.00\text{mm}$),
 The Bottom Hole Of Tape Will Be Shown

Pin	A1	B1	W
2	8.05	3.55	16.0
3	9.30	4.80	
4	10.45	6.05	
5	11.80	7.30	24.0
6	13.05	8.55	
7	14.30	9.80	
8	15.45	9.80	
9	16.40	11.05	
10	18.05	12.30	32.0
11	19.30	13.55	
12	20.55	14.80	
13	21.80	16.05	
14	23.05	17.30	44.0
15	24.30	18.55	
16	25.55	19.80	
17	26.80	21.05	
18	28.05	22.30	
19	29.30	23.55	
20	30.55	24.80	

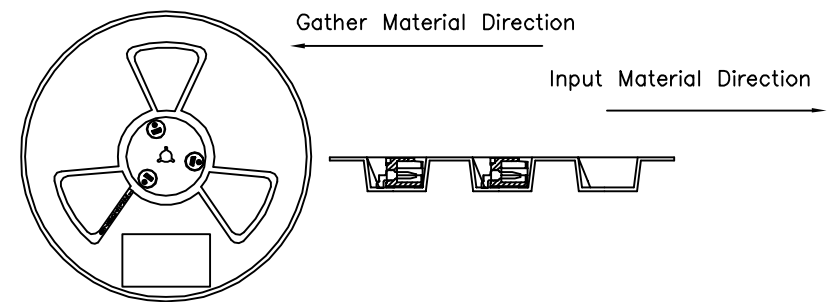

AUK A MEMBER OF AUK GROUP
太聯事業股份有限公司
AUK CONTRACTORS CO., LTD.

CATEGORY		APPROVED BY MEI		UNLESS OTHERWISE SPECIFIED TOLERANCES ARE .X ±0.3 .XX ±0.2 .XXX ±0.1
PART No. FHXXW-R1K-H		CHECKED BY HZF		
DRAWING No. FHXXW-R1K-H		DRAWING BY GAO		
SCALE	NONE	REV.	A0	
UNIT	mm			NO. REV.

△ A0	NEW RELEASE	HZF	05/07/2012
NO. REV.	REVISIONS	CHK	DATE