

REV.	DESCRIPTION	DRAWN	CHECKED	APPROVED
A	NEW RELEASE	YCH 06/04/07'		

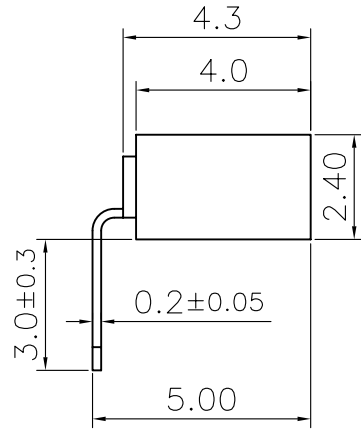

NOTES:

- ELECTRICAL CHARACTERISTICS:
 - CONTACT RESISTANCE: 20mΩ Max. INITIAL.
 - DIELECTRIC WITHSTANDING VOLTAGE: 500V AC(rms) FOR 1 MINUTE.
 - INSULATION RESISTANCE: 1000MΩ Min.
- ENVIRONMENT CHARACTERISTICS:
 - TEMPERATURE: -40°C~+105°C.
- PART NUMBER: DS1026-15
- PRODUCT NUMBER CODE:

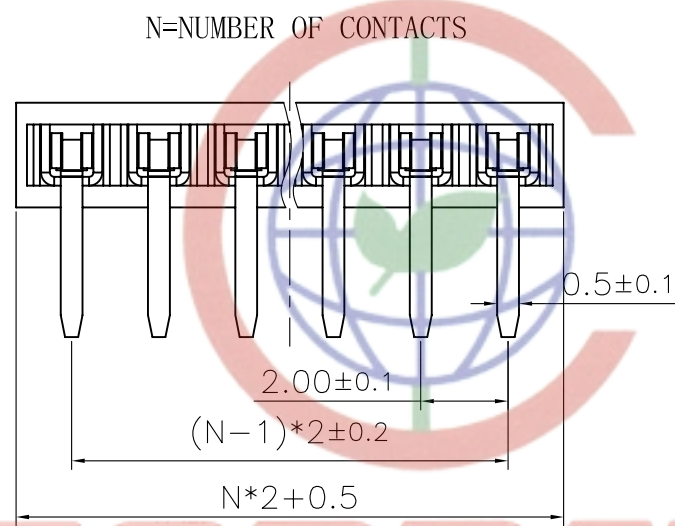
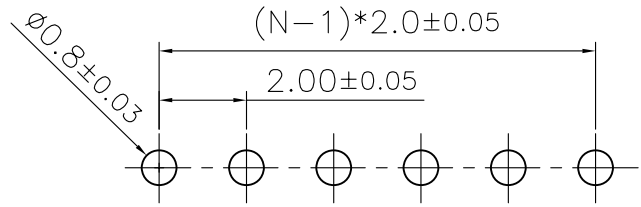
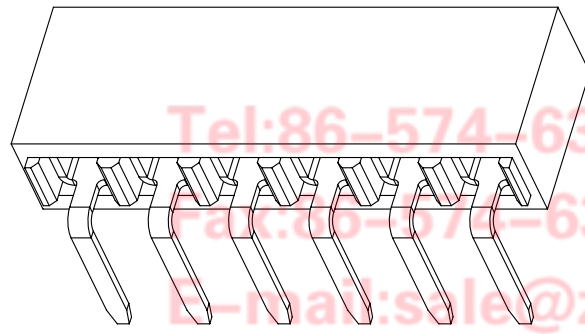
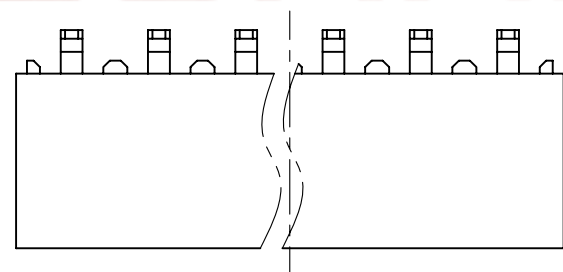
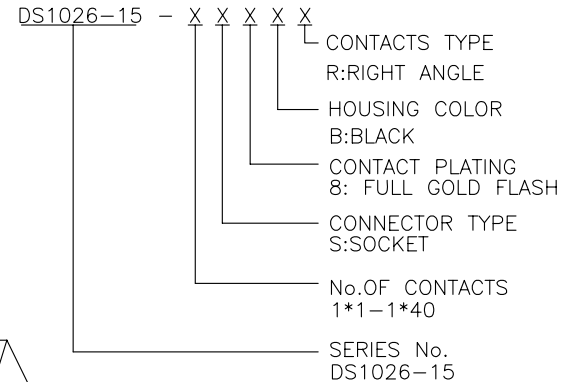

Recommend PCB layout

GENERAL TOLERANCE		ANGLE TOLERANCE		PROJECTION		TITLE
X.	±0.60	X.	±5°	UNITS	mm	FEMALE HEADER PITCH 2.00mmTYPE
.X	±0.38	.X	±3°	SHEET SIZE	A4	SERIES DS1026-15 SERIES
.XX	±0.25	.XX	±2°			
DRAWING TYPE		CUSTOMRE				
SCALE		1:1	SHEET	1 OF 1		
DRAWING NO.		DS1026-15-XXXXX-A				

晨翔电子有限公司
CONNFLY CONNFLY ELECTRONIC CO. LTD

Tel:86-574-63508787
Fax:86-574-63510817
E-mail:sale@zhenqin.com.cn

Http://www.connfly.com
Add:East Industry Zone RuangYan
P.O.315333