



RoHS Compliant
Directive 2011/65/EU

SPECIFICATION

Customer: ELTECH NPP NEFTESERVISPRIBOR

Item:	Crystal Unit
Type:	NX3225SA
Nominal Frequency:	22.1184 MHz
Customer's Spec. No.:	NX3225SA-22.1184MHz
NDK Spec. No.:	S1-40125-5015-8

Receipt

Charge:

Sales	NDK ITALY SRL P.Bandera	Tel. : 39-02-96702920 e-Mail : bandera@it.ndk.com
Engineer	1 st Eng. Dept. N.Wakisaka	Tel. : 81-4-2900-6631 e-Mail : wakisaka@ndk.com

Revision Record

Rev.	Date	Items	Contents	Approved	Checked	Drawn
---	17.Mar.2014	Issue	---	H.Kobayashi	N.Yamamoto	N.Wakisaka

1. Customer's Spec. No. :
2. NDK Spec. No. : EXS00A-CS07797
3. Type : NX3225SA
4. Electrical Specifications

	Parameters	SYM.	Electrical Spec.				Units	Notes
			min	typ	max			
1	Nominal frequency	f_{nom}	22.1184			MHz		
2	Overtone order	-	Fundamental			-		
3	Frequency tolerance	-	-15	-	+15	ppm	at +25°C	
4	Frequency versus temperature characteristics	-	-50	-	+50	ppm	at -40~+125°C The reference temperature shall be +25°C	
5	Equivalent resistance	-	-	-	100	Ω	IEC π -Network Series	
6	Load capacitance	C_L	-	8	-	pF	IEC π -Network	
7	Level of drive	-	-	10	200	μ W		
8	Insulation resistance	-	500	-	-	M Ω	When terminal to terminal and terminal to cover were applied at DC100V \pm 15V.	
9	Operating temperature range	T_{opr}	-40	-	+125	°C		
10	Storage temperature range	T_{str}	-40	-	+125	°C		
11	Air-tightness	-	-	-	1.1×10^{-9}	Pa m ³ /s	Helium leak detector	

5. Examination results document

The examination results document is submitted every shipment lot.

6. Application drawing

- 6.1 External dimension : EXD14B-00370
- 6.2 Taping and reel figure : EXK17B-00098
- 6.3 Holder marking : EXH11B-00317
- 6.4 Reliability assurance Item : EXS30B-00499
- 6.5 Recommendation reflow profile : EXS30B-00344

7. Notice

- 7.1 Order items are manufactured according to specification. As to conditions, which are not indicated in this specification and unpredictable such as applied condition and oscillation margin, please check them beforehand.
- 7.2 Unless we receive request for modification within 3 weeks from the issue date of this NDK specification sheet, we will supply products according to this specification. Also, if you'd like to modify specification of order, which has been placed with delivery request within 3 weeks from the issue data of this specification sheet, we would like to discuss with you separately.
- 7.3 In no event shall the company be liable for any product failure resulting from an inappropriate handling or operation of the product beyond the scope of its guarantee.
- 7.4 Where any change to the process condition is made due to the change(s) in the production line, inform personnel of the specifications.
- 7.5 Should this specification data give rise to any disputes relating to any intellectual property rights or any other rights of a third person, the company shall not indemnify anyone for any damage. Their disclosure must not be construed as the grant of a license to use any of the intellectual property rights owned by the company.
- 7.6 If you intend to use products listed on this specification for applications that may result in loss of life or assets (controls relating to safety, medical equipment, aeronautical equipment, space equipment, etc.), please do not fail to advise us of your intention beforehand.
- 7.7 In the company's production process whatever amount of ozone depleting substances (ODS) as specified in the Montreal protocol is not used.
- 7.8 Information contained in this specification must not be quoted, reproduced or used for other purposes including processing either in part or in full without obtaining prior approval from the company.
- 7.9 Crystal units will be damaged by ultrasonic welding process due to resonance of crystal wafer itself. NDK does not recommend using ultrasonic welding. If Ultra Sonic welding used, NDK strongly recommend verifying crystal unit damage by ultrasonic weld.

8. Prohibited items

Be sure to use the product under the following conditions. Otherwise, the characteristics deterioration or destruction of the product may result.

(1) Reflow soldering heat resistance

Peak temperature: 265°C, 10 sec

Heating: 230°C or higher, 40 sec

Preheating: 150°C to 180°C, 120 sec

Reflow passage times: twice

(2) Manual soldering heat resistance

Pressing a soldering iron of 400°C on the terminal electrode for four seconds (twice).

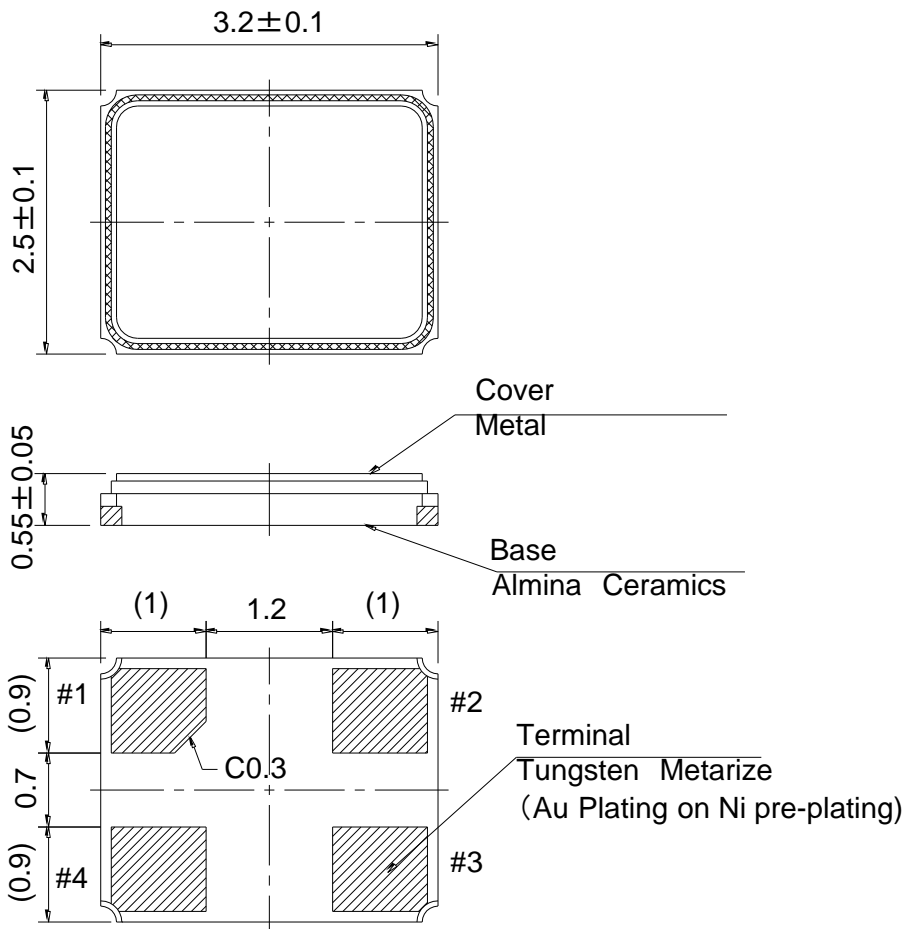

LAND PATTERN (TYPICAL)

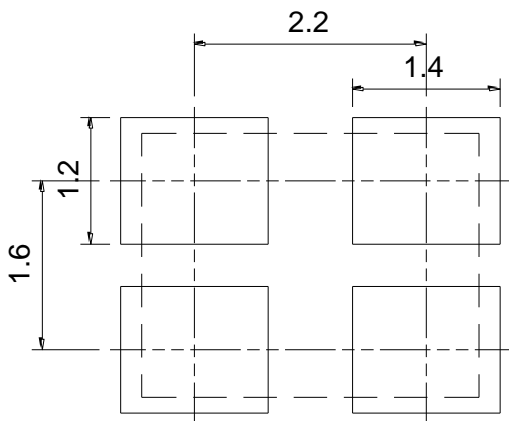

PIN CONNECTION (TOP VIEW)

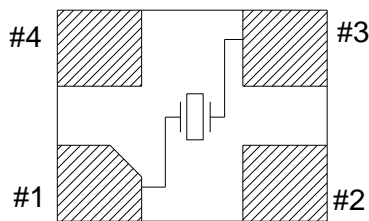

※ #1,#3 : Xtal
 #2,#4 : GND (CONNECTION COVER)

	Date of Revise	Charge	Approved	Reason
A	4.Sep.2007	R.Shariman	K.Kubota	Add Tolerance.
	Date	Name	Third Angle Projection	Tolerance
Drawn	25.Oct.2005	S.Mizusawa	Dimension:mm	±0.1
Designed	25.Oct.2005	S.Mizusawa	Title	Drawing No.
Checked			NX3225SA Dimension Drawing	EXD14B-00370
Approved	25.Oct.2005	S.Mizusawa		
				A

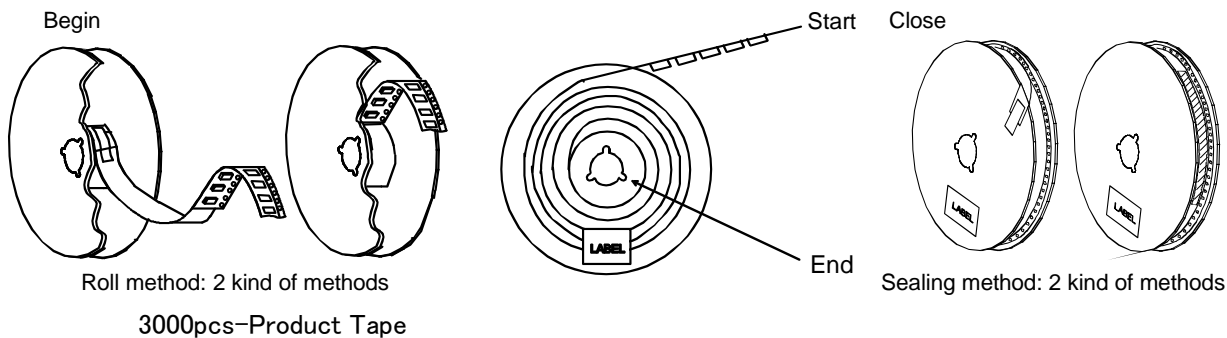
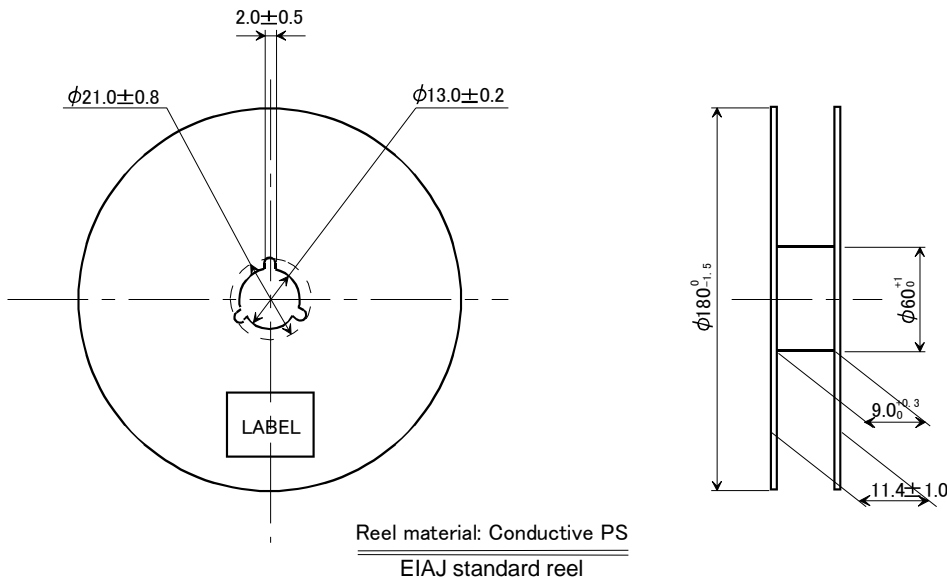
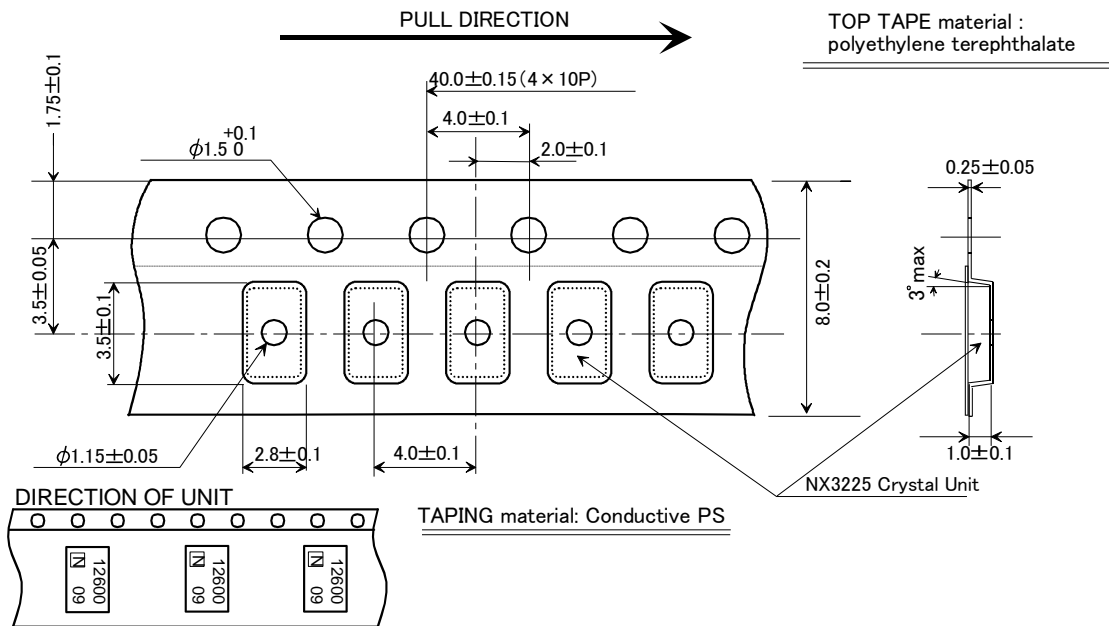

	Date of Revise	Charge	Approved	Reason
I	22 Aug. 2012	T. Shimizu	K. Oguri	Top cover tape leader line was deleted.
	Date	Name	Third Angle Projection	Tolerance
Drawn	3.Sep.2001	K.Oguri	Dimension:mm	Scale
Designed	3.Sep.2001	K.Oguri	Title	Drawing No.
Checked			NX3225 Series Taping and Reel Spec.	EXK17B-00098
Approved	3.Sep.2001	K.Miyashita		
				I

NIHON DEMPA KOGYO CO., LTD.

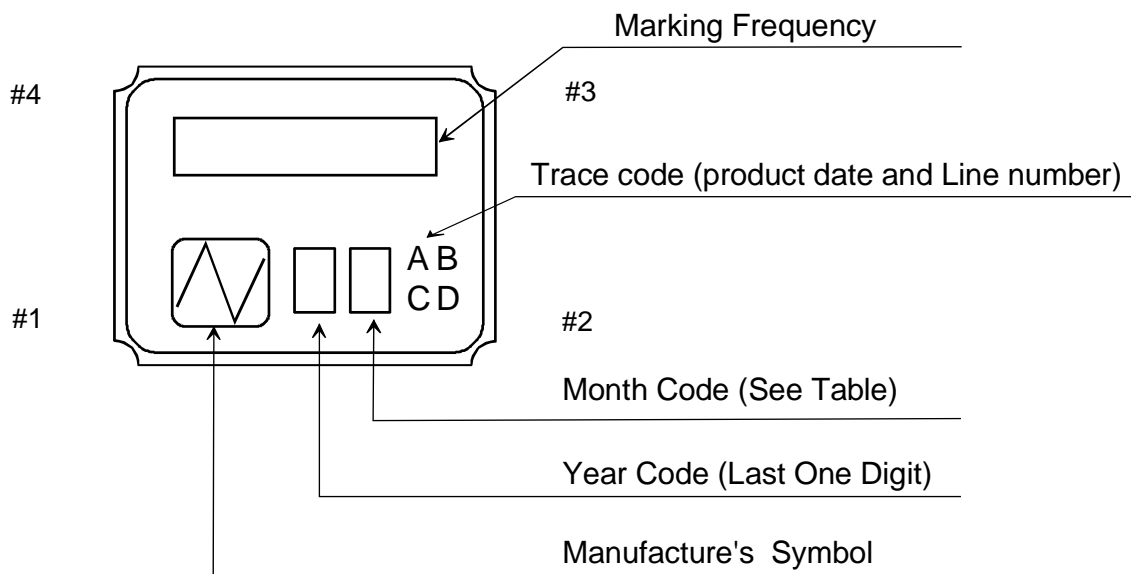

NOTE

1. Frequency Code

Marking Frequency is consist of five digits, first five digits of Nominal Frequency

Example

Nominal Frequency	28.636363 MHz
Frequency Code	28.636

2. Month Code Table

Month	1 Jan.	2 Feb.	3 Mar.	4 Apr.	5 May.	6 Jun.	7 Jul.	8 Aug.	9 Sep.	10 Oct.	11 Nov.	12 Dec.
Month Code	1	2	3	4	5	6	7	8	9	X	Y	Z

*Marking digits are not include a decimal point and dot mark.

	Date of Revise	Charge	Approved	Reason	
B	10.July.2008	Miyahara	K.Kubota	Delete application period.	
	Date	Name	Third Angle Projection	Tolerance	Scale
Drawn	16.Jan.2006	I.Miyahara	Dimension:mm		/
Designed	16.Jan.2006	I.Miyahara	Title	Drawing No.	Rev.
Checked	16.Jan.2006	---	Crystal Holder Marking	EXH11B-00317	B
Approved	16.Jan.2006	K.Okamoto			

NIHON DEMPA KOGYO CO., LTD.

Reliability assurance item

(page: 1/1)

No.	Test Item	Test Methods	Specification Code
1	High Temperature Storage	+125±3°C 1000h	A,D
2	Low Temperature Storage	-40±3°C 1000h	A,D
3	Temperature Humidity	+85±3°C 80~85%RH 1000h	A,D
4	Temperature Cycling	-55±5°C / +125±5°C It is 1000 cycles using 30 minutes each as 1 cycle.	A,D
5	Vibration	Frequency Range : 10~2000Hz Amplitude or Acceleration : 1.52mm or 196m/s ² 1 cycle : 20 minutes Test time : Three mutually perpendicular axes each 4 hours.	B,D
6	Shock	Devices are shocked to half sine wave (49000m/s ² , 0.15msec) six mutually perpendicular axis each 1 times.	B,D
7	Drop	Devices are dropped from the height 75cm onto iron plate. Execution 3 times random drops.	B,D
8	Solderability	Pre-heat temperature : +150±10°C Pre-heat time : 60~120s When the temperature of the specimen is reached at +215±3°C, it shall be left for 30±1sec. Material: H63A (Silver 2~3%) Flux : Rosin resin methyl alcohol solvent (1 : 4)	C
9	Reflow resistance	Pre-heat temperature : +150~180°C Pre-heat time : 90±30s Heat temperature : more than +230°C Pre-heat time : less than 30s Peak temperature : +260±5°C Peak time : less than 10s	B,D

Specification code	Specification
A	$\Delta f/f \leq \pm 20$ ppm $\Delta CI/CI \leq \pm 15\%$ or 5 Ω make use larger value
B	$\Delta f/f \leq \pm 10$ ppm $\Delta CI/CI \leq \pm 15\%$ or 5 Ω make use larger value
C	The electrodes should be covered by a new solder at least 90% of immersed area.
D	After testing unless cracking of materials view of eyes and unless break of seal.

Recommendation reflow condition

1.IR reflow condition

