



ISO9001 & ISO14001 & TS16949 **CHILISIN ELECTRONICS CORP.**

Lead-Free & RoHs Compliance!!

SPECIFICATION FOR APPROVAL

CUSTOMER : _____

CUSTOMER P/N : _____

OUR DWG No : _____

QUANTITY : 0 Pcs. **DATE :** 2013/05/21

ITEM : NLC252018T-3R3K-N

SPECIFICATION ACCEPTED BY:	
COMPONENT ENGINEER	
ELECTRICAL ENGINEER	
MECHANICAL ENGINEER	
APPROVED	
REJECTED	

<p>奇力新電子股份有限公司 CHILISIN ELECTRONICS CORP. NO.29,LANE 301,TEHHSIN ROAD,HUKOU, HSINCHU,TAIWAN,303, REPUBLIC OF CHINA TEL : (03) 599-2646 FAX : (03) 599-9176 E-mail : Sales@chilisin.com.tw http : //www.chilisin.com.tw</p> <p>台北營業處 Taipei Office 1F., No.2, Aly. 1, Ln. 235, Baoqiao Rd., Xindian Dist., New Taipei City 231, Taiwan TEL : +886-2-6629-5588~9 FAX : +886-2-6629-0088 E-mail : Sales@chilisin.com.tw</p>	<p>東莞奇力新電子有限公司 Chilisin Electronics (Dongguan) Co., Ltd. No. 78, Puxing Rd., Yuliangwei Administration Area, Qingxi Town, Dongguan City, Guangdong,China TEL : +86-769-8773-0251~3 FAX : +86-769-8773-0232 E-mail : cect@chilisin.com.tw</p> <p>奇力新電子(蘇州)有限公司 Chilisin Electronics (Suzhou) Co., Ltd. No.143,Song Shan Rd., Suzhou New District, Suzhou,China Postal Code:215129 TEL:+86-512-6841-2350 FAX:+86-512-6841-2356 E-mail : suzhou@chilisin.com.tw</p>
---	---

DRAWN BY 江鳳玉 linda.j	CHECKED BY 趙燕玲 annie	APPROVED BY 張鈺雯 chang.yuwen
--------------------------------	--------------------------------	---------------------------------------

NLC252018T Series Specification

1 Scope: This specification applies to Wire Wound Ferrite Chip Inductors

2 Part Numbering: Product Identification

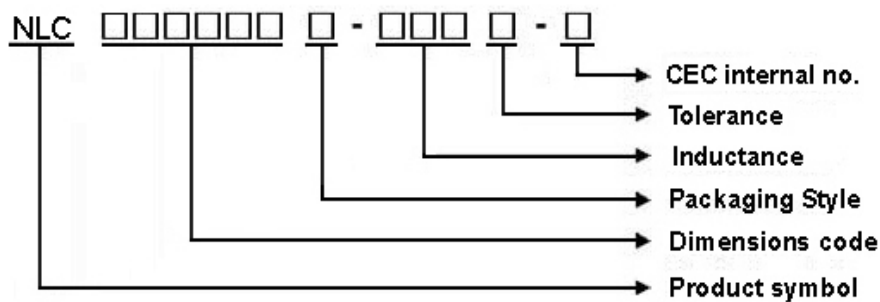

3 Rating:

Operating Temperature: $-25^{\circ}\text{C} \sim 105^{\circ}\text{C}$ (Including self - temperature rise)

Storage Temperature: Under 25°C , Humidity < 75% RH

4 Marking:

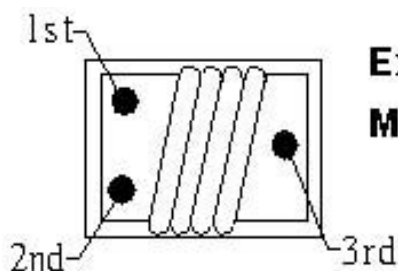

Ex: NLC252018T-100K-N

Marking: 1st → Brown

2nd → Black

3rd → Orange

5 Standard Testing Condition

	Unless otherwise specified	In case of doubt
Temperature	Ordinary Temperature(15 to 35°C)	20±2°C
Humidity	Ordinary Humidity(25 to 85% RH)	60 to 70 % RH

NLC252018T Series Specification

6 Configuration and Dimensions:

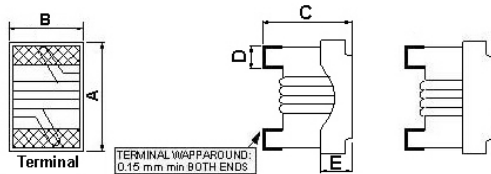

Dimensions in mm					
TYPE	A	B	C	D	E
NLC252018	2.92 ⁺⁰	2.5 ⁺⁰	2.2 ⁺⁰	0.51	0.51

7 ELECTRICAL CHARACTERISTICS :

Part No.	Inductance (uH)	L,Q Test Freq. (MHZ)	Q Min.	SRF (MHZ)Min.	RDC (Ω)Max.	IDC (mA)	Tolerance (±%)	Color Code		
								1st	2nd	3rd
NLC252018T-1R0□-N	1	7.96	25	300	0.34	1500	5,10	BRN	BLK	RED
NLC252018T-1R2□-N	1.2	7.96	25	280	0.4	1400	5,10	BRN	RED	RED
NLC252018T-1R5□-N	1.5	7.96	25	270	0.42	1400	5,10	BRN	GRN	RED
NLC252018T-1R8□-N	1.8	7.96	25	150	0.45	1200	5,10	BRN	GRY	RED
NLC252018T-2R2□-N	2.2	7.96	25	140	0.5	1200	5,10	RED	RED	RED
NLC252018T-3R3□-N	3.3	7.96	25	95	0.65	1000	5,10	ORN	ORN	RED
NLC252018T-4R7□-N	4.7	7.96	25	90	0.8	800	5,10	YEL	VIO	RED
NLC252018T-6R8□-N	6.8	7.96	25	68	1	730	5,10	BLU	GRY	RED
NLC252018T-100□-N	10	2.52	20	45	1.5	700	5,10	BRN	BLK	ORN
NLC252018T-150□-N	15	2.52	20	40	2.2	500	5,10	BRN	GRN	ORN
NLC252018T-220□-N	22	2.52	20	25	2.7	470	5,10	RED	RED	ORN
NLC252018T-330□-N	33	2.52	20	25	4	400	5,10	ORN	ORN	ORN
NLC252018T-390□-N	39	2.52	16	20	7	320	5,10	ORN	WHT	ORN
NLC252018T-470□-N	47	2.52	16	20	8	300	5,10	YEL	VIO	ORN

NOTE: □-tolerance J=±5% / K=±10% M=±20%

1. Operating temperature range – 25°C ~ 105°C (Including self - temperature rise)

2. IDC: Applied the current to coils, the inductance shall be less than 10% initial value.

"-N" FOR COMPLETELY LEAD FREE TYPE (INCLUDING FERRITE BODY & SOLDER)

NLC252018T Series Specification

8 NLC252018T Series

8.1 Construction:

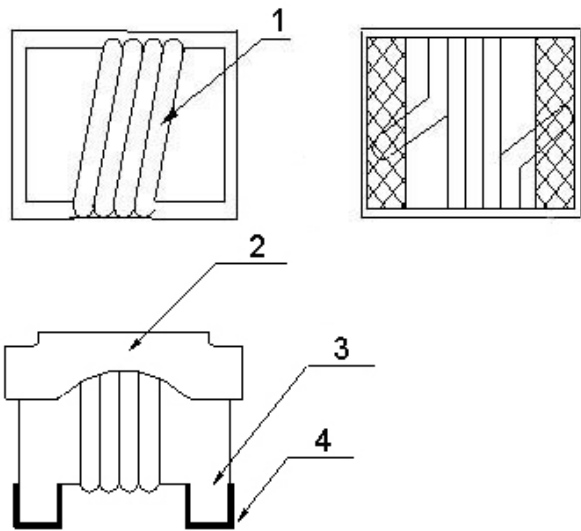

8.2 Material List:

ITEM	PART	DESCRIPTION	SUPPLIES
1	WIRE	Grade 180	ELEKTRISOLA
2	EPOXY	UV GLUE	PROVONCE
3	CORE	FERRITE	CHILISIN
4	TERMINAL	Ag/Ni/Sn	



NLC252018T Series Specification

9 Reliability Of Ferrite Wire Wound Chip Inductor/FERRITE SERIES

1-1.Environmental Performance

No	Item	Specification	Test Method																		
1-1-1	Temperature Cycle	Appearance: No Damage Inductance: within $\pm 10\%$ of initial value Q change: within $\pm 30\%$ of initial value	<table border="1"> <tr> <th colspan="3">One cycle:</th> </tr> <tr> <th>Step</th> <th>Temperature (°C)</th> <th>Time (min)</th> </tr> <tr> <td>1</td> <td>-25\pm3</td> <td>30</td> </tr> <tr> <td>2</td> <td>25\pm2</td> <td>3</td> </tr> <tr> <td>3</td> <td>105\pm3</td> <td>30</td> </tr> <tr> <td>4</td> <td>25\pm2</td> <td>3</td> </tr> </table>	One cycle:			Step	Temperature (°C)	Time (min)	1	-25 \pm 3	30	2	25 \pm 2	3	3	105 \pm 3	30	4	25 \pm 2	3
One cycle:																					
Step	Temperature (°C)	Time (min)																			
1	-25 \pm 3	30																			
2	25 \pm 2	3																			
3	105 \pm 3	30																			
4	25 \pm 2	3																			
1-1-2	Humidity Resistance	There should be no evidence of short or open circle	Total: 5 cycles Measured After Exposure in The Room Condition For 1hrs Temperature: 40 \pm 2°C Relative Humidity: 90 ~ 95% Time: 100hrs Measured After Exposure In The Room Condition For 1hrs																		
1-1-3	High Temperature Resistance		Temperature: 85 \pm 3°C Time: 50Hrs Measured After Exposure In The Room Condition For 1Hrs																		
1-1-4	Low Temperature Resistance		Temperature: -25 \pm 3°C Time: 50Hrs Measured After Exposure In The Room Condition For 1Hrs																		
1-1-5	High Temperature Load Life		Temperature: 85 \pm 3°C Load: Allowed DC Current Time: 1000Hrs																		
1-1-6	Humidity Load Life		Temperature: 40 \pm 2°C Relative Humidity: 90~95% Load: Allowed DC Current Time: 1000Hrs																		

1-2.Mechanical Performance

No	Item	Specification	Test Method
1-2-1	Resistance TO Soldering Heat	Appearance: No Damage	<ol style="list-style-type: none"> The device should be reflow soldered on PCB (peak 260°C \pm 5°C for 10 seconds) Solder Composition: Sn/Ag3.0/Cu0.5 Test time: 6 minutes
1-2-2	Solder ability	The electrodes shall be at least 95% covered with new solder coating	<ol style="list-style-type: none"> Pre-Heating: 150°C, 1min. Solder Composition: Sn/Ag3.0/Cu0.5 Solder Temperature: 245\pm5°C. Immersion Time: 4\pm1 sec.
1-2-3	Component Adhesion (Push Test)	2 Lbs. For NLC252018 4 Lbs. For NLC322522	The device should be reflow soldered (245 \pm 5°C For 10 seconds) to a tinned copper substrate. A force gauge should be applied to the side of the component. The device must withstand a minimum force of 1or2or4 pounds without a failure of the termination attached to component

NLC252018T Series Specification

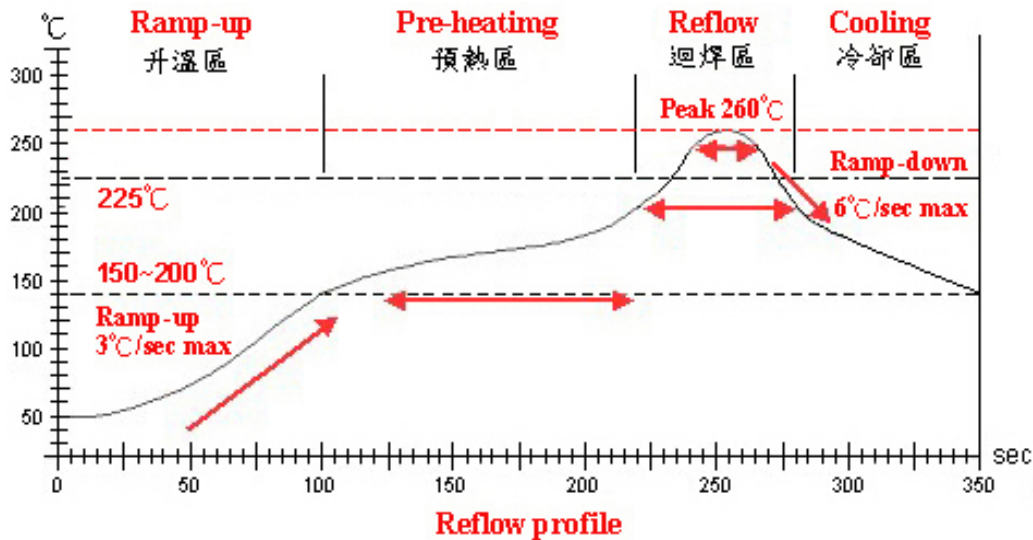

Lead-Free(LF) 標準溫度分析範圍

Refer to J-STD-020C

管制項目 Item.	升温區 Ramp-up	預熱區 Pre-heating	迴焊區 Reflow	Peak Temp	冷卻區 Cooling
溫度範圍 Temp.scope	R.T. ~ 150°C	150°C ~ 200°C	225°C	260±5°C	Peak Temp. ~ 150°C
實際時間 Time result	—	60 ~ 180 sec	20 ~ 60sec	5 ~ 10 sec	—

NOTE :

1. Re-flow possible times : within 2 times
2. Nitrogen adopted is recommended while in re-flow



NLC252018T Series Specification

0603/0805/201614 Series

Because of their small size, these parts are marked with a single color dot. The inductance value represented by the dot is shown on the data page for each series.

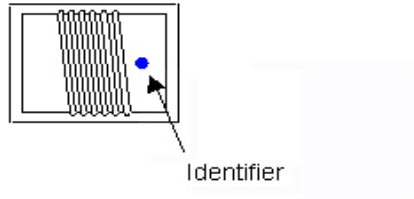

1008/1206/252018/322522 Series

These parts are marked with 3 color dots. The table at right side shows the significance of each color.

Dots 1 and 2 indicate the inductance in nanoHenries.

Dot 3 indicates the number of zeroes to be added.

0=Black	5=Green
1=Brown	6=Blue
2=Red	7=Violet
3=Orange	8=Gray
4=Yellow	9=White

Examples :

- Blue, Gray, Red = 6800 nH
- Red, Red, Brown = 220 nH
- Yellow, Violet, Black = 47 nH

NLC252018T Series Specification

11 PACKAGING

11.1 Packaging -Cover tape

The force for tearing off cover tape is 10 to 100 grams in the arrow direction.

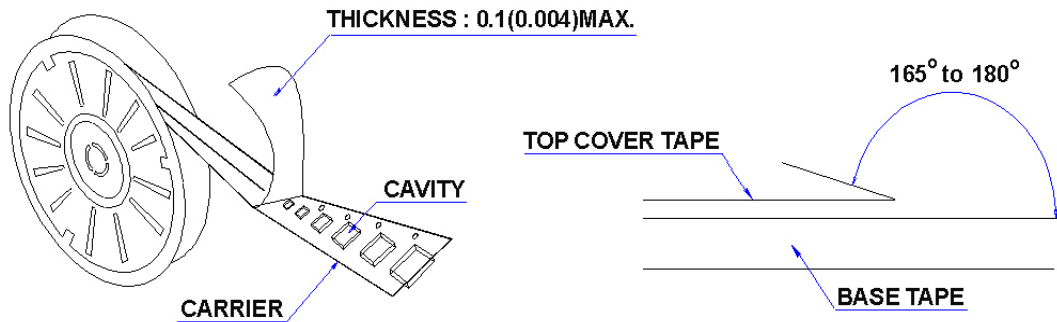

11.2 Packaging Quantity

TYPE	BULK	PCS/REEL
NLC252018	✓	2000
NLC322522	✓	2000

11.3 Reel Dimensions

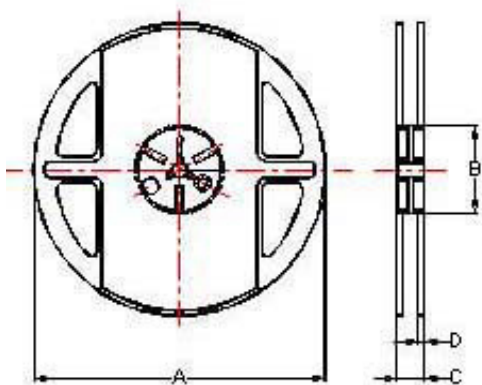

Reel Dimensions : m/m

TYPE	A	B	C	D
NLC252018	178	60	12	1.5
NLC322522	178	60	16	1.4

NLC252018T Series Specification

11 PACKAGING

11.4 Tape Dimensions in mm

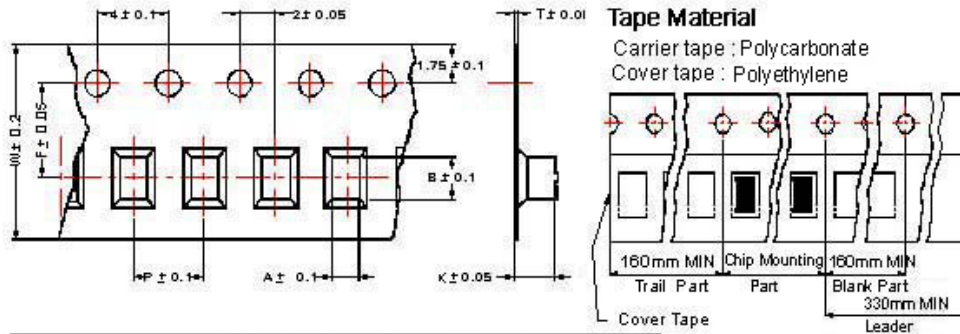

TYPE	A	B	T	W	P	F	K
NLC252018	2.40	2.93	0.26	8	4	3.5	2.25
NLC322522	2.85	3.58	0.25	12	4	5.5	2.85

12 Recommended Pattern

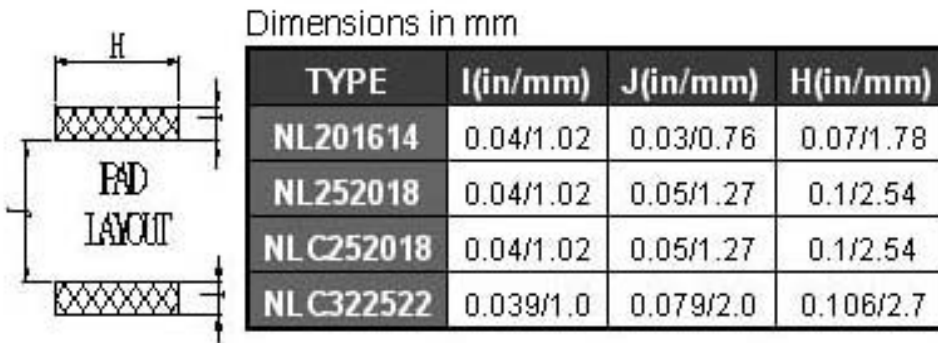

13 Note:

1. Please make sure that your product is has been evaluated and confirmed against your specifications when our product is mounted to your product.
2. Do not knock nor drop.
3. All the items and parameters in this product specification have been prescribed on the premise that our product is used for the purpose, under the condition and in the environment agreed upon between you and us. You are requested not to use our product deviating from such agreement.
4. Please keep the distance between transformer/coil and other components (refer to the standard IEC 950)



NLC252018T Series Specification

14 Curve:

