



ISO9001 & ISO14001 & TS16949 **CHILISIN ELECTRONICS CORP.**

**Lead-Free & RoHs Compliance!!**

## SPECIFICATION FOR APPROVAL

**CUSTOMER :** \_\_\_\_\_

**CUSTOMER P/N :** \_\_\_\_\_

**OUR DWG No :** \_\_\_\_\_

**QUANTITY :** 0 Pcs. **DATE :** 2013/07/12

**ITEM :** CM0603-SERIES

<b>SPECIFICATION ACCEPTED BY:</b>	
<b>COMPONENT ENGINEER</b>	
<b>ELECTRICAL ENGINEER</b>	
<b>MECHANICAL ENGINEER</b>	
<b>APPROVED</b>	
<b>REJECTED</b>	

<p><b>奇力新電子股份有限公司</b>          CHILISIN ELECTRONICS CORP.          NO.29,LANE 301,TEHHSIN ROAD,HUKOU,          HSINCHU,TAIWAN,303,          REPUBLIC OF CHINA          TEL : (03) 599-2646          FAX : (03) 599-9176          E-mail : Sales@chilisin.com.tw          http : //www.chilisin.com.tw</p> <p><b>台北營業處</b>  <b>Taipei Office</b>          1F., No.2, Aly. 1, Ln. 235, Baoqiao Rd.,          Xindian Dist., New Taipei City 231, Taiwan          TEL : +886-2-6629-5588~9          FAX : +886-2-6629-0088          E-mail : Sales@chilisin.com.tw</p>	<p><b>東莞奇力新電子有限公司</b>          Chilisin Electronics (Dongguan) Co., Ltd.          No. 78, Puxing Rd., Yuliangwei Administration Area,          Qingxi Town, Dongguan City, Guangdong,China          TEL : +86-769-8773-0251~3          FAX : +86-769-8773-0232          E-mail : cect@chilisin.com.tw</p> <p><b>奇力新電子(蘇州)有限公司</b>          Chilisin Electronics (Suzhou) Co., Ltd.          No.143,Song Shan Rd., Suzhou New District,          Suzhou,China          Postal Code:215129          TEL:+86-512-6841-2350          FAX:+86-512-6841-2356          E-mail : suzhou@chilisin.com.tw</p>
---	---

  

<b>DRAWN BY</b> 林明玉 gloria.lin	<b>CHECKED BY</b> 溫美玲 ling	<b>APPROVED BY</b> 詹嘉皓 allen.chan
-----------------------------------	-------------------------------	--------------------------------------

## CM0603 Series Specification

**1** Scope: This specification applies to Wire Wound Ceramic Chip Inductors

**2** Part Numbering: Product Identification

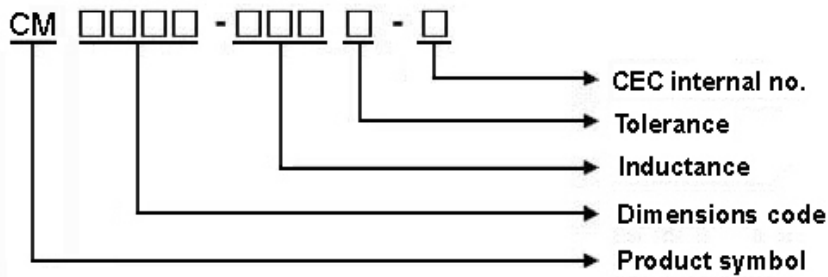

**3** Rating:

Operating Temperature:  $-40^{\circ}\text{C} \sim 125^{\circ}\text{C}$  (Including self - temperature rise)

Storage Temperature:  $20^{\circ}\text{C} \sim 25^{\circ}\text{C}$  R.H. 65% (For Reference)

**4** Marking:



**5** Standard Testing Condition

	Unless otherwise specified	In case of doubt
Temperature	Ordinary Temperature(15 to 35°C)	20±2°C
Humidity	Ordinary Humidity(25 to 85% RH)	60 to 70 % RH

# CM0603 Series Specification

## 6 Configuration and Dimensions:

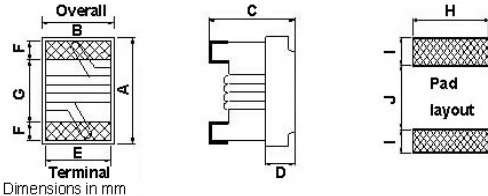

Dimensions in mm

TYPE	A	B	C	D	E	F	G	H	I	J
CM0603	1.6 <sup>+0.2</sup> <sub>-0.1</sub>	1.02±0.1	0.82 <sup>+0.2</sup> <sub>-0.1</sub>	0.35	0.70	0.30	0.95	1.02	0.64	0.64

## 7 ELECTRICAL CHARACTERISTICS :

Part No.	Inductance (nH)	L/Q Test Freq. (MHz)	Q Min.	SRF (GHz)Min.	RDC (Ω)Max.	I <sub>rms</sub> (mA)Max.	Tolerance
CM0603-2N2□-N	2.2	100/250	16	6	0.049	700	D
CM0603-3N6□-N	3.6	100/250	25	6	0.059	850	C,D
CM0603-3N9□-N	3.9	100/250	35	6	0.059	850	C,D
CM0603-4N3□-N	4.3	100/250	35	6	0.059	850	C,D
CM0603-4N7□-N	4.7	100/250	35	6	0.059	850	D
CM0603-5N6□-N	5.6	100/250	35	6	0.082	750	C,D
CM0603-6N2□-N	6.2	100/250	35	6	0.082	750	C,D
CM0603-6N8□-N	6.8	100/250	35	6	0.082	750	C,D
CM0603-7N5□-N	7.5	100/250	35	6	0.082	750	D
CM0603-8N2□-N	8.2	100/250	35	6	0.11	650	D
CM0603-8N7□-N	8.7	100/250	35	6	0.11	650	D
CM0603-9N1□-N	9.1	100/250	35	6	0.11	650	D
CM0603-9N5□-N	9.5	100/250	35	6	0.11	650	D
CM0603-10N□-N	10	100/250	35	6	0.11	650	G,J
CM0603-11N□-N	11	100/250	35	6	0.11	650	G,J
CM0603-12N□-N	12	100/250	35	6	0.13	600	G,J
CM0603-13N□-N	13	100/250	35	6	0.13	600	G,J
CM0603-15N□-N	15	100/250	40	6	0.13	600	G,J
CM0603-16N□-N	16	100/250	40	5.5	0.16	550	G,J
CM0603-18N□-N	18	100/250	40	5.5	0.16	550	G,J
CM0603-20N□-N	20	100/250	40	4.9	0.16	550	G,J
CM0603-22N□-N	22	100/250	40	4.6	0.17	500	G,J
CM0603-24N□-N	24	100/250	40	3.8	0.21	500	G,J
CM0603-27N□-N	27	100/250	40	3.7	0.21	440	G,J
CM0603-30N□-N	30	100/250	40	3.3	0.23	420	G,J

**NOTE:** □-tolerance C=±0.2nH / D=±0.5nH / J=±5% / G=±2%

1. Operating temperature range – 4 0 °C ~ 1 2 5 °C (Including self - temperature rise)

 2. I<sub>rms</sub> for 15 °C rise above 25 °C ambient.

3. L/Q Test OSC @200mV.

4. Inductance would be correct Chilisin standard piece.

"-N" FOR COMPLETELY LEAD FREE TYPE(INCLUDING FERRITE BODY &amp; SOLDER)



## CM0603 Series Specification

Part No.	Inductance (nH)	L/Q Test Freq. (MHz)	Q Min.	SRF (GHz)Min.	RDC ( $\Omega$ )Max.	Irms (mA)Max.	Tolerance
CM0603-33N□-N	33	100/250	40	3.2	0.23	420	G,J
CM0603-36N□-N	36	100/250	40	2.9	0.26	400	G,J
CM0603-39N□-N	39	100/250	40	2.8	0.26	400	G,J
CM0603-43N□-N	43	100/200	40	2.7	0.29	380	G,J
CM0603-47N□-N	47	100/200	38	2.6	0.29	380	G,J
CM0603-51N□-N	51	100/200	38	2.5	0.33	370	G,J
CM0603-56N□-N	56	100/200	38	2.4	0.35	360	G,J
CM0603-62N□-N	62	100/200	38	2.3	0.51	280	G,J
CM0603-68N□-N	68	100/200	38	2.2	0.38	340	G,J
CM0603-72N□-N	72	100/150	34	2.1	0.56	270	G,J
CM0603-75N□-N	75	100/150	34	2.05	0.56	270	G,J
CM0603-82N□-N	82	100/150	34	2	0.6	250	G,J
CM0603-91N□-N	91	100/150	34	1.9	0.64	230	G,J
CM0603-R10□-N	100	100/150	34	1.8	0.68	220	G,J
CM0603-R11□-N	110	100/150	32	1.7	1.2	200	G,J
CM0603-R12□-N	120	100/150	32	1.6	1.3	180	G,J
CM0603-R13□-N	130	100/150	32	1.45	1.4	170	G,J
CM0603-R15□-N	150	100/150	32	1.4	1.5	160	G,J
CM0603-R16□-N	160	100/150	32	1.35	2.1	150	G,J
CM0603-R18□-N	180	100/100	25	1.3	2.2	140	G,J
CM0603-R20□-N	200	100/100	25	1.25	2.4	120	G,J
CM0603-R22□-N	220	100/100	25	1.2	2.5	120	G,J
CM0603-R27□-N	270	100/100	30	0.96	3.4	110	G,J
CM0603-R33□-N	330	100/100	30	0.8	5.5	85	G,J
CM0603-R39□-N	390	100/100	30	0.8	6.2	80	G,J
CM0603-R47□-N	470	100/100	30	0.7	7	75	G,J

## CM0603 Series Specification

### 8 CM0603 Series

#### 8.1 Construction:

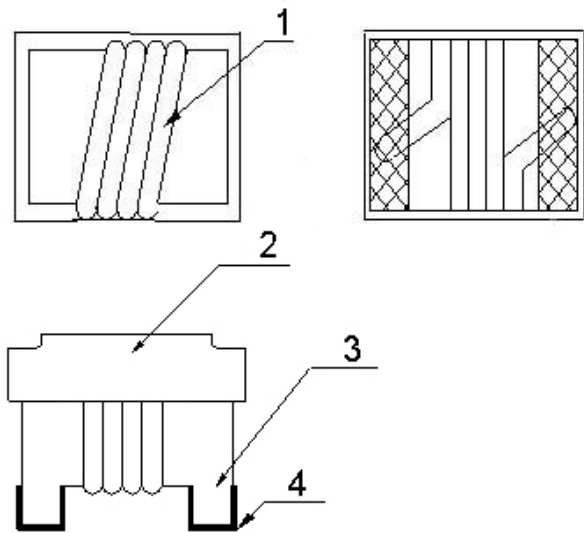

#### 8.2 Material List:

ITEM	PART	DESCRIPTION	SUPPLIES
1	WIRE	Grade 180	ELEKTRISOLA
2	EPOXY	UV GLUE	PROVONCE
3	CORE	CERAMIC	CHILISIN
4	TERMINAL	Ag/Ni/Sn	



# CM0603 Series Specification

## 9 Reliability Of Ceramic Wire Wound Chip Inductor/CERAMIC SERIES

### 1-1.Environmental Performance

No	Item	Specification	Test Method		
1-1-1	Temperature Cycle	Appearance: No Damage Inductance: within $\pm 10\%$ of initial value Q change: within $\pm 30\%$ of initial value	One cycle:		
			Step	Temperature ( $^{\circ}\text{C}$ )	Time (min)
			1	-40 $\pm$ 3	30
			2	25 $\pm$ 2	15
			3	125 $\pm$ 3	30
4	25 $\pm$ 2	15			
			Total: 5 cycles Measured After Exposure in The Room Condition For 1hrs		
1-1-2	Humidity Resistance		Temperature: 40 $\pm$ 2 $^{\circ}\text{C}$ Relative Humidity: 90 ~ 95% Time: 100hrs Measured After Exposure In The Room Condition For 1hrs		
1-1-3	High Temperature Resistance		Temperature: 125 $\pm$ 3 $^{\circ}\text{C}$ Time: 50Hrs Measured After Exposure In The Room Condition For 1Hrs		
1-1-4	Low Temperature Resistance		Temperature: -40 $\pm$ 3 $^{\circ}\text{C}$ Time: 50Hrs Measured After Exposure In The Room Condition For 1Hrs		
1-1-5	High Temperature Load Life	There should be no evidence of short or open circle	Temperature: 85 $\pm$ 3 $^{\circ}\text{C}$ Load: Allowed DC Current Time: 1000Hrs		
1-1-6	Humidity Load Life		Temperature: 40 $\pm$ 2 $^{\circ}\text{C}$ Relative Humidity: 90~95% Load: Allowed DC Current Time: 1000Hrs		

### 1-2.Mechanical Performance

No	Item	Specification	Test Method
1-2-1	Vibration Test (Low Frequency)	1.Appearance: No Damage 2.Inductance: within $\pm 10\%$ of initial value 3.Q change: within $\pm 30\%$ of initial value	1. Test device shall be soldered on the substrate. 2. Oscillation frequency: 10 to 55 to 10Hz for 1min. 3. Amplitude: 1.5mm 4. Time: 2hrs for each axis(X, Y & Z), total 6hrs
1-2-2	Resistance TO Soldering Heat	Appearance: No Damage	1. The device should be reflow soldered on PCB (peak 260 $^{\circ}\text{C}$ $\pm$ 5 $^{\circ}\text{C}$ for 10 seconds) 2. Solder Composition: Sn/Ag3.0/Cu0.5 3. Test time: 6 minutes
1-2-3	Solder ability	The electrodes shall be at least 95% covered with new solder coating	1. Pre-Heating: 150 $^{\circ}\text{C}$ , 1min. 2. Solder Composition: Sn/Ag3.0/Cu0.5 3. Solder Temperature: 245 $\pm$ 5 $^{\circ}\text{C}$ . 4. Immersion Time: 4 $\pm$ 1 sec.
1-2-4	Component Adhesion (Push Test)	1 Lbs. For 0402 2 Lbs. For 0603 4 Lbs. For The Rest	The device should be reflow soldered (245 $\pm$ 5 $^{\circ}\text{C}$ For 10 seconds) to a tinned copper substrate. A force gauge should be applied to the side of the component. The device must withstand a minimum force of 2 or 4 pounds without a failure of the termination attached to component

# CM0603 Series Specification

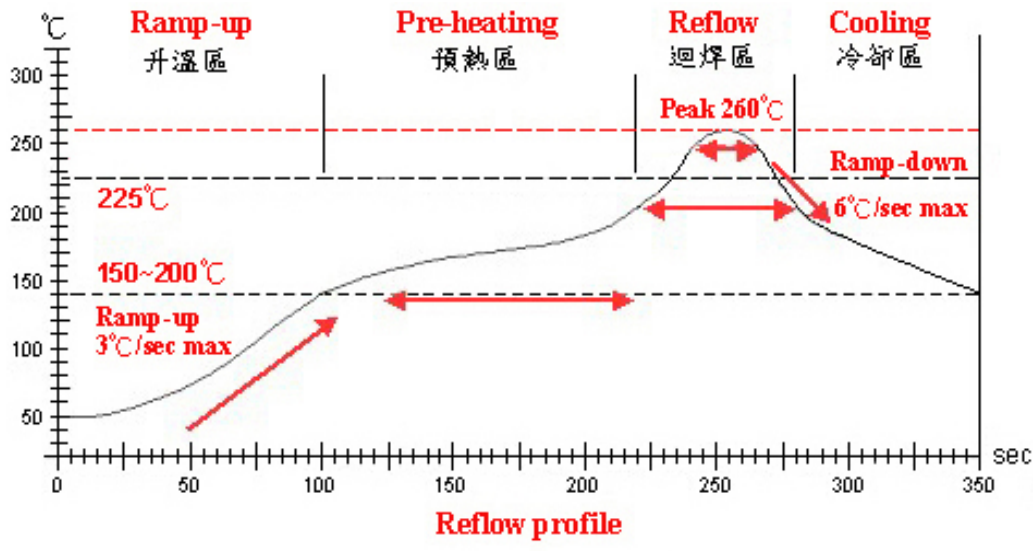

Lead-Free(LF) 標準溫度分析範圍

Refer to J-STD-020C

管制項目 Item.	升溫區 Ramp-up	預熱區 Pre-heating	迴焊區 Reflow	Peak Temp	冷卻區 Cooling
溫度範圍 Temp.scope	R.T. ~ 150°C	150°C ~ 200°C	225°C	260±5°C	Peak Temp. ~ 150°C
實際時間 Time result	—	60 ~ 180 sec	20 ~ 60 sec	5 ~ 10 sec	—

NOTE :

1. Re-flow possible times : within 2 times
2. Nitrogen adopted is recommended while in re-flow

# CM0603 Series Specification

## 11 PACKAGING

### 11.1 Packaging -Cover tape

The force for tearing off cover tape is 10 to 100 grams in the arrow direction.

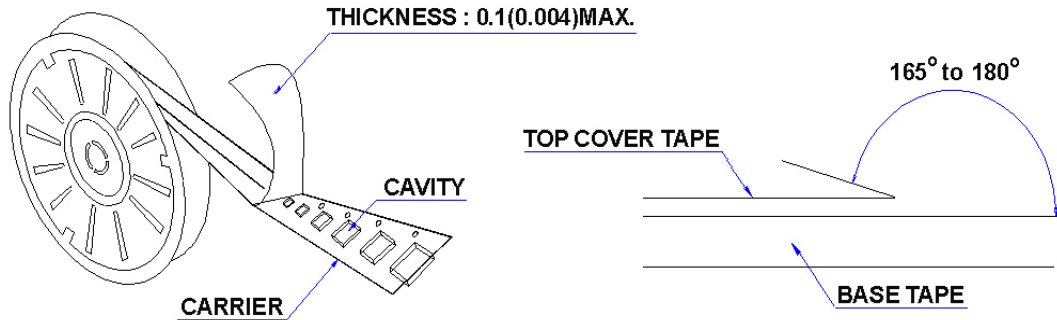

### 11.2 Packaging Quantity

TYPE	BULK	PCS/REEL
CM0302	✓	4000
CM0402	✓	4000
CM0603	✓	4000

### 11.3 Reel Dimensions

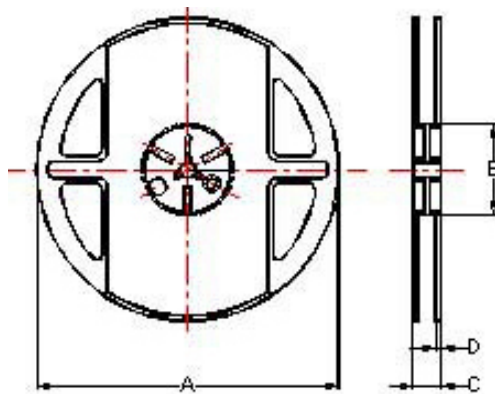

Reel Dimensions : m/m

TYPE	A	B	C	D
CM0302	178	60	12	1.5
CM0402	178	60	12	1.5
CM0603	178	60	12	1.5



# CM0603 Series Specification

## 11 PACKAGING

### 11.4 Tape Dimensions in mm

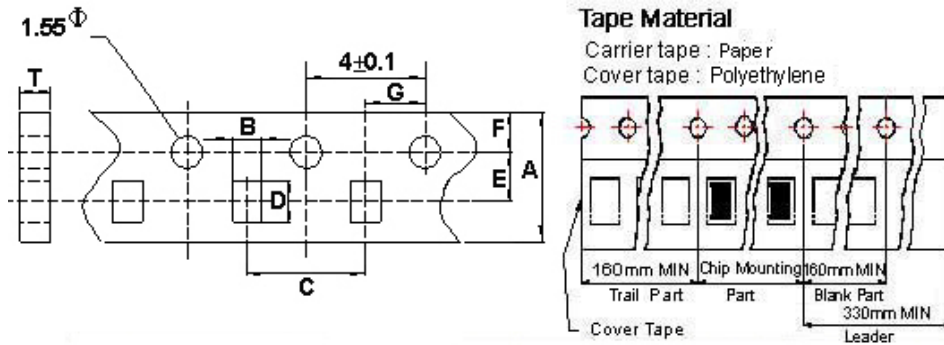

TYPE	A	B	C	D	E	F	G	T
CM0603	8.0	1.16	4	1.85	3.5	1.75	2	0.95

## 12 Recommended Pattern

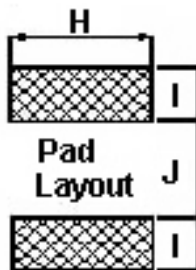

Dimensions in mm

TYPE	I(in/mm)	J(in/mm)	H(in/mm)
CM0302	0.009/0.25	0.013/0.35	0.020/0.53
CM0402	0.014/0.36	0.018/0.46	0.026/0.66
CM0603	0.025/0.64	0.025/0.64	0.04/1.02

## 13 Note:

1. Please make sure that your product is has been evaluated and confirmed against your specifications when our product is mounted to your product.
2. Do not knock nor drop.
3. All the items and parameters in this product specification have been prescribed on the premise that our product is used for the purpose, under the condition and in the environment agreed upon between you and us. You are requested not to use our product deviating from such agreement.
4. Please keep the distance between transformer/coil and other components (refer to the standard IEC 950)