



ISO9001 & ISO14001 & TS16949 **CHILISIN ELECTRONICS CORP.**

Lead-Free & RoHs Compliance!!

SPECIFICATION FOR APPROVAL

CUSTOMER : _____

CUSTOMER P/N : _____

OUR DWG No : _____

QUANTITY : 0 Pcs. **DATE :** 2013/03/07

ITEM : SCDS127T-SERIES

SPECIFICATION ACCEPTED BY:	
COMPONENT ENGINEER	
ELECTRICAL ENGINEER	
MECHANICAL ENGINEER	
APPROVED	
REJECTED	

<p>奇力新電子股份有限公司 CHILISIN ELECTRONICS CORP. NO.29,LANE 301,TEHHSIN ROAD,HUKOU, HSINCHU,TAIWAN,303, REPUBLIC OF CHINA TEL : (03) 599-2646 FAX : (03) 599-9176 E-mail : Sales@chilisin.com.tw http : //www.chilisin.com.tw</p> <p>台北營業處 Taipei Office 1F., No.2, Aly. 1, Ln. 235, Baoqiao Rd., Xindian Dist., New Taipei City 231, Taiwan TEL : +886-2-6629-5588~9 FAX : +886-2-6629-0088 E-mail : Sales@chilisin.com.tw</p>	<p>東莞奇力新電子有限公司 Chilisin Electronics (Dongguan) Co., Ltd. No. 78, Puxing Rd., Yuliangwei Administration Area, Qingxi Town, Dongguan City, Guangdong,China TEL : +86-769-8773-0251~3 FAX : +86-769-8773-0232 E-mail : cect@chilisin.com.tw</p> <p>奇力新電子(蘇州)有限公司 Chilisin Electronics (Suzhou) Co., Ltd. No.143,Song Shan Rd., Suzhou New District, Suzhou,China Postal Code:215129 TEL:+86-512-6841-2350 FAX:+86-512-6841-2356 E-mail : suzhou@chilisin.com.tw</p>
---	---

DRAWN BY 陳瑞揚 ryan.chen	CHECKED BY 張麗玲 ll.chang	APPROVED BY 陳瑞揚 ryan.chen
---	--	--

SCDS127T Series Specification

1 Scope: This specification applies to SMD POWER CHOKE

2 Part Numbering: Product Identification

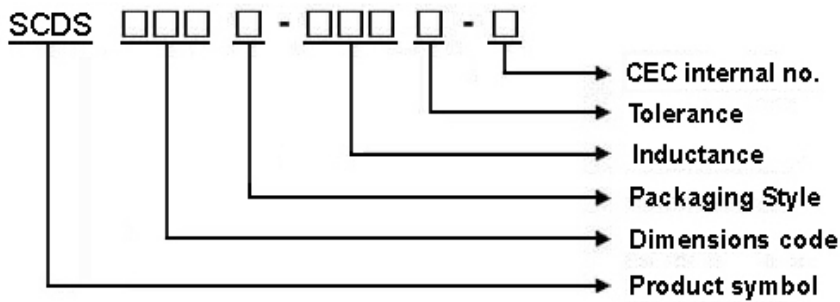

3 Rating:

Operating Temperature: $-40^{\circ}\text{C} \sim 105^{\circ}\text{C}$ (Including self - temperature rise)

Storage Temperature: Under 25°C , Humidity < 75% RH

4 Marking:



Ex:SCDS127T-100M-N

Marking:100

Marking color : Black

5 Standard Testing Condition

	Unless otherwise specified	In case of doubt
Temperature	Ordinary Temperature(15 to 35°C)	20±2°C
Humidity	Ordinary Humidity(25 to 85% RH)	60 to 70 % RH

SCDS127T Series Specification

6 Configuration and Dimensions:

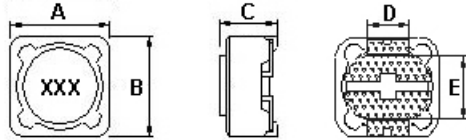

Dimensions in mm

TYPE	A	B	C	D	E
SCDS127	12.5 ⁺⁰	12.5 ⁺⁰	8.0 ⁺⁰	5	7.6

7 ELECTRICAL CHARACTERISTICS :

Part No.	Inductance (uH)	Test Freq.	RDC (Ω)Max.	Isat (A)	Tolerance	Marking
SCDS127T-1R2□-N	1.2	100 kHz, 1 V	0.007	9.8	N	1R2
SCDS127T-1R5□-N	1.5	100 kHz, 1 V	0.008	9.5	T	1R5
SCDS127T-2R2□-N	2.2	100 kHz, 1 V	0.0115	8	M, T, N	2R2
SCDS127T-2R4□-N	2.4	100 kHz, 1 V	0.0115	8	M, T, N	2R4
SCDS127T-3R3□-N	3.3	100 kHz, 1 V	0.0135	7.5	T, N	3R3
SCDS127T-3R5□-N	3.5	100 kHz, 1 V	0.0135	7.5	M, T, N	3R5
SCDS127T-4R7□-N	4.7	100 kHz, 1 V	0.0158	6.8	M, T	4R7
SCDS127T-6R1□-N	6.1	100 kHz, 1 V	0.0176	6.6	M, T, N	6R1
SCDS127T-6R8□-N	6.8	100 kHz, 1 V	0.02	6.2	M, T	6R8
SCDS127T-7R6□-N	7.6	100 kHz, 1 V	0.02	5.9	M, T	7R6
SCDS127T-100□-N	10	1 kHz, 1 V	0.0216	5.4	M	100
SCDS127T-120□-N	12	1 kHz, 1 V	0.0243	4.9	M	120
SCDS127T-150□-N	15	1 kHz, 1 V	0.027	4.5	M	150
SCDS127T-180□-N	18	1 kHz, 1 V	0.0392	3.9	M	180
SCDS127T-220□-N	22	1 kHz, 1 V	0.0432	3.6	M	220
SCDS127T-270□-N	27	1 kHz, 1 V	0.0459	3.4	M	270
SCDS127T-330□-N	33	1 kHz, 1 V	0.0648	3	M	330
SCDS127T-390□-N	39	1 kHz, 1 V	0.0729	2.75	M	390
SCDS127T-470□-N	47	1 kHz, 1 V	0.1	2.5	M	470
SCDS127T-560□-N	56	1 kHz, 1 V	0.11	2.35	M	560
SCDS127T-680□-N	68	1 kHz, 1 V	0.14	2.1	M	680
SCDS127T-820□-N	82	1 kHz, 1 V	0.16	1.95	M	820
SCDS127T-101□-N	100	1 kHz, 1 V	0.22	1.7	M	101
SCDS127T-121□-N	120	1 kHz, 1 V	0.25	1.6	M	121
SCDS127T-151□-N	150	1 kHz, 1 V	0.28	1.42	M	151

NOTE: □-tolerance M=±20% / T=±30% / N=+40% -20%

1. Operating temperature range – 4 0 °C ~ 1 0 5 °C (Including self - temperature rise)

2. Isat: Inductance drop = 35% typ.

"-N" FOR COMPLETELY LEAD FREE TYPE (INCLUDING FERRITE BODY & SOLDER)



ISO9001 & ISO14001 & TS16949 **CHILISIN ELECTRONICS CORP.**

SCDS127T Series Specification

Part No.	Inductance (μ H)	Test Freq.	RDC (Ω)Max.	Isat (A)	Tolerance	Marking
SCDS127T-181□-N	180	1 kHz, 1 V	0.35	1.3	M	181
SCDS127T-221□-N	220	1 kHz, 1 V	0.39	1.16	M	221
SCDS127T-271□-N	270	1 kHz, 1 V	0.56	1.06	M	271
SCDS127T-331□-N	330	1 kHz, 1 V	0.64	0.95	M	331
SCDS127T-391□-N	390	1 kHz, 1 V	0.7	0.88	M	391
SCDS127T-471□-N	470	1 kHz, 1 V	0.98	0.79	M	471
SCDS127T-561□-N	560	1 kHz, 1 V	1.07	0.73	M	561
SCDS127T-681□-N	680	1 kHz, 1 V	1.46	0.67	M	681
SCDS127T-821□-N	820	1 kHz, 1 V	1.64	0.6	M	821
SCDS127T-102□-N	1000	1 kHz, 1 V	1.82	0.55	M	102

SCDS127T Series Specification

8 SCDS127T Series

8.1 Construction:

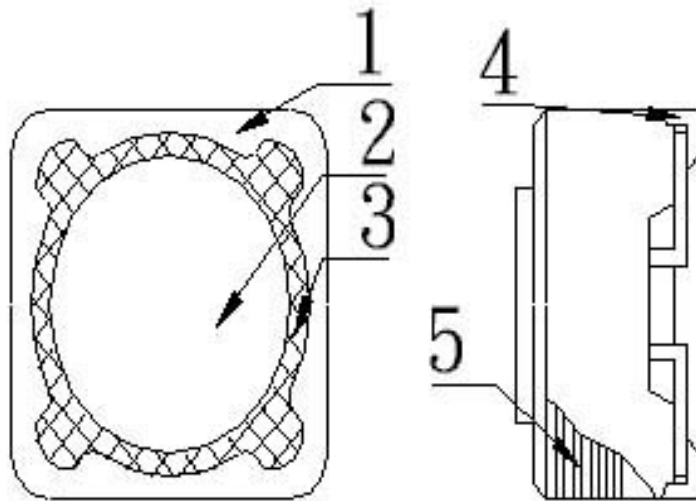

8.2 Material List:

ITEM	PART	DESCRIPTION	SUPPLIES
1	CORE	FERRITE	CHILISIN
2	CORE	FERRITE	CHILISIN
3	EPOXY		WELLS
4	TERMINAL	TERMINAL COPPER	CHILISIN
5	WIRE	MAGNET WIRE	



SCDS127T Series Specification

9 Reliability Of Ferrite Wire Wound Power Inductor

1-1.Mechanical Performance

No	Item	Specification	Test Method
1-1-1	Vibration	Appearance: No damage Inductance: within $\pm 10\%$ of initial value	Test device shall be soldered on the substrate Oscillation Frequency: 10 to 55 to 10Hz for 1min Amplitude: 1.5mm Time: 2hrs for each axis (X, Y & Z), total 6hrs
1-1-2	Resistance to Soldering Heat	Appearance: No damage	Pre-heating: 150°C, 1min Solder Composition: Sn/Ag3.0/Cu0.5 Solder Temperature: 260 \pm 5°C Immersion Time: 10 \pm 1sec
1-1-3	Solder ability	The electrodes shall be at least 95% covered with new solder coating	Pre-heating: 150°C, 1min Solder Composition: Sn/Ag3.0/Cu0.5 Solder Temperature: 245 \pm 5°C Immersion Time: 4 \pm 1sec
1-1-4	Resistance to solvent	There must be no change in appearance or obliteration of marking.	Inductors must withstand 6 minutes of alcohol or water.

1-2.Environmental Performance

No	Item	Specification	Test Method															
1-2-1	Temperature Shock	Appearance: No damage Inductance: within $\pm 10\%$ of initial value	10 cycles (Air to Air) 1 cycles shall consist of: 30 minutes exposure to -55 °C 30 minutes exposure to 125 °C 15 seconds maximum transition between temperatures															
1-2-2	Temperature Cycle		One cycle: <table border="1" style="width: 100%; border-collapse: collapse;"> <thead> <tr> <th>Step</th> <th>Temperature (°C)</th> <th>Time (min)</th> </tr> </thead> <tbody> <tr> <td>1</td> <td>-40\pm3</td> <td>30</td> </tr> <tr> <td>2</td> <td>25\pm2</td> <td>3</td> </tr> <tr> <td>3</td> <td>105\pm3</td> <td>30</td> </tr> <tr> <td>4</td> <td>25\pm2</td> <td>3</td> </tr> </tbody> </table>	Step	Temperature (°C)	Time (min)	1	-40 \pm 3	30	2	25 \pm 2	3	3	105 \pm 3	30	4	25 \pm 2	3
Step	Temperature (°C)		Time (min)															
1	-40 \pm 3		30															
2	25 \pm 2		3															
3	105 \pm 3	30																
4	25 \pm 2	3																
1-2-3	Humidity Resistance	Temperature: 40 \pm 2°C Relative Humidity: 90 ~ 95% Time: 1000hrs Measured after exposure in the room condition for 24hrs																
1-2-4	Heat Life	Temperature: 85 \pm 3°C Relative Humidity: 20% Applied Current: Rated Current Time: 1000hrs Measured after exposure in the room condition for 24hrs																
1-2-5	Cold Resistance	Temperature: -40 \pm 3°C Relative Humidity: 0% Time: 1000hrs Measured after exposure in the room condition for 24hrs																

SCDS127T Series Specification

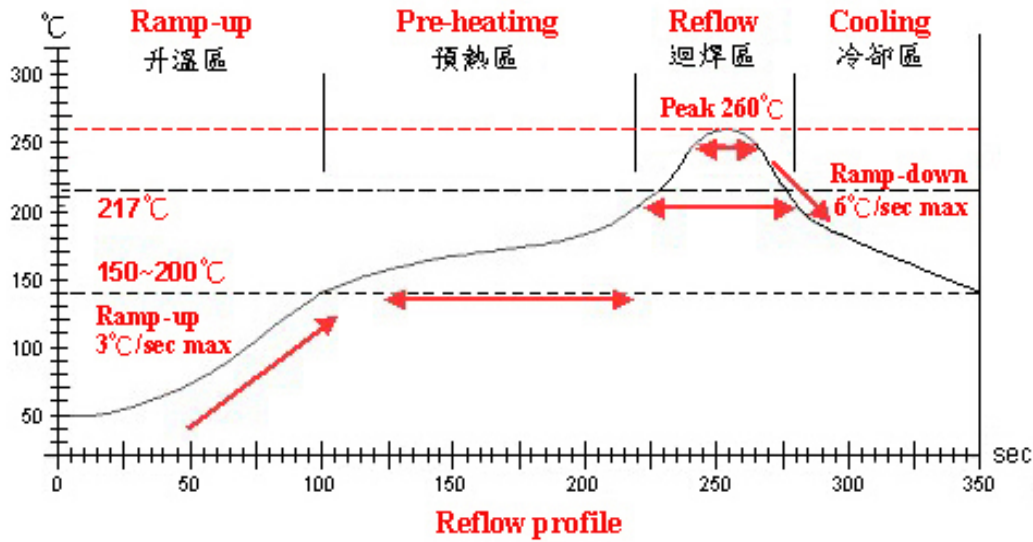

Lead-Free(LF) 標準溫度分析範圍

Refer to J-STD-020C

管制項目 Item.	升温區 Ramp-up	預熱區 Pre-heating	迴焊區 Reflow	Peak Temp	冷卻區 Cooling
溫度範圍 Temp.scope	R.T. ~ 150°C	150°C ~ 200°C	217°C	260±5°C	Peak Temp. ~ 150°C
標準時間 Time spec.	—	60 ~ 180 sec	60 ~ 150sec	20 ~ 40 sec	—
實際時間 Time result	—	75 ~ 100 sec	90 ~ 120sec	20 ~ 35 sec	—

SCDS127T Series Specification

11 PACKAGING

11.1 Packaging -Cover tape

The force for tearing off cover tape is 10 to 130 grams in the arrow direction.

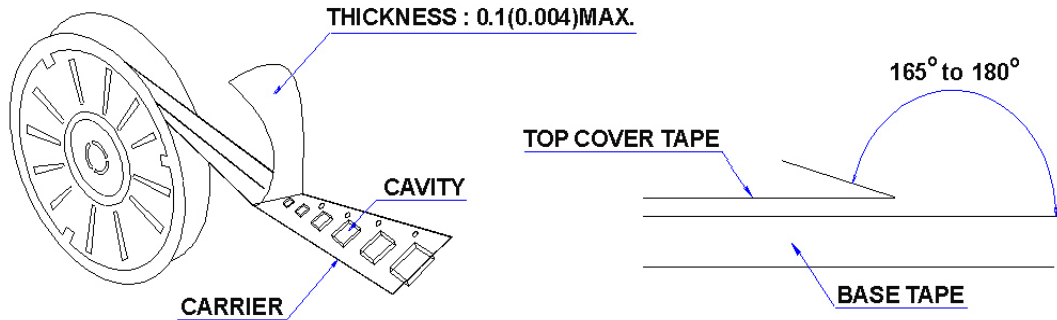

11.2 Packaging Quantity

TYPE	BULK	PCS/REEL
SCDS62	✓	1500
SCDS64	✓	1000
SCDS73	✓	1600
SCDS74	✓	1000
SCDS124	✓	500
SCDS125	✓	600
SCDS127	✓	500

11.3 Reel Dimensions

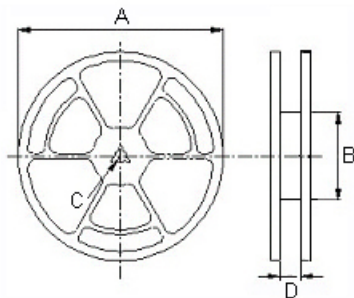

Reel Dimesions : m/m

TYPE	A	B	C	D
SCDS62	330	100	13	17.4
SCDS64	330	100	13	17.4
SCDS73	330	100	13	17.4
SCDS74	330	100	13	17.4
SCDS124	330	100	13	24.4
SCDS125	330	100	13	24.4
SCDS127	330	100	13	24.4

SCDS127T Series Specification

11 PACKAGING

11.4 Tape Dimensions in mm

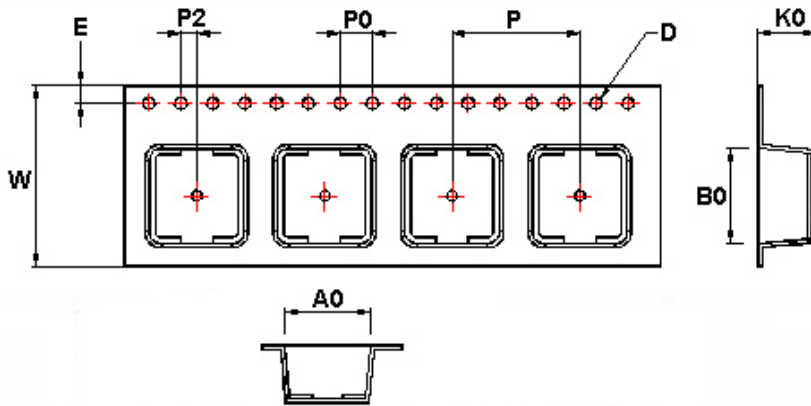

TYPE	A0	B0	K0	D	E	W	P	P0	P2
SCDS127	12.6	12.6	8.7	1.55	1.75	24	16	4	2

12 Recommended Pattern

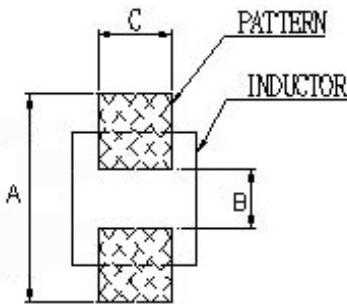

Dimensions in mm

TYPE	A(mm)	B(mm)	C(mm)
SCDS62	8.1	4	2.5
SCDS64	8.1	4	2.5
SCDS73	8.4	4.4	2.2
SCDS74	8.4	4.4	2.2
SCDS124	13	7.0	5.4
SCDS125	13	7.0	5.4
SCDS127	13	7.0	5.4

13 Note:

1. Please make sure that your product is has been evaluated and confirmed against your specifications when our product is mounted to your product.
2. Do not knock nor drop.
3. All the items and parameters in this product specification have been prescribed on the premise that our product is used for the purpose, under the condition and in the environment agreed upon between you and us. You are requested not to use our product deviating from such agreement.
4. Please keep the distance between transformer/coil and other components (refer to the standard IEC 950)