



ISO9001 & ISO14001 & TS16949 **CHILISIN ELECTRONICS CORP.**

Lead-Free & RoHs Compliance!!

SPECIFICATION FOR APPROVAL

CUSTOMER : _____

CUSTOMER P/N : _____

OUR DWG No : _____

QUANTITY : 0 Pcs. **DATE :** 2013/04/17

ITEM : SCDS105R-SERIES

SPECIFICATION ACCEPTED BY:	
COMPONENT ENGINEER	
ELECTRICAL ENGINEER	
MECHANICAL ENGINEER	
APPROVED	
REJECTED	

<p>奇力新電子股份有限公司 CHILISIN ELECTRONICS CORP. NO.29,LANE 301,TEHHSIN ROAD,HUKOU, HSINCHU,TAIWAN,303, REPUBLIC OF CHINA TEL : (03) 599-2646 FAX : (03) 599-9176 E-mail : Sales@chilisin.com.tw http : //www.chilisin.com.tw</p> <p>台北營業處 Taipei Office 1F., No.2, Aly. 1, Ln. 235, Baoqiao Rd., Xindian Dist., New Taipei City 231, Taiwan TEL : +886-2-6629-5588~9 FAX : +886-2-6629-0088 E-mail : Sales@chilisin.com.tw</p>	<p>東莞奇力新電子有限公司 Chilisin Electronics (Dongguan) Co., Ltd. No. 78, Puxing Rd., Yuliangwei Administration Area, Qingxi Town, Dongguan City, Guangdong,China TEL : +86-769-8773-0251~3 FAX : +86-769-8773-0232 E-mail : cect@chilisin.com.tw</p> <p>奇力新電子(蘇州)有限公司 Chilisin Electronics (Suzhou) Co., Ltd. No.143,Song Shan Rd., Suzhou New District, Suzhou,China Postal Code:215129 TEL:+86-512-6841-2350 FAX:+86-512-6841-2356 E-mail : suzhou@chilisin.com.tw</p>
---	---

DRAWN BY 溫美玲 ling	CHECKED BY 張麗玲 ll.chang	APPROVED BY 陳瑞揚 ryan.chen
-----------------------------	-----------------------------------	-------------------------------------

SCDS105R Series Specification

1 Scope: This specification applies to SMD POWER CHOKE

2 Part Numbering: Product Identification

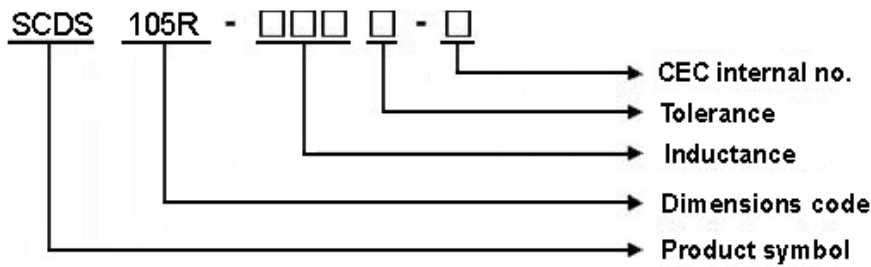

3 Rating:

Operating Temperature: $-40^{\circ}\text{C} \sim 105^{\circ}\text{C}$ (Including self - temperature rise)

Storage Temperature: Under 25°C , Humidity < 75% RH

4 Marking:

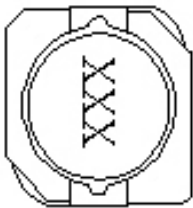

Ex: SCDS105R-100T-N

Marking: 100

Marking color : Black

5 Standard Testing Condition

	Unless otherwise specified	In case of doubt
Temperature	Ordinary Temperature(15 to 35°C)	20±2°C
Humidity	Ordinary Humidity(25 to 85% RH)	60 to 70 % RH

SCDS105R Series Specification

6 Configuration and Dimensions:

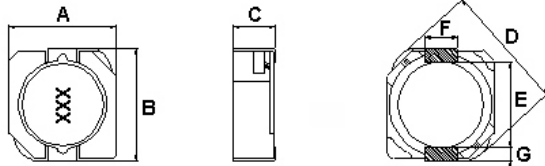

TYPE	A m/m	B m/m	C m/m	D m/m	E m/m	F m/m	G m/m
SCDS105R	10.3 ⁺⁰	10.5 ⁺⁰	5.1 ⁺⁰	13.5 ⁺⁰	7.7	3.0	1.2

7 ELECTRICAL CHARACTERISTICS :

Part No.	Inductance (uH)	Test Freq.	RDC (Ω)Max.	Isat (A)	Tolerance	Marking
SCDS105R-R80□-N	0.8	100 kHz,1 V	0.0043	13.5	T	R80
SCDS105R-1R5□-N	1.5	100 kHz,1 V	0.0058	10.5	T	1R5
SCDS105R-2R2□-N	2.2	100 kHz,1 V	0.0072	9.25	T	2R2
SCDS105R-3R3□-N	3.3	100 kHz,1 V	0.0104	7.8	T	3R3
SCDS105R-4R7□-N	4.7	100 kHz,1 V	0.0123	6.4	T	4R7
SCDS105R-6R8□-N	6.8	100 kHz,1 V	0.018	5.4	T	6R8
SCDS105R-8R2□-N	8.2	100 kHz,1 V	0.02	4.85	T	8R2
SCDS105R-100□-N	10	100 kHz,1 V	0.026	4.45	M,T	100
SCDS105R-120□-N	12	100 kHz,1 V	0.033	4	M,T	120
SCDS105R-150□-N	15	100 kHz,1 V	0.041	3.6	M,T	150
SCDS105R-180□-N	18	100 kHz,1 V	0.046	3.2	M,T	180
SCDS105R-220□-N	22	100 kHz,1 V	0.061	2.95	M,T	220
SCDS105R-270□-N	27	100 kHz,1 V	0.069	2.7	M,T	270
SCDS105R-330□-N	33	100 kHz,1 V	0.084	2.5	M,T	330
SCDS105R-390□-N	39	100 kHz,1 V	0.106	2.3	M,T	390
SCDS105R-470□-N	47	100 kHz,1 V	0.13	2	M,T	470
SCDS105R-560□-N	56	100 kHz,1 V	0.149	1.9Typ	M,T	560
SCDS105R-680□-N	68	100 kHz,1 V	0.201	1.65	M,T	680
SCDS105R-820□-N	82	100 kHz,1 V	0.227	1.5	M,T	820
SCDS105R-101□-N	100	100 kHz,1 V	0.253	1.35	M,T	101
SCDS105R-121□-N	120	100 kHz,1 V	0.303	1.28	M,T	121
SCDS105R-151□-N	150	100 kHz,1 V	0.37	1.12	M,T	151
SCDS105R-181□-N	180	100 kHz,1 V	0.419	1.04	M,T	181
SCDS105R-221□-N	220	100 kHz,1 V	0.5	0.94	M,T	221
SCDS105R-271□-N	270	100 kHz,1 V	0.672	0.84	M,T	271

NOTE: □-tolerance M=±20% / T=±30%

1. Operating temperature range - 40°C ~ 105°C (Including self - temperature rise)

2. Isat: Inductance drop = 35% typ.

"-N" FOR COMPLETELY LEAD FREE TYPE (INCLUDING FERRITE BODY & SOLDER)



ISO9001 & ISO14001 & TS16949 **CHILISIN ELECTRONICS CORP.**

SCDS105R Series Specification

Part No.	Inductance (μ H)	Test Freq.	RDC (Ω)Max.	Isat (A)	Tolerance	Marking
SCDS105R-331□-N	330	100 kHz, 1 V	0.812	0.75	M,T	331
SCDS105R-391□-N	390	100 kHz, 1 V	0.953	0.7	M,T	391
SCDS105R-471□-N	470	100 kHz, 1 V	1.29	0.6	M,T	471
SCDS105R-561□-N	560	100 kHz, 1 V	1.43	0.54	M,T	561
SCDS105R-681□-N	680	100 kHz, 1 V	1.6	0.52	M,T	681
SCDS105R-821□-N	820	100 kHz, 1 V	1.77	0.5	M,T	821
SCDS105R-102□-N	1000	100 kHz, 1 V	1.99	0.48	M,T	102

SCDS105R Series Specification

8 SCDS105R Series

8.1 Construction:

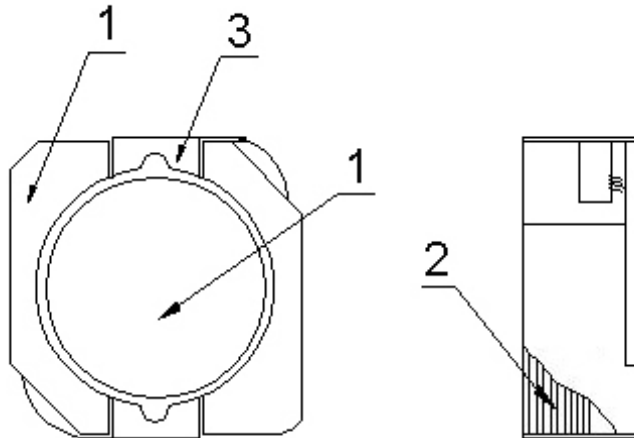

8.2 Material List:

ITEM	PART	DESCRIPTION	SUPPLIES
1	CORE	FERRITE	CHILISIN
2	WIRE	MAGNET WIRE	
3	TERMINAL	TERMINAL COPPER	CHILISIN



SCDS105R Series Specification

9 Reliability Of Ferrite Wire Wound Power Inductor

1-1.Mechanical Performance

No	Item	Specification	Test Method
1-1-1	Vibration	Appearance: No damage Inductance: within $\pm 10\%$ of initial value	Test device shall be soldered on the substrate Oscillation Frequency: 10 to 55 to 10Hz for 1min Amplitude: 1.5mm Time: 2hrs for each axis (X, Y & Z), total 6hrs
1-1-2	Resistance to Soldering Heat	Appearance: No damage	Pre-heating: 150°C, 1min Solder Composition: Sn/Ag3.0/Cu0.5 Solder Temperature: 260 \pm 5°C Immersion Time: 10 \pm 1sec
1-1-3	Solder ability	The electrodes shall be at least 95% covered with new solder coating	Pre-heating: 150°C, 1min Solder Composition: Sn/Ag3.0/Cu0.5 Solder Temperature: 245 \pm 5°C Immersion Time: 4 \pm 1sec
1-1-4	Resistance to solvent	There must be no change in appearance or obliteration of marking.	Inductors must withstand 6 minutes of alcohol or water.

1-2.Environmental Performance

No	Item	Specification	Test Method															
1-2-1	Temperature Shock	Appearance: No damage Inductance: within $\pm 10\%$ of initial value	10 cycles (Air to Air) 1 cycles shall consist of: 30 minutes exposure to -55 °C 30 minutes exposure to 125 °C 15 seconds maximum transition between temperatures															
1-2-2	Temperature Cycle		One cycle: <table border="1" style="width: 100%; border-collapse: collapse;"> <thead> <tr> <th>Step</th> <th>Temperature (°C)</th> <th>Time (min)</th> </tr> </thead> <tbody> <tr> <td>1</td> <td>-40\pm3</td> <td>30</td> </tr> <tr> <td>2</td> <td>25\pm2</td> <td>3</td> </tr> <tr> <td>3</td> <td>105\pm3</td> <td>30</td> </tr> <tr> <td>4</td> <td>25\pm2</td> <td>3</td> </tr> </tbody> </table>	Step	Temperature (°C)	Time (min)	1	-40 \pm 3	30	2	25 \pm 2	3	3	105 \pm 3	30	4	25 \pm 2	3
Step	Temperature (°C)		Time (min)															
1	-40 \pm 3		30															
2	25 \pm 2		3															
3	105 \pm 3	30																
4	25 \pm 2	3																
1-2-3	Humidity Resistance	Temperature: 40 \pm 2°C Relative Humidity: 90 ~ 95% Time: 1000hrs Measured after exposure in the room condition for 24hrs																
1-2-4	Heat Life	Temperature: 85 \pm 3°C Relative Humidity: 20% Applied Current: Rated Current Time: 1000hrs Measured after exposure in the room condition for 24hrs																
1-2-5	Cold Resistance	Temperature: -40 \pm 3°C Relative Humidity: 0% Time: 1000hrs Measured after exposure in the room condition for 24hrs																

SCDS105R Series Specification

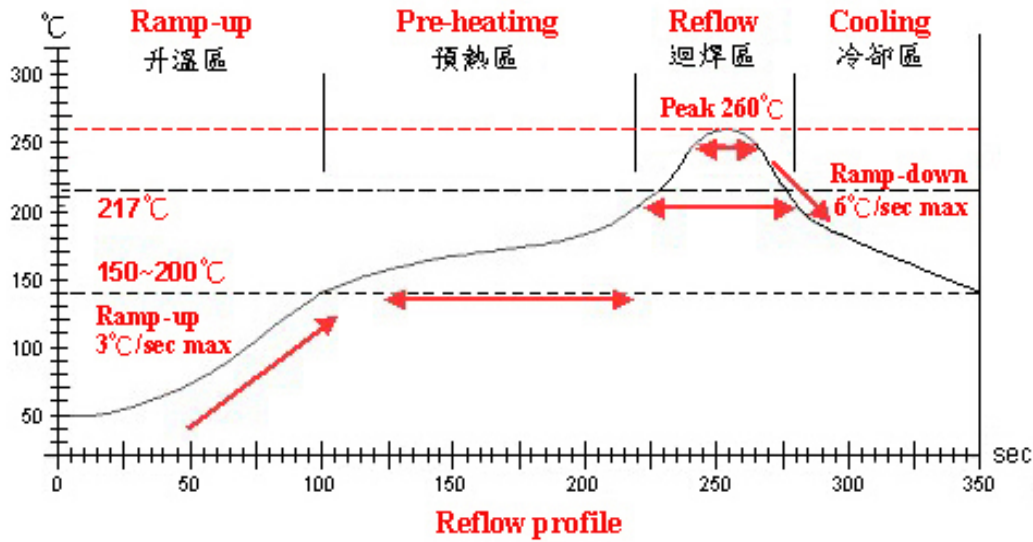

Lead-Free(LF) 標準溫度分析範圍

Refer to J-STD-020C

管制項目 Item.	升温區 Ramp-up	預熱區 Pre-heating	迴焊區 Reflow	Peak Temp	冷卻區 Cooling
溫度範圍 Temp.scope	R.T. ~ 150°C	150°C ~ 200°C	217°C	260±5°C	Peak Temp. ~ 150°C
標準時間 Time spec.	—	60 ~ 180 sec	60 ~ 150sec	20 ~ 40 sec	—
實際時間 Time result	—	75 ~ 100 sec	90 ~ 120sec	20 ~ 35 sec	—

SCDS105R Series Specification

11 PACKAGING

11.1 Packaging -Cover tape

The force for tearing off cover tape is 10 to 130 grams in the arrow direction.

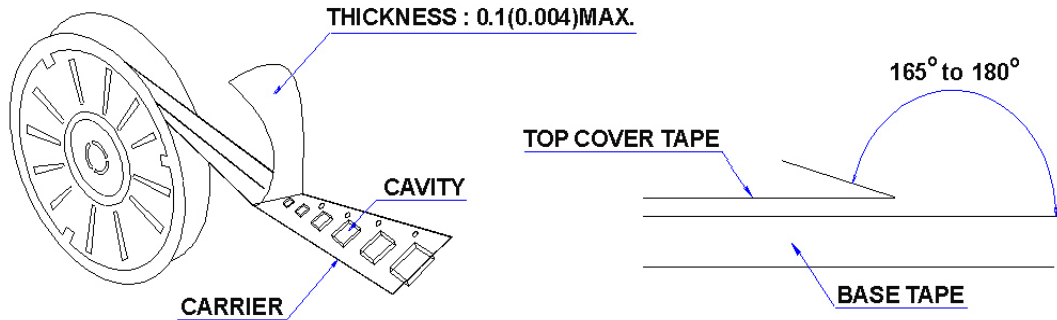

11.2 Packaging Quantity

TYPE	BULK	PCS/REEL
SCDS105R	✓	500

11.3 Reel Dimensions

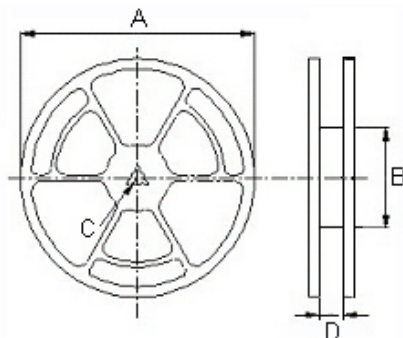

Reel Dimensions : m/m

TYPE	A	B	C	D
SCDS105R	330	100	13	24.4

SCDS105R Series Specification

11 PACKAGING

11.4 Tape Dimensions in mm

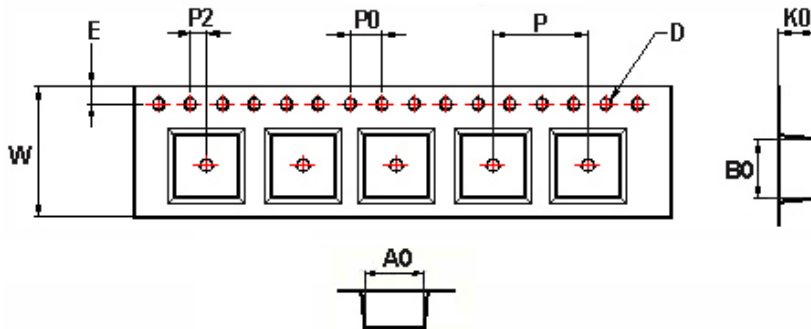

TYPE	A0	B0	K0	D	E	W	P	P0	P2
SCDS105R	10.6	10.6	5.0	1.55	1.75	24	16	4	2

12 Recommended Pattern

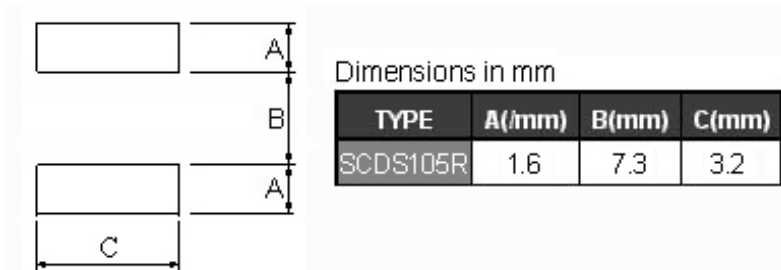

13 Note:

1. Please make sure that your product is has been evaluated and confirmed against your specifications when our product is mounted to your product.
2. Do not knock nor drop.
3. All the items and parameters in this product specification have been prescribed on the premise that our product is used for the purpose, under the condition and in the environment agreed upon between you and us. You are requested not to use our product deviating from such agreement.
4. Please keep the distance between transformer/coil and other components (refer to the standard IEC 950)