



ISO9001 & ISO14001 & TS16949 **CHILISIN ELECTRONICS CORP.**

Halogen Free & RoHs Compliance

SPECIFICATION FOR APPROVAL

CUSTOMER : Eltech

CUSTOMER P/N : _____

OUR DWG No : _____

QUANTITY : 0 Pcs. **DATE :** 2014/06/24

ITEM : PBY060303T-Series-N

SPECIFICATION ACCEPTED BY:	
COMPONENT ENGINEER	
ELECTRICAL ENGINEER	
MECHANICAL ENGINEER	
APPROVED	
REJECTED	

<p>奇力新電子股份有限公司 Chilisin Electronic sCorp No. 29, Alley 301, Tehhsin Rd., Hukou,Hsinchu 303, Taiwan TEL : +886-3- 599-2646 FAX : +886-3- 599-9176 E-mail : sales@chilisin.com.tw http : //www.chilisin.com.tw</p>	<p>東莞奇力新電子有限公司 Chilisin Electronics (Dongguan) Co., Ltd. No. 78, Puxing Rd., Yuliangwei Administration Area, Qingxi Town, Dongguan City, Guangdong,China TEL : +86-769-8773-0251~3 FAX : +86-769-8773-0232 E-mail : cect@chilisin.com.tw</p>
<p>奇力新電子(河南)有限公司 Chilisin Electronics (Henan) Co., Ltd. XiuWu Xian, industry gathering area JiaoZuo, Henan China Postal Code:454350 TEL:+86-391-717-0682 FAX:+86-391-717-0666</p>	<p>奇力新電子(蘇州)有限公司 Chilisin Electronics (Suzhou) Co., Ltd. No.143,Song Shan Rd., Suzhou New District, Suzhou,China Postal Code:215129 TEL:+86-512-6841-2350 FAX:+86-512-6841-2356 E-mail : suzhou@chilisin.com.tw</p>

DRAWN BY 王巧雲 gina.wang	CHECKED BY 溫美玲 ling	APPROVED BY 詹嘉皓 allen.chan
---	--------------------------------------	---

PBY060303T Series Specification

1 Scope: This specification applies to MULTILAYER FERRITE CHIP BEADS

2 Part Numbering: Product Identification

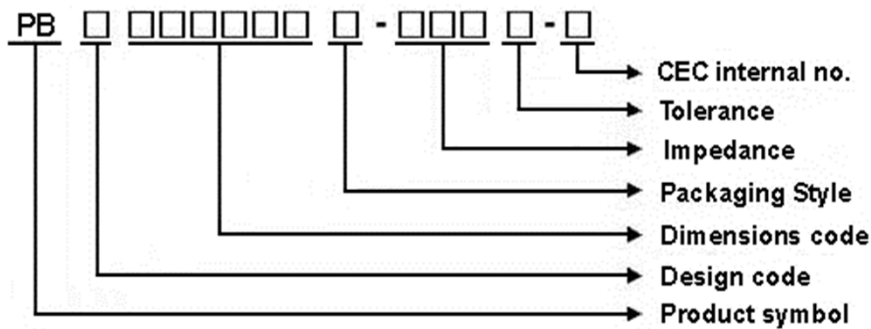

3 Rating:

Operating Temperature: - 5 5 °C ~ 1 2 5 °C (Including self - temperature rise)

Storage Temperature: - 5 5 °C ~ 1 2 5 °C (after PCB)

- 5 °C ~ 4 0 °C, Humidity 4 0 % ~ 7 0 % (before PCB)

4 Marking:

No Marking

5 Standard Testing Condition

	Unless otherwise specified	In case of doubt
Temperature	Ordinary Temperature(15 to 35°C)	20±2°C
Humidity	Ordinary Humidity(25 to 85% RH)	60 to 70 % RH

PBY060303T Series Specification

6 Configuration and Dimensions:

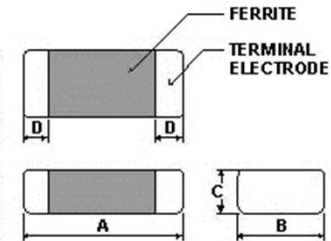

Dimensions in mm

TYPE	PB060303
A	0.60±0.03
B	0.30±0.03
C	0.30±0.03
D	0.15±0.05

7 ELECTRICAL CHARACTERISTICS :

Part No.	Impedance (Ω)	Test Freq.	RDC (Ω)Max.	Rated Current (mA)Max.
PBY060303T-10□-N	10	100 MHz,200 mV	0.05	1000
PBY060303T-22□-N	22	100 MHz,200 mV	0.065	1000
PBY060303T-33□-N	33	100 MHz,200 mV	0.09	750
PBY060303T-47□-N	47	100 MHz,200 mV	0.12	500

NOTE: □-tolerance Y=±25% / T=±30%

1. Operating temperature range - 5 5°C ~ 1 2 5°C (Including self - temperature rise)
 2. Rate Current : Applied the current to coils, the temperature rise shall not be more than 30°C
 3. As for PB/UPB type. Rated Current is derated as left figure depending on the operating temperature.
- "-N" FOR COMPLETELY LEAD FREE TYPE(INCLUDING FERRITE BODY & SOLDER)

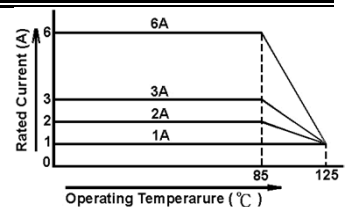

PBY060303T Series Specification

8 PBY060303T Series

8.1 Construction:

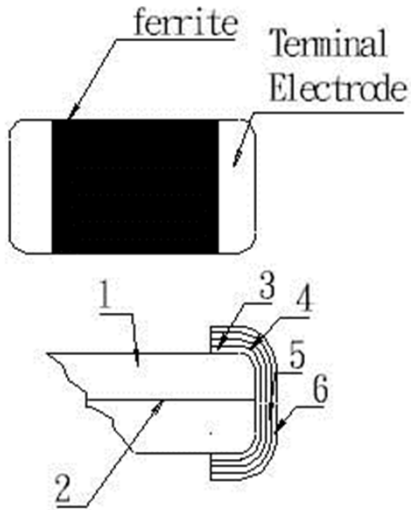

8.2 Material List:

NO	PART	MATERIAL
1	Ferrite Substance	NiO-CuO-ZnO-Ferrite
2	Silver electrode	Ag
3	Silver electrode	Ag
4	Cu plating	Cu
5	Ni plating	Ni
6	Sn plating	Sn

PB060303T Series Specification

9 Reliability Of Ferrite Multilayer Chip Bead

1-1. Mechanical Performance

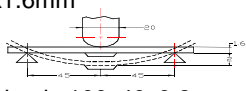
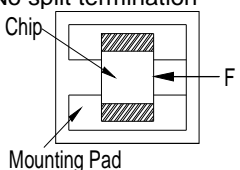
No	Item	Specification	Test Method
1-1-1	Flexure Strength	The forces applied on the right conditions must not damage the terminal electrode and the ferrite	Test device shall be soldered on the substrate Substrate Dimension: 100x40x1.6mm Deflection: 2.0mm Keeping Time: 30sec *For 100505, substrate dimension is 100x40x0.8mm 
1-1-2	Vibration		
1-1-3	Resistance to Soldering Heat	Appearance: No damage More than 75% of the terminal electrode should be covered with solder. Impedance : within $\pm 30\%$ of initial value	Pre-heating: 150°C, 1min Solder Composition: Sn/Ag3.0/Cu0.5(Pb-Free) Solder Temperature: 260 \pm 5°C Immersion Time: 10 \pm 1sec
1-1-4	Solder ability	The electrodes shall be at least 95% covered with new solder coating	Pre-heating: 150°C, 1min Solder Composition: Sn/Ag3.0/Cu0.5(Pb-Free) Solder Temperature: 245 \pm 5°C (Pb-Free) Immersion Time: 4 \pm 1sec
1-1-5	Terminal Strength Test	No split termination 	Test device shall be soldered on the substrate, then apply a force in the direction of the arrow. Force : 2N Keeping Time: 10 \pm 1sec

1-2. Environmental Performance

No	Item	Specification	Test Method															
1-2-1	Temperature Cycle	Appearance: No damage Impedance: within $\pm 30\%$ of initial value	One cycle:															
			<table border="1"> <thead> <tr> <th>Step</th> <th>Temperature (°C)</th> <th>Time (min)</th> </tr> </thead> <tbody> <tr> <td>1</td> <td>-55\pm3</td> <td>30</td> </tr> <tr> <td>2</td> <td>25\pm2</td> <td>3</td> </tr> <tr> <td>3</td> <td>125\pm3</td> <td>30</td> </tr> <tr> <td>4</td> <td>25\pm2</td> <td>3</td> </tr> </tbody> </table>	Step	Temperature (°C)	Time (min)	1	-55 \pm 3	30	2	25 \pm 2	3	3	125 \pm 3	30	4	25 \pm 2	3
			Step	Temperature (°C)	Time (min)													
			1	-55 \pm 3	30													
			2	25 \pm 2	3													
3	125 \pm 3	30																
4	25 \pm 2	3																
Total: 100cycles																		
Measured after exposure in the room condition for 24hrs																		
Temperature: 40 \pm 2°C																		
1-2-2	Humidity Resistance		Relative Humidity: 90 ~ 95% / Time: 1000hrs Measured after exposure in the room condition for 24hrs															
1-2-3	High Temperature Resistance		Temperature: 125 \pm 3°C / Relative Humidity: 0% Applied Current: Rated Current / Time: 1000hrs Measured after exposure in the room condition for 24hrs															
1-2-4	Low Temperature Resistance		Temperature: -55 \pm 3°C Relative Humidity: 0% / Time: 1000hrs Measured after exposure in the room condition for 24hrs															

PBY060303T Series Specification

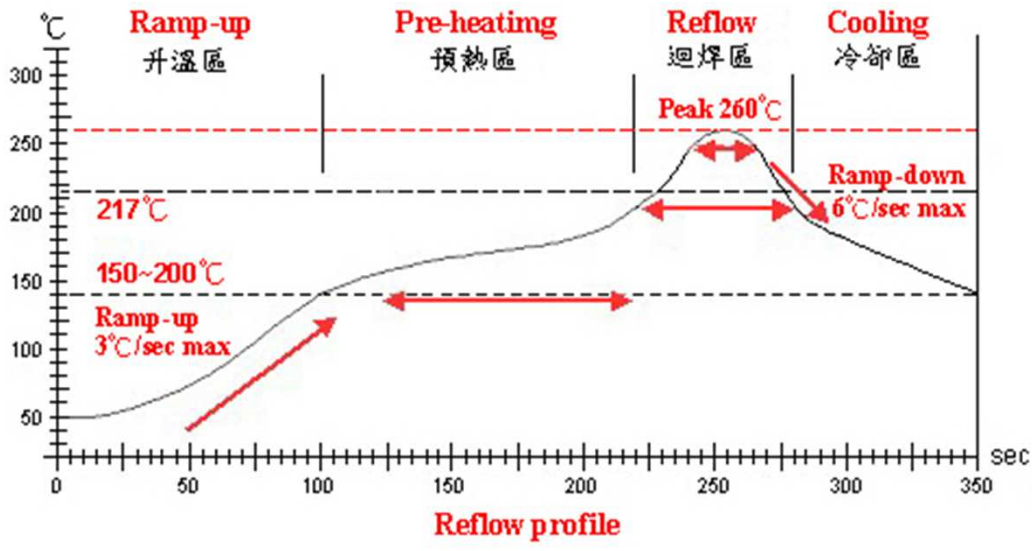

Lead-Free(LF) 標準溫度分析範圍

Refer to J-STD-020C

管制項目 Item.	升温區 Ramp-up	预热區 Pre-heating	迴焊區 Reflow	Peak Temp	冷却區 Cooling
溫度範圍 Temp.scope	R.T. ~ 150°C	150°C ~ 200°C	217°C	260±5°C	Peak Temp. ~ 150°C
標準時間 Time spec.	—	60 ~ 180 sec	60 ~ 150sec	20 ~ 40 sec	—
實際時間 Time result	—	75 ~ 100 sec	90 ~ 120sec	20 ~ 35 sec	—

NOTE :

1. Re-flow possible times : within 2 times
2. Nitrogen adopted is recommended while in re-flow

PBY060303T Series Specification

11 PACKAGING

11.1 Packaging -Cover tape

The force for tearing off cover tape is 10 to 100 grams in the arrow direction.

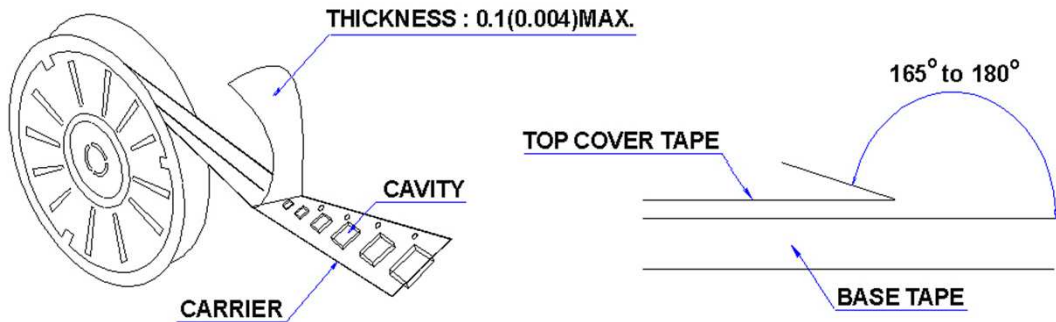

11.2 Packaging Quantity

TYPE	BULK	PCS/REEL
PB060303	✓	15000
PB100505	✓	10000
PB160808	✓	4000
PB201209	✓	4000

11.3 Reel Dimensions

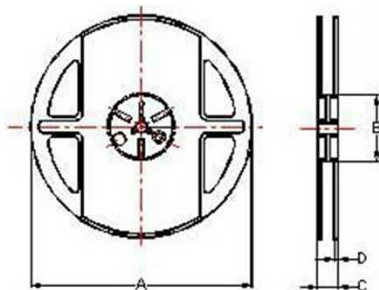

Dimensions in mm

TYPE	A	B	C	D
PB060303	178	60	12	1.5
PB100505	178	60	12	1.5
PB160808	178	60	12	1.5
PB201209	178	60	12	1.5

PBY060303T Series Specification

11 PACKAGING

11.4 Tape Dimensions in mm

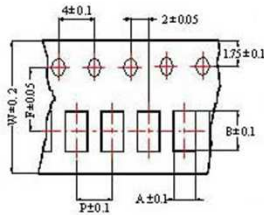

Tape Material

Carrier tape : Paper

Cover tape : Polyethylene

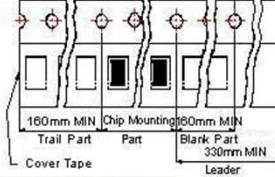

TYPE	A	B	T	W	P	F
PB060303	0.38	0.68	0.34	8	2	3.5
PB100505	0.65	1.15	0.60	8	2	3.5
PB160808	1.05	1.85	0.95	8	4	3.5
PB201209	1.50	2.30	0.97	8	4	3.5

12 Recommended Pattern

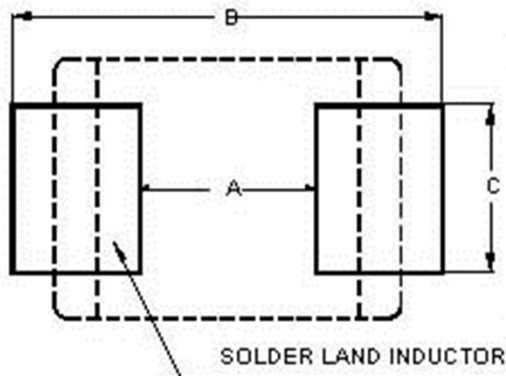

Dimensions in mm

TYPE	A	B	C
PB060303	0.2~0.3	0.75~1.05	0.3
PB100505	0.4	1.2 ~ 1.4	0.5
PB160808	0.7 ~ 0.8	1.8 ~ 2.0	0.6 ~ 0.8
PB201209	1.0 ~ 1.2	2.6 ~ 4.0	1.0 ~ 1.2

13 Note:

1. Please make sure that your product has been evaluated and confirmed against your specifications when our product is mounted to your product.
2. Do not knock nor drop.
3. All the items and parameters in this product specification have been prescribed on the premise that our product is used for the purpose, under the condition and in the environment agreed upon between you and us. You are requested not to use our product deviating from such agreement.
4. Please keep the distance between transformer/coil and other components (refer to the standard IEC 950)