

QUADMO747-X/T30

Qseven® Module with NVIDIA® Tegra® T30 Processor

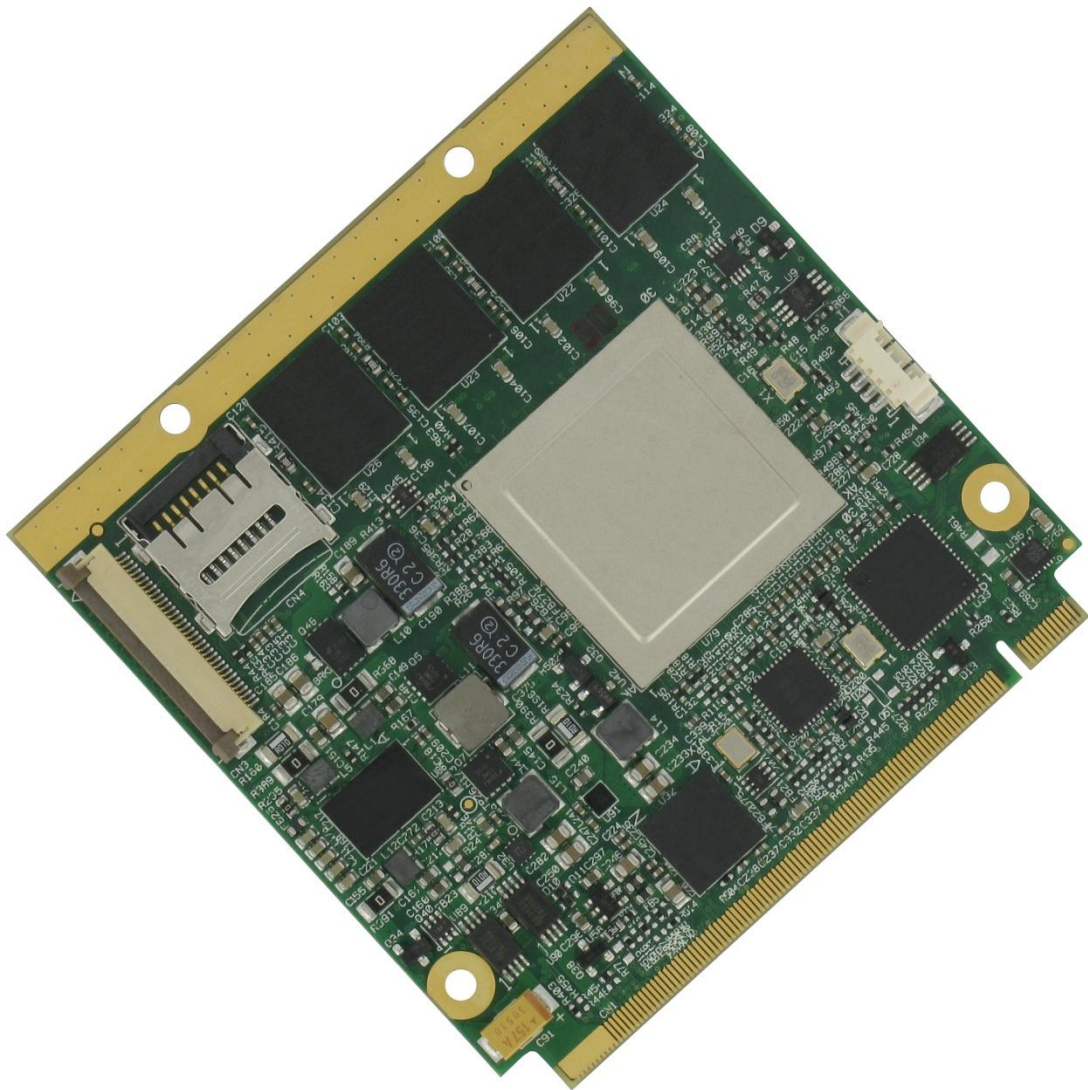

User Manual



QUADMO747-X/T30

REVISION HISTORY

Revision	Date	Note	Rif.
1.0	12 th June 2012	First release	SB

All rights reserved. All information contained in this manual is proprietary and confidential material of SECO S.r.l.

Unauthorised use, duplication, modification or disclosure of the information to a third-party by any means without prior consent of SECO S.r.l. is prohibited.

Every effort is been made to ensure the accuracy of this manual; however, SECO S.r.l. accepts no responsibility for any inaccuracies, errors or omissions herein. SECO S.r.l. reserves the right to change precise specifications without prior notice to supply the best product possible.

For further information as regards this module or other SECO products please visit our websites at <http://www.seco.com> and <http://www.secoqseven.com>.

Moreover in order to have the proper assistance for any possible issue please complete your registration online on our specific website for Qseven modules (<http://www.secoqseven.com>).

Our team will be pleased and ready to assist you.

SECO Srl - Via Calamandrei 91
52100 Arezzo – ITALY
Ph: +39 0575 26979 - Fax: +39 0575 350210
<http://www.secoqseven.com>
<http://www.seco.com>



INDEX

CHAPTER 1. INTRODUCTION	4
1.1 WARRANTY.....	5
1.2 INFORMATION AND ASSISTANCE	6
1.3 RMA NUMBER REQUEST	6
1.4 SAFETY	7
1.5 ELECTROSTATIC DISCHARGES	7
1.6 ROHS COMPLIANCE	7
CHAPTER 2. OVERVIEW	8
2.1 INTRODUCTION.....	9
2.2 TECHNICAL SPECIFICATIONS.....	10
2.3 ELECTRICAL SPECIFICATIONS.....	11
2.3.1 <i>Power Consumption</i>	11
2.4 SUPPORTED OPERATING SYSTEMS	11
2.5 MECHANICAL SPECIFICATIONS	11
2.6 BLOCK DIAGRAM	12
CHAPTER 3. CONNECTORS	13
3.1 CONNECTORS OVERVIEW	14
3.2 CONNECTORS DESCRIPTION	15
3.2.1 <i>FFC/FPC Camera Interface</i>	15
3.2.2 <i>MicroSD Card Slot</i>	15
3.2.3 <i>Qseven® Connector</i>	16
3.2.4 <i>SECOQseven philosophy's specific signals.</i>	19
3.2.5 <i>Quadmo747-X/T30 errata</i>	19
3.2.6 <i>Optional signals.</i>	20
3.2.7 <i>JTAG signals</i>	20

Chapter 1. INTRODUCTION

- Warranty
- Information and assistance
- RMA number request
- Safety
- Electrostatic Discharges
- RoHS compliance

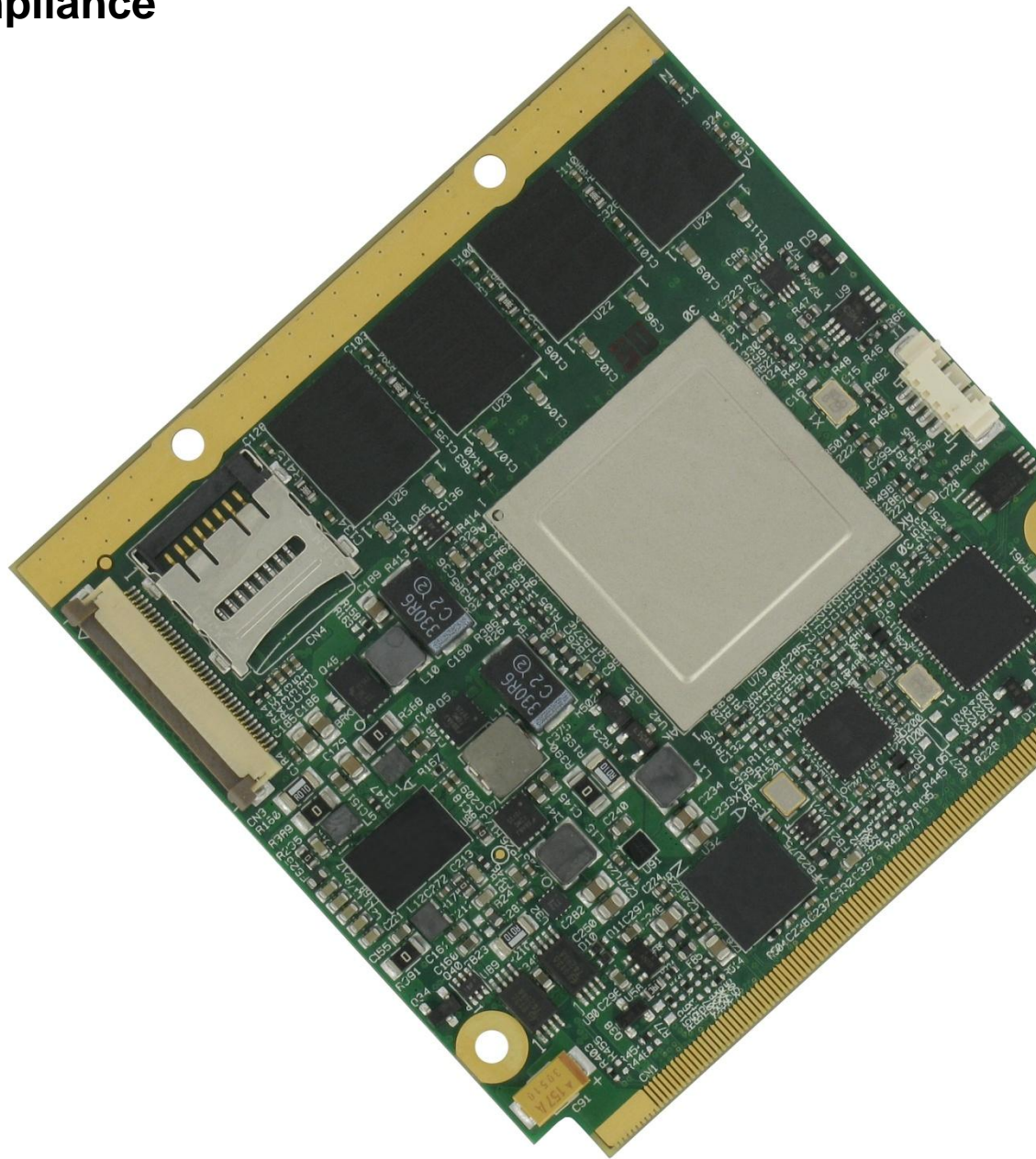

1.1 Warranty

This product is subject to Italian law D. Lgs 24/2002, acting European Directive 1999/44/CE on arguments of sale and warranties to consumer.

The warranty for this product lasts 1 year

Under the warranty period the Supplier guarantees the buyer an assistance service for repairing, replacing or credit of the item, at its own discretion.

Shipping costs regarding non-conforming items or items that need replacement, are to be paid by the customer.

Items cannot be returned unless formerly authorised by the supplier.

The authorisation is released after compiling the specific form available from the web-site <http://www.seco.com> (RMA Online). Authorisation number for returning the item must be put both on the packaging and on the documents brought with the items, which have to be not damaged, not tampered, with all accessories in their original packaging.

Error analysis form identifying the fault type has to be compiled by the customer and has to be sent in the packaging of the returned item.

If some of the above mentioned requirements for returning the item is not satisfied, item will be shipped back and customer will have to pay for shipping costs.

The supplier, after a technical analysis, will verify if all the requirements for warranty service are met. If warranty can not be applied, he calculates the minimum cost of this initial analysis on the item and the repairing costs. Costs for replaced components will be calculated aside.

Warning!



All changes or modifications to the equipment not clearly approved by SECO S.r.l. could impair equipment's functionality and lead to the expire of the warranty

1.2 Information and assistance

What do I have to do if the product is faulty?

SECO S.r.l. offers the following services:

- **SECO website:** visit <http://www.secoqseven.com> to receive the last information on the product. In most of the cases you can find useful information to resolve your problem.
- **SECO reseller:** the reseller or agent can help you in determining the exact cause of the problem and search the best solution for it.
- **SECO Help-Desk:** contact SECO Technical Assistance.

A technician is at your disposal to understand the exact origin of the problem and suggest the right solution.

E-mail: technical.service@seco.com

Fax (+39) 0575 340434

- **Repairing centre:** it is possible to send the faulty product to SECO Repairing Centre. In this case, follow this procedure:
 - Returned items have to be provided with RMA Number. Items sent without RMA number will be not accepted.
 - Returned items have to be packed in the appropriate manner. SECO is not responsible for damages caused by accidental drop, improper usage, or customer neglects.

Note: We ask to prepare the following information before asking for technical assistance:

- Name and serial number of the product;
- Description of Customer's peripheral connections;
- Description of Customer's software (operative system, version, application software, etc.);
- A complete description of the problem;
- The exact words of every kind of error message received

1.3 RMA number request

To request a RMA number, please, visit SECO's web-site. In the home-page select "RMA Online" and follow the described procedure

You will receive an RMA Number within 1 working day (only for on-line RMA request).

1.4 Safety

Quadmo747-X/T30 module only uses extremely-low voltages.

While handling the board, it is necessary to be careful in order to avoid any kind of risk or damages to electronic components. Always switch the power off, and unplug the power supply unit, before handling the board and/or connecting cables or other boards.

Don't use metallic components, like paper clips, screws and similar, near the board, when this is supplied, to avoid short circuits due to unwanted contacts with other components of the board.

Never connect the board to an external power supply unit or battery, if the board has become wet.

Make sure that all cables are correctly connected and are not damaged.

1.5 Electrostatic Discharges

Quadmo747-X/T30, like any other electronic product, is an electrostatic sensitive device and some device on-board could be damaged by high voltages caused by static electricity.

So whenever handling a Quadmo747-X/T30 board, take care to ground yourself through an anti-static wrist strap. Placement of the board on an anti-static surface is also highly recommended.

1.6 RoHS compliance

Quadmo747-X/T30 board is designed using RoHS compliant components and is manufactured on a lead-free production line. It is therefore fully RoHS compliant.

Chapter 2. OVERVIEW

- Introduction
- Technical Specifications
- Electrical specifications
- Mechanical specifications
- Block diagram

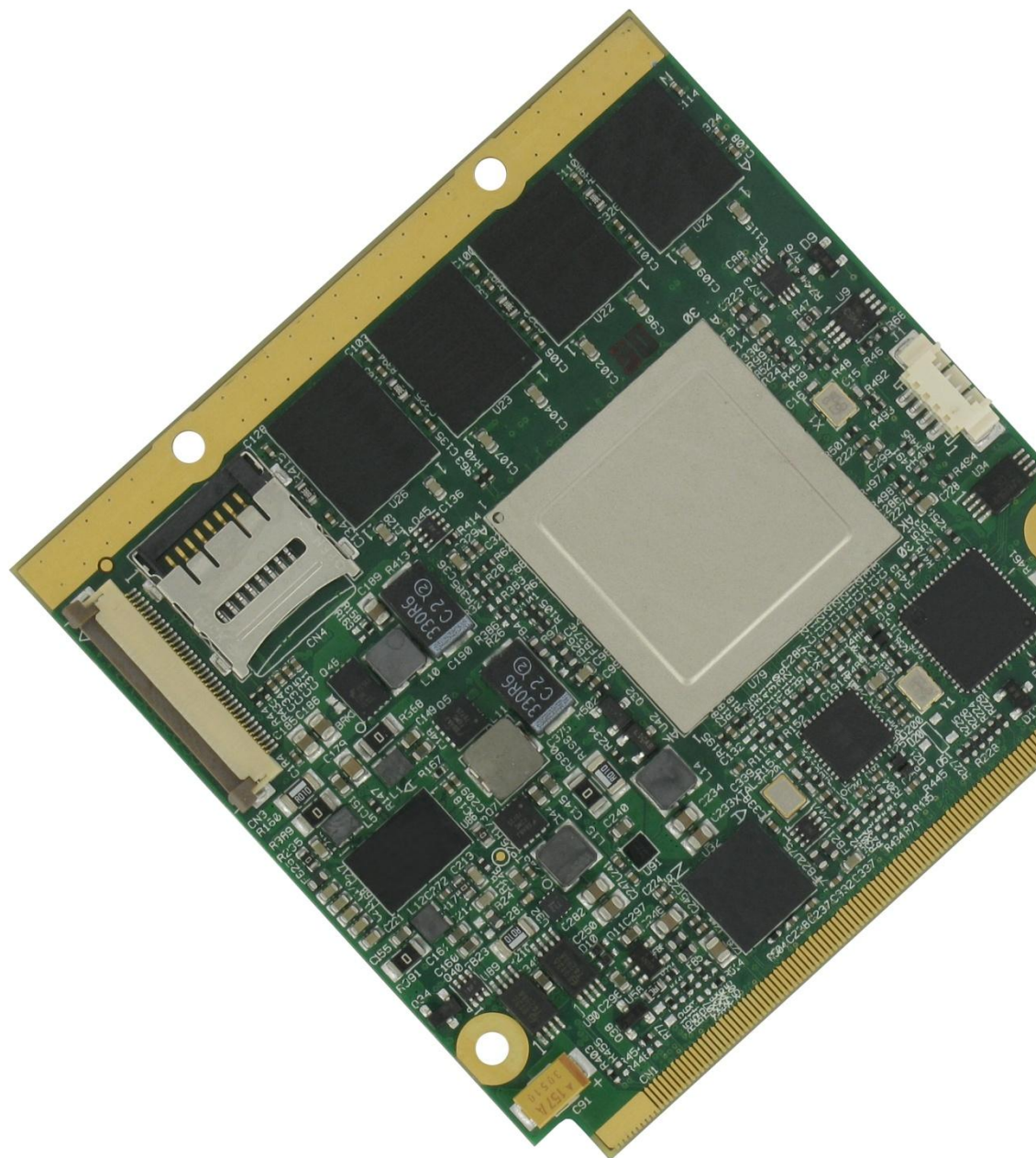

2.1 Introduction

Quadmo747-X/T30 is a CPU module, in new Qseven[®] format, based on embedded NVIDIA[®] T30 (Tegra[®] 3) processor, a Quad Core ARM[®] Cortex[®]-A9 microprocessor that offer top performances for graphical and computational applications based on low power ARM architectures.

Along with programmable CPLD Lattice LCMXO640, the board offers a very high level of integration, both for all most common used peripherals in ARM world and for bus interfaces normally used in x86 world, like PCI-Express and S-ATA.

All this comes out in the extremely reduced space offered by Qseven[®] boards, which offers all functionalities of standard boards in just 70x70mm.

This solution allows combining the advantages of a standard, ready-to-use board, like Qseven[®] boards are, with all advantages offered by ARM application specific processors like NVIDIA[®] Tegra[®] 3, with an integrated Quad Core ARM Cortex-A9, with frequency of 1.4 GHz per core.

Each core offers 64KB L1 Cache (32KB data, 32KB instructions), and 1MB of L2 cache.

Moreover, Tegra[®] T30 integrates a very powerful Graphical Processing Unit NVIDIA[®] GeForce ULP, with 12 independent cores, that give the processor incredible graphical performances, both 2D and 3D.

The board is completed with up to 2GB DDR3L directly soldered on board, and one eMMC Flash Disk, directly accessible like any standard Hard Disk, with up to 32GB of capacity.

The board has three display interfaces, up to two can work simultaneously in an independent way: the first one, is a 24 bit Single/Dual Channel LVDS interface, and is obtained by converting internally the first integrated display interface of T30 processor. Second display interface, is Tegra[®] T30's native HDMI interface. The third display interface is Tegra[®] T30's DSI interface.

HW video decoding of the most common coding standard (i.e., H.264, MPEG2, MPEG4, DivX, RealVideo and other) is supported.

On board there can optionally also be a CAN Bus Controller, Microchip MCP2515.

The Lattice CPLD mounted on board, makes available LPC Bus and is also used for conversion of first display interface.

Interface to the board comes through the single card edge connector, as defined by Qseven[®] specifications Rel. 1.20: on this connector, signals are available for Gigabit Ethernet, CAN Interface, the SD/MMC Card interface, up to 6 USB 2.0 ports, 24-bit Single/Dual Channel LVDS, HDMI interface, DSI Interface, 4 x PCI-Express x 1 lanes (can be grouped in 1x PCI-Express x4 lane), HD Audio interface, I²C, LPC, SPI and SM buses, and other features, like 2 x UART and One-Wire.

For external interfacing to standard devices, a carrier board with a 230-pin MXM connector is needed. This board will implement all the routing of the interface signals to external standard connectors, as well as integration of other peripherals/devices not already included in Quadmo747-X/T30 CPU module.

Furthermore, an FFC/FPC connector is provided to give access to Image Processing Unit of T30 processor, which supports multiple formats and can be connected to a wide variety of image sensors for video-preview, video-record and frame grabbing applications. Interfacing is possible using the direct 10bit parallel interface or the integrated MIPI CSI interface (both available on the same connector).

To learn more about Qseven[®] standard: <http://www.qseven-standard.org>.

To learn more about SECOQseven philosophy: <http://www.secoqseven.com>.

2.2 Technical Specifications

- **Processors:** NVIDIA® Tegra® T30 with Quad ARM® CORTEX-A9 MPCore® CPU, 1,3GHz per Core
- **Memory:** Up to 2GB DDR3L onboard
- **Graphic Interface:** embedded NVIDIA® ULP GeForce® GPU
Integrated High Definition Audio-Video Processor
- **Display:** LVDS Single/Dual Channel 18/24 bit interface (resolution up to 1920x1080)
HDMI interface (resolution up to 1920x1080p)
DSI Interface (resolution up to 1440x900 @18bpp, 1366x800@24bpp)
- **Video Input Port / Camera Connector**
- **PCI Express:** 4 x PCI-E x 1 lanes (or 1 x PCI-E x 4)
- **USB:** 6 x USB 2.0 Ports
- **Mass Storage:** On board eMMC, up to 32GB
1 x S-ATA channels
- **Ethernet:** Gigabit Ethernet interface
- **Audio:** HD Audio interface
- **SDIO:** 4 bit SD/MMC interface
- **Serial Ports:** 2x RS-232 Ports
CAN Interface
- **Expansion Bus:** I²C, SM Bus, LPC, SPI, One-Wire
- **JTAG interface**
- **Power Management signals**
- **Power supply voltage:** +5V_{DC} ± 5%
- **Operating temperature:** 0°C ÷ +60°C
- **Dimensions:** 70 x 70 mm (2.756" x 2.756")

User Manual - Rev. First Edition: 1.0 - Last Edition: 1.0 - Author: S.B. - Reviewed by G.M.

2.3 Electrical specifications

According to Qseven[®] specifications, Quadmo747-X/T30 board needs to be supplied only with an external +5V_{DC} power supply.

+5V_{SB} voltage needs to be supplied for working in ATX mode. For Real Time Clock working and CMOS memory data retention, it is also needed a backup battery voltage. All these voltages are supplied directly through card edge fingers (see connector's pinout).

All remaining voltages needed for board's working are generated internally from +5V_{DC} power rail.

2.3.1 Power Consumption

TBM

2.4 Supported Operating Systems

Quadmo747-X/T30 supports the following operating systems:

- Linux
- Android
- Windows EC 7

SECO will offer the BSP (Board Support Package) for these O.S., to reduce at minimum SW development of the board, giving all the drivers and libraries needed for use both the Qseven[®] board and the Carrier Board, according that the Carrier Board is designed following SECOQseven Design Guide, with the same IC's.

For further details, please visit <http://www.secoqseven.com>.

2.5 Mechanical specifications

According to Qseven[®] specifications, board dimensions are: 70 x 70 mm (2.756" x 2.756").

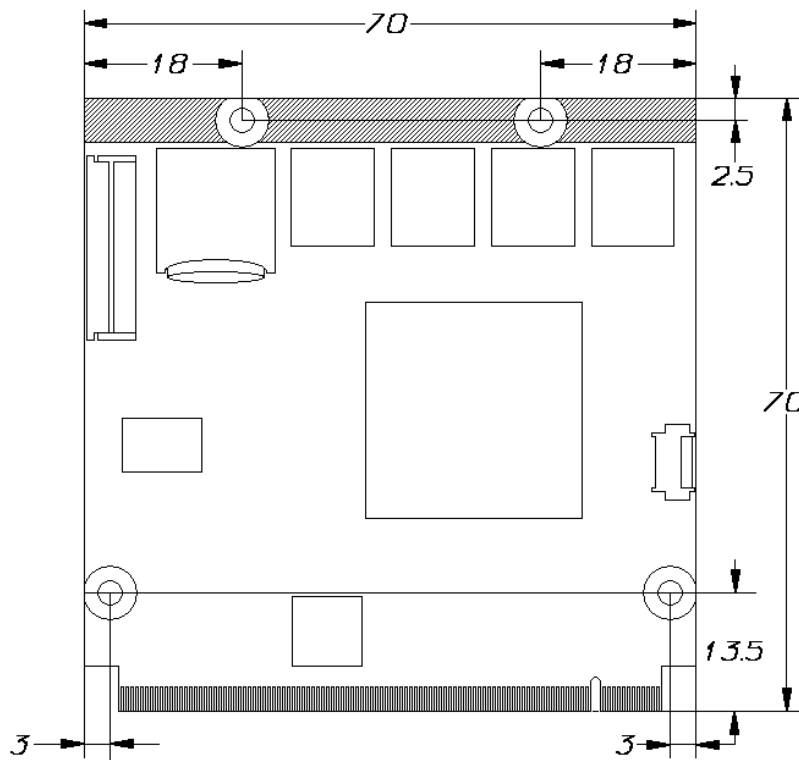

Printed circuit of the board is made of twelve layers, some of them are ground planes, for noise rejection.

2.6 Block diagram

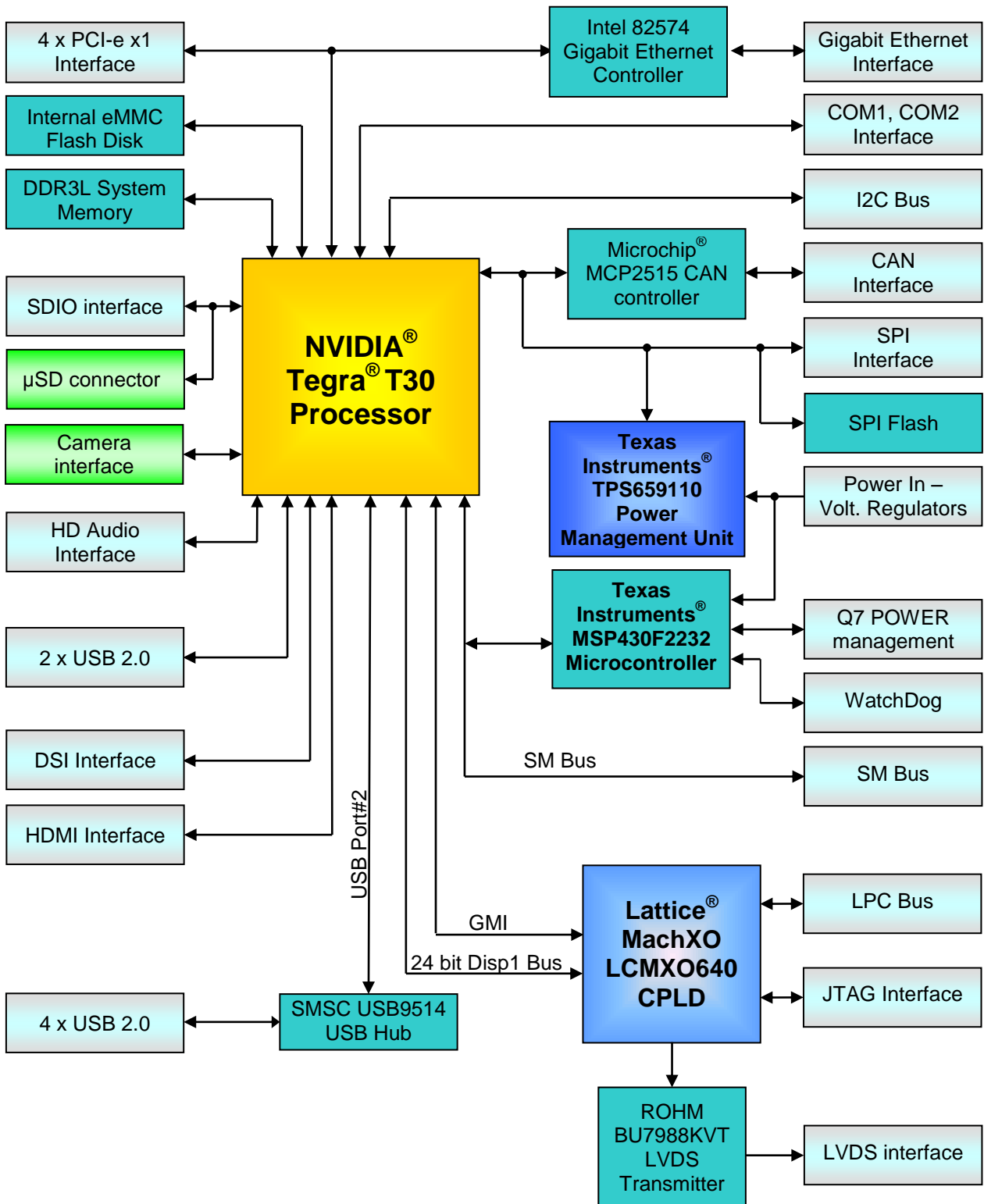

Chapter 3. CONNECTORS

- Connectors overview
- Connectors description

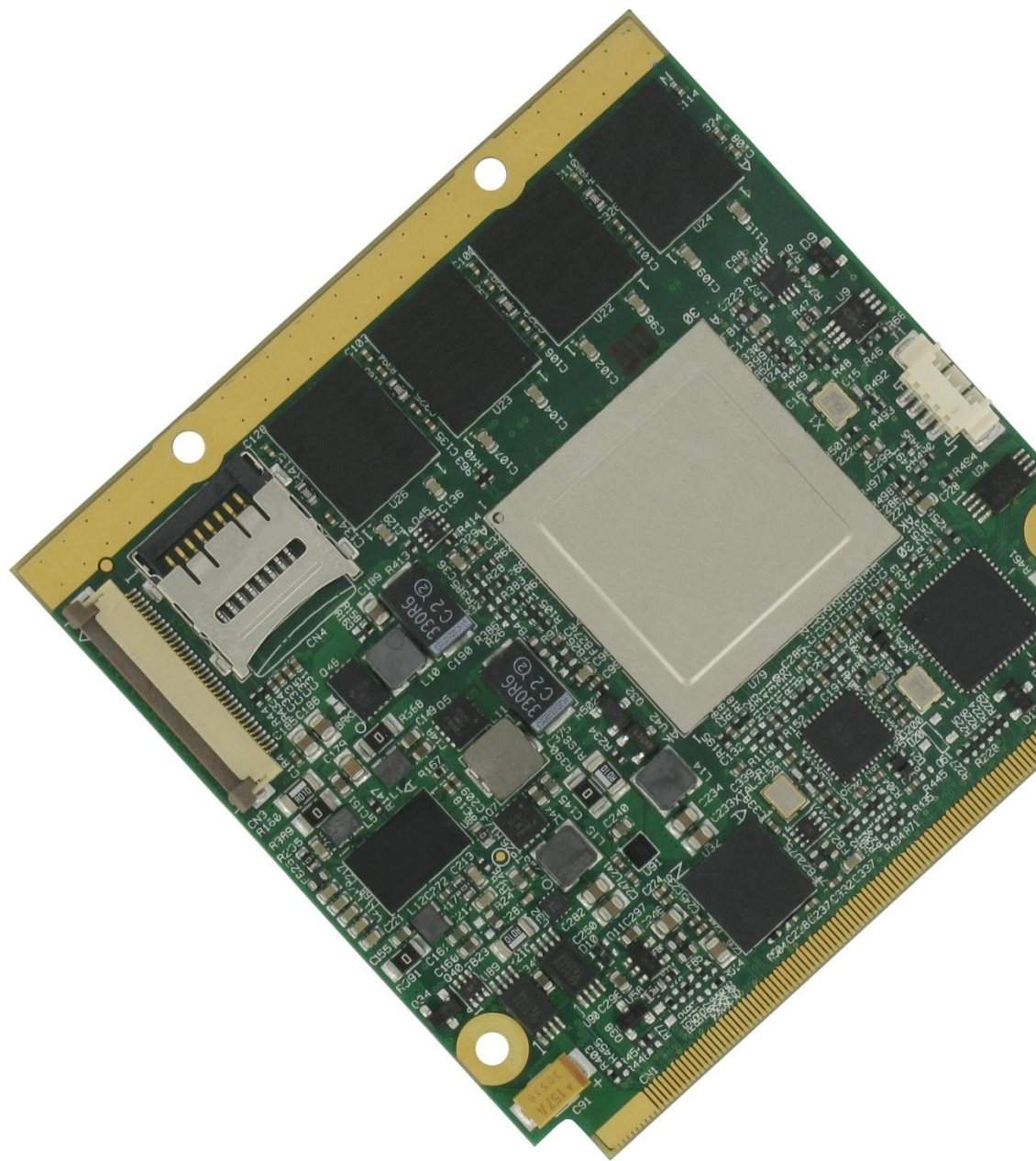

3.1 Connectors overview

According to Qseven[®] specifications, all interfaces to the board are available through a single card edge connector. In addition, a camera FFC/FPC connector card slot is present on the side of the board to take advantage of the integrated ISP (Image Signal Processing) subsystem of T30 processor.

Top side

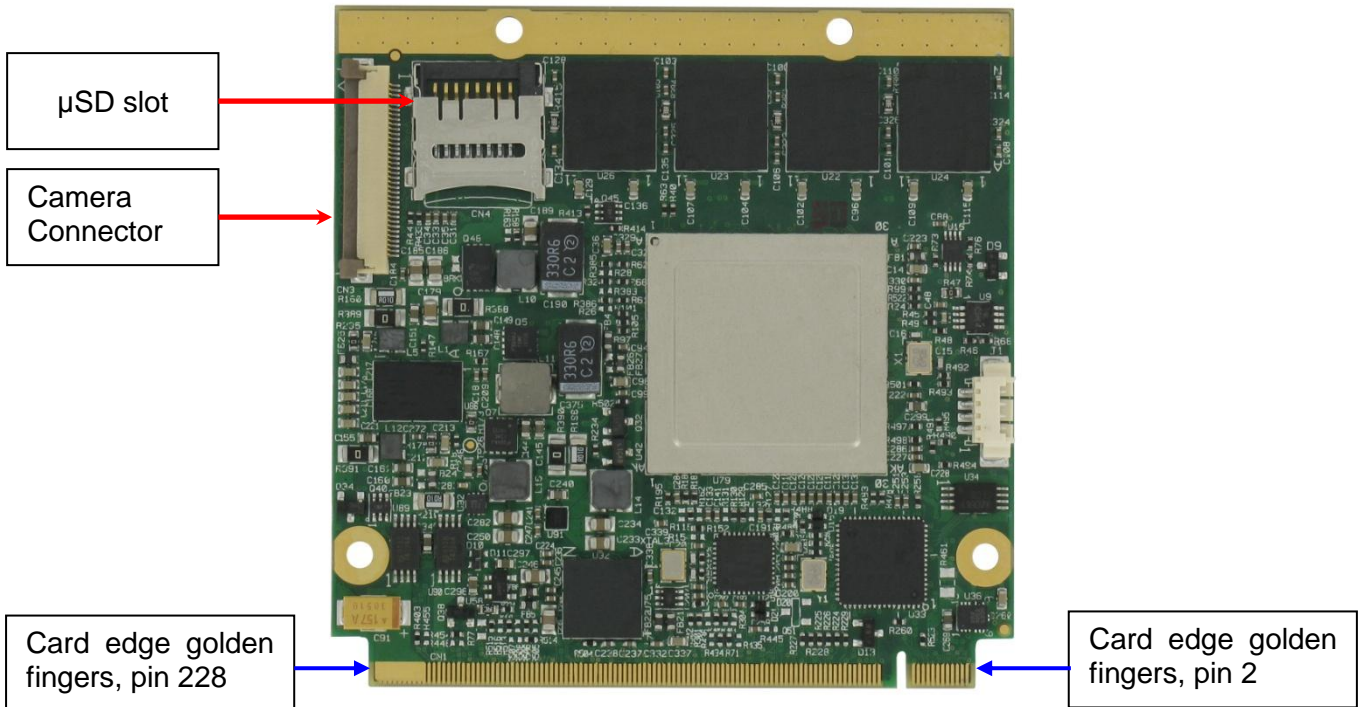

Bottom side

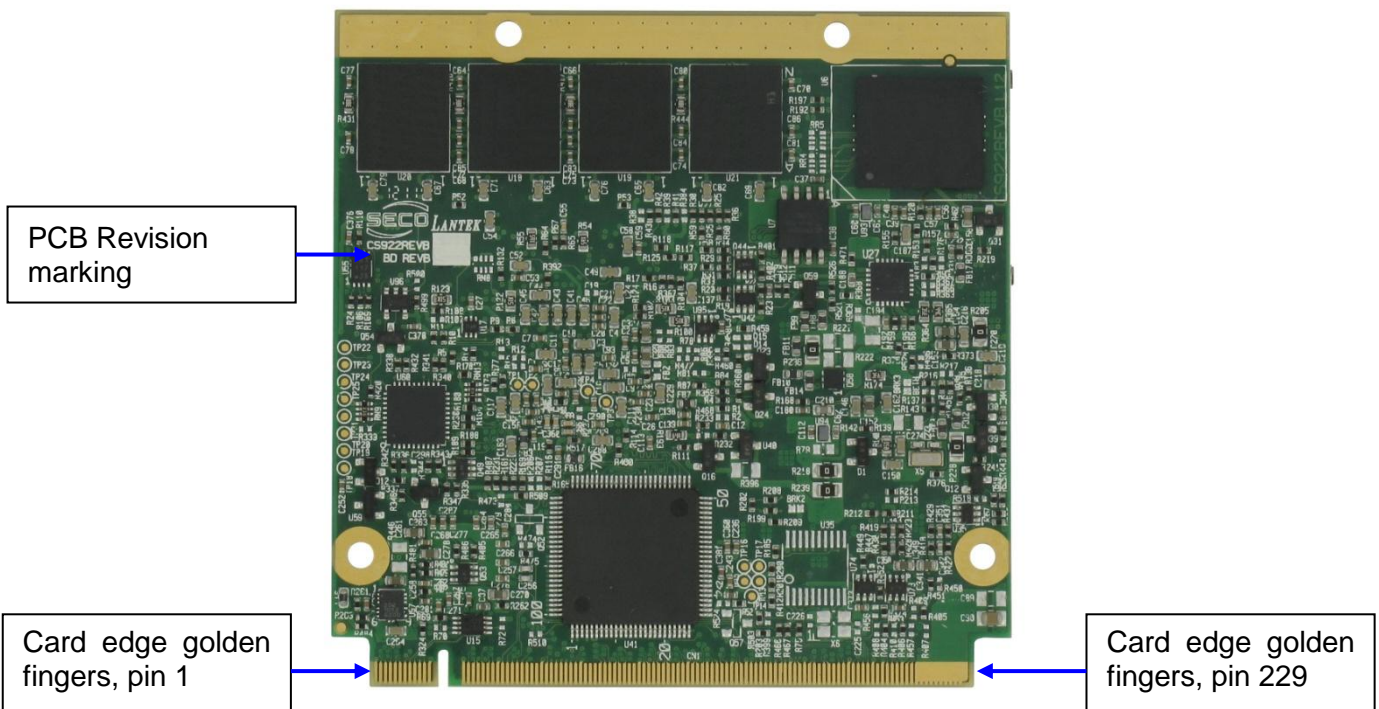

3.2 Connectors description

3.2.1 FFC/FPC Camera Interface

NVIDIA® T30 Processor includes an Image Processing Subsystem, that can be used for video applications, like video-preview, video recording and frame grabbing.

The access to the 12-bit video input port comes through an FFC/FPC connector, type HIROSE p/n FH12A-36-S-0.5SH(55).

On the same connector, it is also reported the access to the dedicated MIPI CSI (Camera Serial Interface) Port.

CAM_Dx signals are at +3.3V_{DC} electrical level, while CSI_xx differential signals are at +1.2V_{DC} electrical level.

CAMERA CONNECTOR – CN3			
Pin	Signal	Pin	Signal
1	CAM_XCLK_A	19	CAM_D1
2	GND	20	CS_D1BN
3	CAM_MCLK	21	CS_D1BP
4	GND	22	CAM_PWR_ON
5	CAM_PCLK	23	CAM_I2C_CLK
6	CAM_VS	24	CAM_I2C_SDA
7	CAM_HS	25	CAM_RESETB
8	---	26	GND
9	GND	27	CSI_CLKBN
10	CAM_D2	28	CSI_CLKBP
11	CAM_D3	29	+3.3V _{DC}
12	CAM_D4	30	+3.3V _{DC}
13	CAM_D5	31	CSI_CLK_AN
14	CAM_D6	32	CSI_CLK_AP
15	CAM_D7	33	CSI_D1_AN
16	CAM_D8	34	CSI_D1_AP
17	CAM_D9	35	CSI_D2_AN
18	CAM_D0	36	CSI_D2_AP

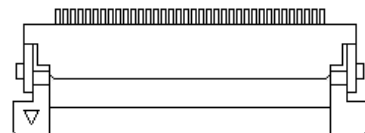

3.2.2 MicroSD Card Slot

On Quadmo747-X/T30 board, NVIDIA® Tegra T30 processor offer many different SDIO interfaces, that can be used independently one from the other to implement different mass storages (internal eMMC, internal SD Card, external SDI/O interface)

SDI/O port #3 is carried to a microSD card slot, soldered on board on top side.

The connector is a standard microSD slot, type TOWNES TKS0192003 or equivalent.

PLEASE BE AWARE THAT ON REV.B OF THE PCB THE μSD CARD SLOT IS NOT WORKING.

SD/MMC Card Connector – CN4	
Pin	Signal
1	SD3_DATA_2
2	SD3_DATA_3
3	SD3_Command
4	SD3_Power(+3.3V, software enabled)
5	SD3_Clock
6	GND
7	SD3_DATA_0
8	SD3_DATA_1

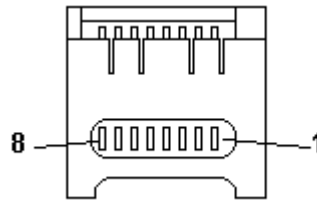

3.2.3 Qseven® Connector

According to Qseven® specifications, all interface signals are reported on the card edge connector, which is a 230-pin Card Edge that can be inserted into standard MXM connectors, as described in Qseven® specifications

Not all signals contemplated in Qseven® standard are implemented on MXM connector, due to the functionalities really implemented on Quadmo747-X/T30 CPU module. Therefore, please refer to the following table for a list of effective signals reported on MXM connector.

For accurate signals description, please consult Qseven® specifications.

Some signals are optional, depending on Quadmo747-X/T30 module configuration. See the description at the end of this document for the list of signals that are not always present (they are also highlighted in light blue in the following table, however). For further details and explanations on these signals, see Qseven® specifications.

NOTE: Even pins are available on top side of CPU board; odd pins are available on bottom side of CPU board. Please refer to board photos.

Card Edge Golden Fingers - CN1			
Pin	Signal	Pin	Signal
1	GND	2	GND
3	GBE_MDI3-	4	GBE_MDI2-
5	GBE_MDI3+	6	GBE_MDI2+
7	GBE_LINK100#	8	GBE_LINK1000#
9	GBE_MDI1-	10	GBE_MDI0-
11	GBE_MDI1+	12	GBE_MDI0+
13	GBE_LINK#	14	GBE_ACT#
15	GBE_CTREF	16	SUS_S5#
17	WAKE#	18	SUS_S3#
19	SUS_STAT#	20	PWR_BTN#
21	SLP_BTN#	22	LID_BTN#
23	GND	24	GND
25	GND	26	PWGIN
27	BATLOW#	28	RSTBTN#
29	SATA0_TX+	30	---

31	SATA0_TX-	32	---
33	SATA_ACT#	34	GND
35	SATA0_RX+	36	---
37	SATA0_RX-	38	---
39	GND	40	GND
41	BOOT_ALT#	42	SDIO_CLK#
43	SDIO_CD#	44	---
45	SDIO_CMD	46	SDIO_WP
47	SDIO_PWR#	48	SDIO_DAT1
49	SDIO_DAT0	50	SDIO_DAT3
51	SDIO_DAT2	52	---
53	---	54	---
55	---	56	---
57	GND	58	GND
59	HDA_SYNC	60	SMB_CLK
61	HDA_RST#	62	SMB_DAT
63	HDA_BITCLK	64	SMB_ALERT#
65	HDA_SDI	66	I2C_CLK
67	HDA_SDO	68	I2C_DAT
69	THRM#	70	WDTRIG#
71	THRMTRIP#	72	WDOUT
73	GND	74	GND
75	---	76	---
77	---	78	---
79	---	80	USB_4_5_OC#
81	USB_P5-	82	USB_P4-
83	USB_P5+	84	USB_P4+
85	USB_2_3_OC#	86	USB_0_1_OC#
87	USB_P3-	88	USB_P2-
89	USB_P3+	90	USB_P2+
91	USB_CC	92	USB_ID
93	USB_P1-	94	USB_P0-
95	USB_P1+	96	USB_P0+
97	GND	98	GND
99	LVDS_A0+	100	LVDS_B0+
101	LVDS_A0-	102	LVDS_B0-
103	LVDS_A1+	104	LVDS_B1+
105	LVDS_A1-	106	LVDS_B1-
107	LVDS_A2+	108	LVDS_B2+
109	LVDS_A2-	110	LVDS_B2-
111	LVDS_PPEN	112	LVDS_BLEN

113	LVDS_A3+	114	LVDS_B_CLK+
115	LVDS_A3-	116	LVDS_B_CLK-
117	GND	118	GND
119	LVDS_A_CLK+	120	LVDS_B3+
121	LVDS_A_CLK-	122	LVDS_B3-
123	LVDS_BLT_CTRL	124	ONE_WIRE
125	CAM_I2C_SDA	126	---
127	CAM_I2C_CLK	128	---
129	CAN_TX	130	CAN_RX
131	TMDS_CLK+	132	DSI_CLK0_D+
133	TMDS_CLK-	134	DSI_CLK0_D-
135	GND	136	GND
137	TMDS_LANE1+	138	DSI_D0_D+
139	TMDS_LANE1-	140	DSI_D0_D-
141	GND	142	GND
143	TMDS_LANE0+	144	DSI_D1_D+
145	TMDS_LANE0-	146	DSI_D1_D-
147	GND	148	GND
149	TMDS_LANE2+	150	HDMI_CTRL_DAT
151	TMDS_LANE2-	152	HDMI_CTRL_CLK
153	HDMI_HPD#	154	---
155	PCIE_CLK_REF+	156	PCIE_WAKE#
157	PCIE_CLK_REF-	158	PCIE_RST#
159	GND	160	GND
161	PCIE3_TX+	162	PCIE3_RX+
163	PCIE3_TX-	164	PCIE3_RX-
165	GND	166	GND
167	PCIE2_TX+	168	PCIE2_RX+
169	PCIE2_TX-	170	PCIE2_RX-
171	EXCD0_PERST#	172	EXCD1_PERST#
173	PCIE1_TX+	174	PCIE1_RX+
175	PCIE1_TX-	176	PCIE1_RX-
177	EXCD0_CPPE#	178	EXCD1_CPPE#
179	PCIE0_TX+	180	PCIE0_RX+
181	PCIE0_TX-	182	PCIE0_RX-
183	GND	184	GND
185	LPC_AD0	186	LPC_AD1
187	LPC_AD2	188	LPC_AD3
189	LPC_CLK	190	LPC_FRAME#
191	SERIRQ	192	---
193	Vcc_RTC	194	GP_PWM_OUT2

195	FAN_TACHOIN	196	FAN_PWMOUT
197	GND	198	GND
199	SPI_MOSI	200	SPI_CS0#
201	SPI_MISO	202	SPI_CS1#
203	SPI_SCK	204	MFG_NC4
205	+5V _{SB}	206	+5V _{SB}
207	MFG_NC0 (JTAG_TCK)	208	MFG_NC2
209	MFG_NC1	210	MFG_NC3 (JTAG_TMS)
211	+Vcc	212	+Vcc
213	+Vcc	214	+Vcc
215	+Vcc	216	+Vcc
217	+Vcc	218	+Vcc
219	+Vcc	220	+Vcc
221	+Vcc	222	+Vcc
223	+Vcc	224	+Vcc
225	+Vcc	226	+Vcc
227	+Vcc	228	+Vcc
229	+Vcc	230	+Vcc

3.2.4 SECOQseven philosophy's specific signals.

According to SECOQseven philosophy, on Quadmo747-X/T30 finger connector there are some signals that are not implemented in Qseven[®] Specifications rel.1.20, but that don't interfere with standard Carrier Boards (i.e., Carrier Boards not designed according to SECOQseven philosophy's Design Guide).

One-Wire Signal

Pin 124: ONE_WIRE: One-Wire protocol data line

One-Wire is a communication protocol, intended for low speed serial communications, which is widely used for simple, cheap devices like sensors and so on. All communications come through a unique line, which carries both power and signals.

This interface has been carried out on Qseven[®] golden finger, on pin 124, that is a pin defined as "Reserved" by Qseven[®] specifications Rel. 1.20 (and previous releases). Carrier Boards that leave pin 124 not connected can be used without problem also with Quadmo747-X/T30 board.

3.2.5 Quadmo747-X/T30 errata

On rev. B of the PCB of Quadmo747-X/t30 board, signals related to LVDS second channel clock and most significant pair are switched.

More exactly, LVDS_B_CLK+ / - signals are switched with signals LVDS_B3+ / -.

This inversion will be corrected in the next revision of the PCB. In the meanwhile, if you are using dual channel LVDS displays, please take care of this switching in your LVDS cable, you simply need to invert between them the two differential pairs in the cable.

These signals are written in red in the table above (pins 114, 116, 120 and 122)

3.2.6 Optional signals.

The following signals will be present only in case your Quadmo747-X/T30 Module has the CAN controller mounted:

CAN Interface Signals

Pin 129:CAN_TX: CAN Controller Transmit Line

Pin 130:CAN_RX: CAN Controller Receive Line

3.2.7 JTAG signals.

According to Qseven[®] Standard specifications, rel. 1.20, on pin designed as MFG_NCx are carried the JTAG signal necessary to program Quadmo747-X/T30 internal FPGA.

Pins 208 and 209 are multiplexed, according to the above mentioned specifications, with NVIDIA[®] T30 Internal UART #3 signals TX and RX.

Selection between JTAG and UART#3 signals is made by driving the MFG_NC4 signal carried on pin 20, with the following meaning:

MFG_NC4 signal level	Pin 208 signal:	Pin 209 signal:
LOW	UART_2_TX	UART_2_RX
HIGH	JTAG_TDI	JTAG_TDO

In case MFG_NC4 signal is not driven externally, then an internal pull-up makes available JTAG_TDI and JTAG_TDO signals on pin 208 and 209.



www.secoqseven.com