

Description

Special mounting supports have been designed for the integration of power supplies into switch boards, control panels, printed circuit boards, etc., using adapters for chassis-, DIN-rail, or PCB mounting.

The 19-inch cassette style DC-DC and AC-DC converters can also be chassis-mounted with frontal access by means of a special *Chassis Mounting Plate*, attached to the converters.

The *Universal Mounting Bracket* also fits to most of these cassette type converters, allowing for either vertical-chassis or DIN-rail mounting.

A *Bracket Kit*, consisting of a PCB with screw-terminal connectors and a brackets suitable for either chassis or DIN-

rail mounting, is available either for PCB mountable PSR and PSA Switching Regulators with option "Y" pins or for small DC-DC converters up to 15 Watt.

For isolation of the PCB-mountable converters from a double-sided PCB, the use of *Isolation Pads* is recommended, as described below.

RoHS-compliant products are available on request.

Note: All dimensions are in mm, unless otherwise specified.

Table of Contents

	Page		Page
Description	1	DIN-Rail and Chassis-Mounting Brackets	6
Chassis Mounting Plates	2	Isolation Pads for PCB Mounting	11
Universal Mounting Brackets	4	PCB-Tags for PCB Mounting	11

Chassis Mounting Plates

For chassis mounting of 19" cassette-style converters, where only frontal access to the mounting screws is given, special chassis mounting plate adapters are available according to the following table and figures 1 to 3.

Table 1: Mounting Plate survey

Case size	Converter series	Model type Item no.	Delivery content
K02	K ¹ , PSK ¹	Mounting plate K02 HZZ01213	Mounting plate, 4 countersunk screws
S02	S ¹ , PSS ¹ , R ¹		
Q01	Q	Mounting plate Q HZZ01215	
Q03	LPC		
Q04	P		
Q01	Q	Mounting plate M HZZ01210	Mounting plate, 4 countersunk screws, 4 washers
Q03	LPC		
Q04	P		
M02	M		
H02	H		

¹ with Option B1

Note: The mounting plate K02 fits to K, S, PSK, or PSS converters with opt. B1. However, it is possible to order these converters directly with option B. Such converters exhibit the same mounting plate as shown in fig. 1.

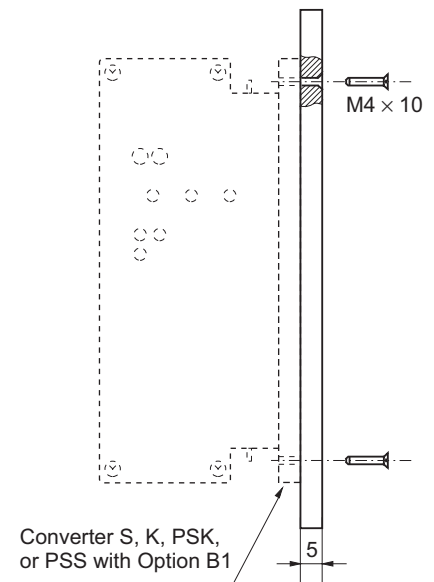
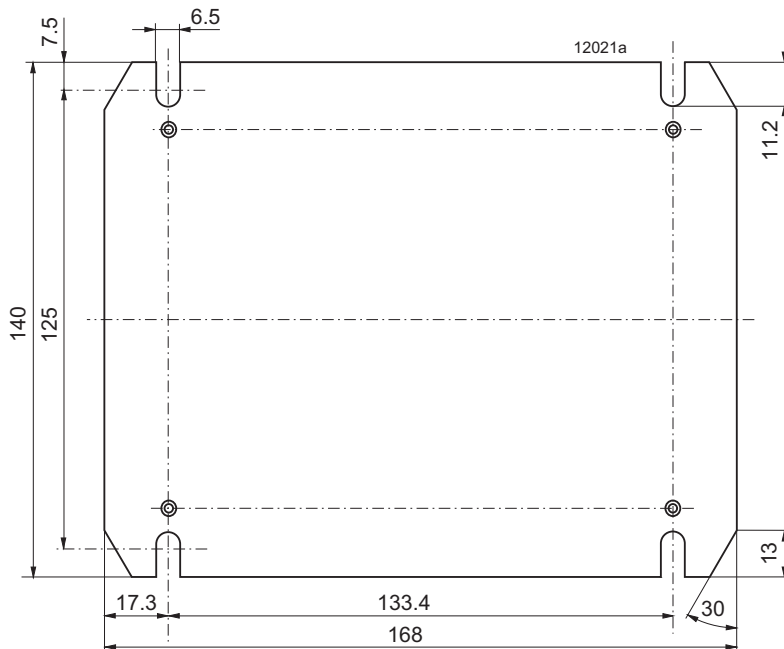

Fig. 1
Mounting plate K02
Aluminium, black finish

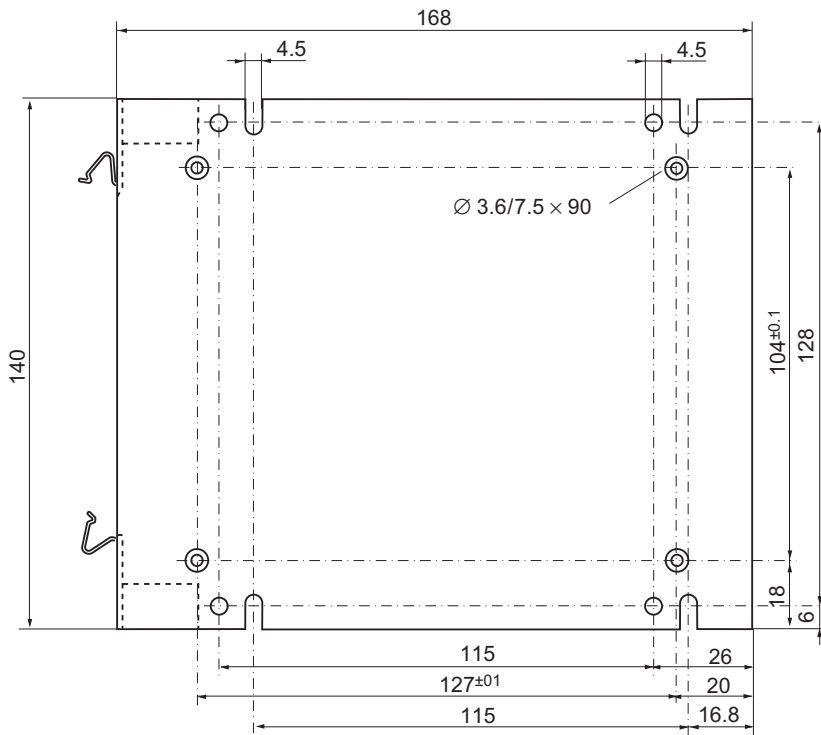

Fig. 2a
Mounting plate Q with integrated connector retention facility
using the Retention Clip [HZZ01209]
Aluminium, black finish

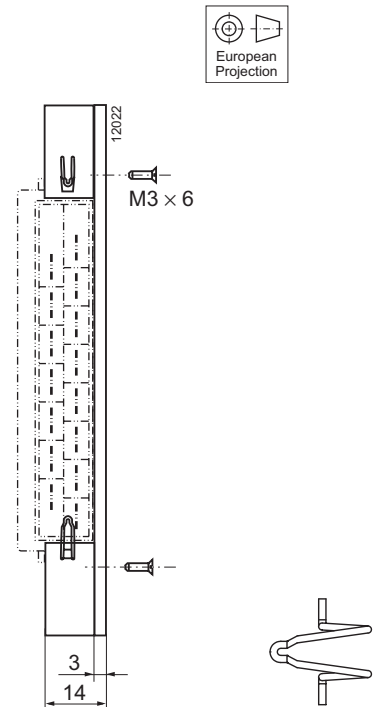

Fig. 2b
Retention Clip
[HZZ01209]

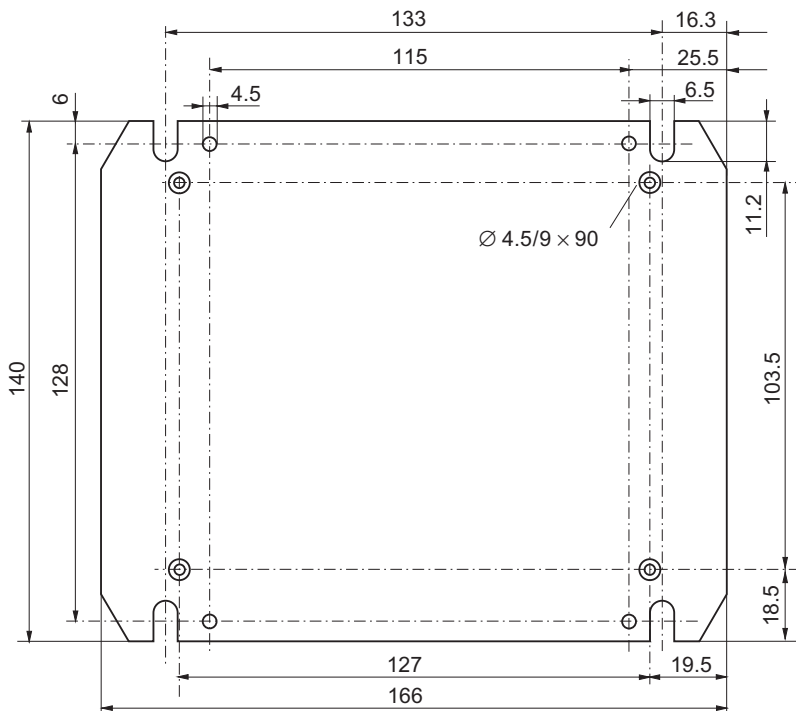
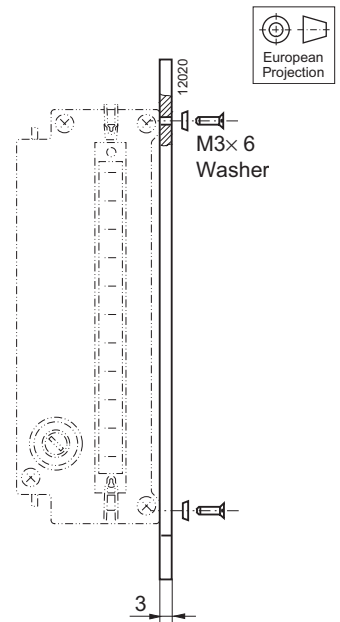

Fig. 3
Mounting plate M
Aluminium, black finish



Universal Mounting Brackets
(DIN- and Chassis Mounting)

Series H, M, Q, P, LPC, PSL

A special universal mounting bracket has been designed for vertical or upright chassis and DIN-rail mounting of the 19" cassette style converters shown in table 2.

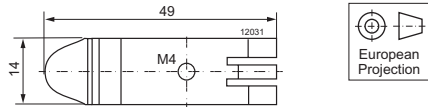

Fig. 4
DIN-rail clamp
Steel, galvanized

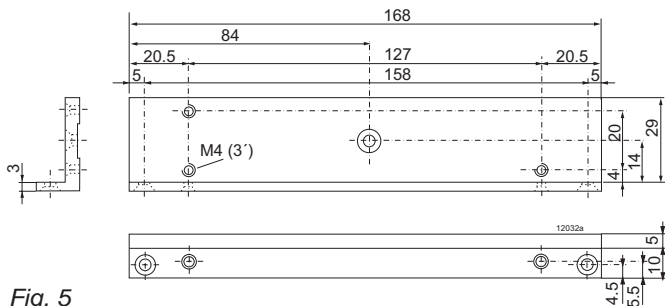

Fig. 5
Universal mounting bracket UMB-LHMQ
Aluminum, untreated

Series W and X

Chassis mounting brackets UMB-W are available; see table 2 and fig. 6.

DIN-rail mounting is possible with the built-in snap fit devices. For heavy-duty railway applications, 2 or better all 4 fixing brackets DMB-EWG should be fitted; see fig. 8.

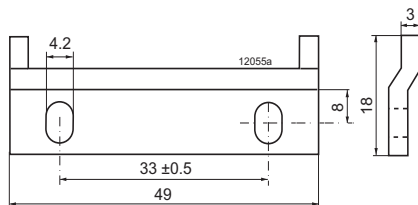

Fig. 6
Universal mounting bracket UMB-W

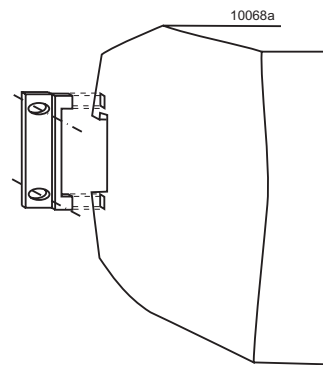

Fig. 7
W unit with chassis-mounting brackets

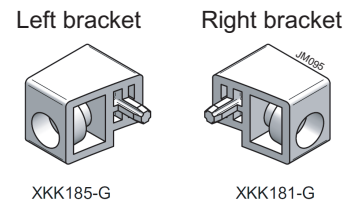

Fig. 8
Additional fixing brackets for railway application

Table 2: Universal mounting bracket survey

Converter case size	Converter series	Bracket item no.	Delivery content
L04 H02, M02 Q01, Q03, Q04	PSL H, M Q, LPC, P	UMB-LHMQ HZZ00610	Alu-profile (fig. 5), 2 screws and a DIN-rail clamp (fig. 4) with screw
W01, X01	W, X	UMB-W HZZ00618	2 clamps (fig. 6), 4 countersunk screws M4, washers, and spring washers
		DMB-EWG HZZ00624	DIN-rail clamp left and right (fig. 9), 2 screws M4, 2 washers, 2 ribbed-lock washers

DMB-K/S, DMB-MHQ

By means of these DMB mounting kits, the S, K, PSS, PSK (DMB-K/S) and the M, H, Q, LPC, P (DMB-MHQ) converters can be fastened onto a DIN-rail. The kit consists of two aluminum brackets to be mounted on each side of the converter, including a clamp. The DMB-K/S kit contains two different sets of screws for the adaptation of the brackets either to S/PSS or K/PSK converter types. The design of the kit is made such that the fixture is very tight, and as a result the assembly can also be used for mobile applications.

Table 3: Mounting bracket survey

Case size	Converter series	Type item no.
S01	PSS	DMB-K/S
S02	S, R	HZZ00615
K01	PSK	
K02	K	
M02	M	DMB-MHQ
H02	H	HZZ00619
Q01	Q ¹	
Q03	LPC ¹	
Q04	P ¹	

¹ Not together with screw-style connectors STV-H15-FSR [HZZ00107]

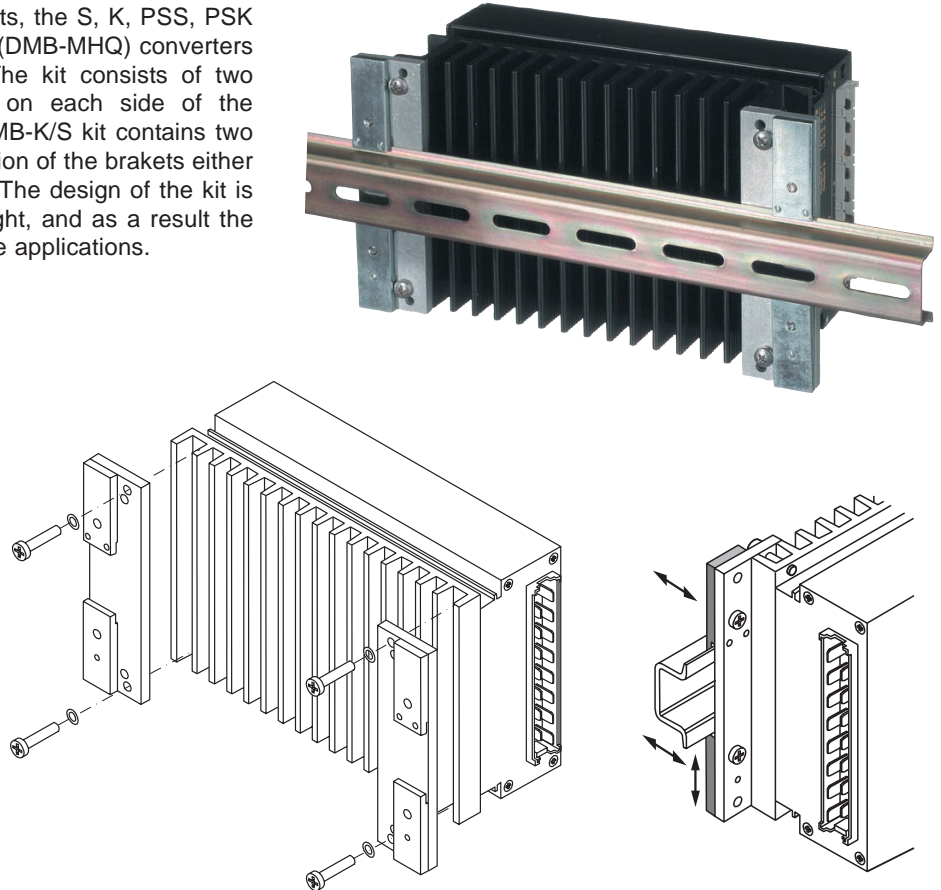

Fig. 9
Schematic view: Assembly of DMB-K/S

CMB-S

This mounting kit allows for chassis mounting of the S and PSS Series converters, if access is only possible from the front of the chassis.

Note: If space conditions are very tight, option B1 or B can be used instead of the heat sink. Refer to the data sheets of the respective converters.

This kit uses parts of the DMB-K/S kit, since it consists of the same two brackets but without the clamps and fitted the other way round on the heat sink.

Table 4: Mounting bracket survey

Case size	Converter series	Type Part no.
S01	PSS	CMB-S
S02	S, R	HZZ00616



DIN-Rail and Chassis-Mounting Brackets

PCB mounting as well as cassette style converters can be chassis- or DIN-Rail mounted by means of mounting bracket adapters. For selection and part numbers refer to table 5 !

Note: Customized adapters for other case sizes are available upon request.

Each part number gives a direct indication of the kind of mounting, the type of converter, i.e. the case size, or the output power as well as the possible pin-out and the options according to the relevant converter data. The adapters are divided into two mechanical types: CMB and DMB.

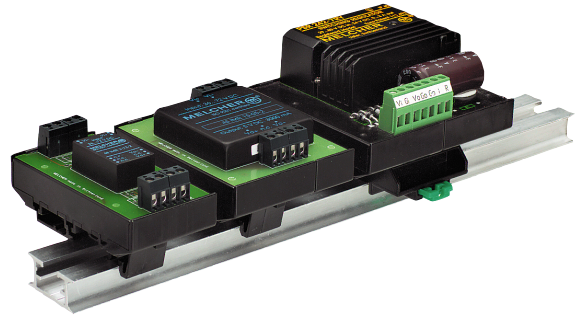

Table 5: Mounting Bracket survey

A1 [mm]	A2 [mm]	Converter case size	Converter series	Chassis-mounting Part no.	DIN-mounting Part no.	Delivery content
95.0	90.0	A01	PSR, PSA ($V_{i\ max} = 40, 60, 80\ V$)	CMB A01-iRY/80 HZZ00607	DMBA01-iRY/80 HZZ00606	PCB, screw terminal blocks, 4 diodes, capacitor C1 and C- or D-bracket with screws
			PSA ($V_{i\ max} = 144\ V$)	CMB A01-iRY/144 HZZ00609	DMBA01-iRY/144 HZZ00608	
50.0	45.0	DIL 24	IMX4 with Option K IMS6 with Option K	CMB3W-123 HZZ00604	DMB3W-123 HZZ00602	
72.5	67.5	1" x 2"	IMX7, IMS7 IML10 ¹	CMBIMS/X7 HZZ00617	DMBIMS/X7 HZZ00613	See Basic Kit C/DMBIMX/S7

¹ Obsolete model

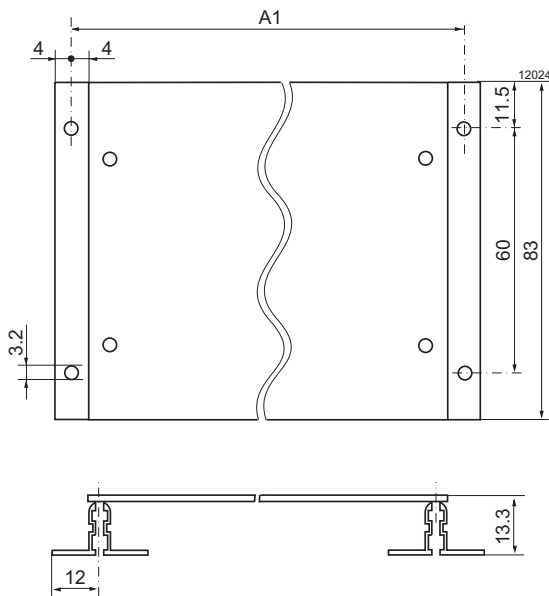

Fig. 10
CMB chassis mounting bracket dimensions
Bracket: Aluminum, black finish

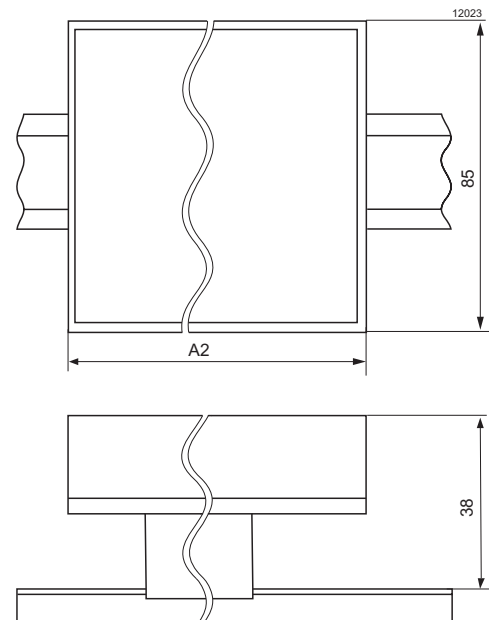

Fig. 11
DMB DIN-rail mounting bracket dimensions
Bracket: Polycarbonate, black

CMB: Chassis Mounting Bracket

The kit consists of a PCB for the converter, a set of screw terminals allowing for easy electrical connection and two aluminium profiles, attached to the PCB by means of four screws, which serve as the chassis mounting bracket. Four different versions according to table 2 are available.

Details on the layout of the PCBs and diagrams are given in the description below.

DMB: DIN-Rail Mounting Bracket

The DMB kit differs from the CMB version by a bracket suited for DIN-rail mounting. The black plastic body of the bracket holds the PCB by means of a snap-in device. Four different versions according to table 5 are available.

Details on the layout of the PCB's and diagrams are given in the description below.

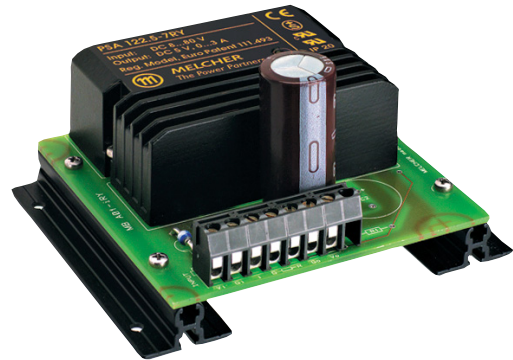

C/DMBA01-... Electrical Description

This bracket is designed for non-isolated switching regulators of the PSR and PSA Series in the A01 case size, equipped with option Y. Technical details and further information, e.g. max. input voltage etc., are described in the PSR/PSA data sheet. The use of the optional inhibit- and R-function (external output voltage adjustment with R1) is possible, and the device can be driven either from a DC-source or from a transformer secondary voltage.

- DC-input: Consider the forward voltage drop across the rectifier diodes (also providing reverse polarity protection). Capacitor C1 compensates for the negative input impedance of the converter in case of long connection wires.
- AC-input: The recommended transformer secondary voltage is 48 VAC for PSR/PSA (with $V_{i\max} = 80\text{ V}$) and 72 VAC for PSA (with $V_{i\max} = 144\text{ V}$)

Exception: Input voltage for PSA55 is 20 VAC.

Note: PSA55 and PSR362 require an additional capacitor (C2) of at least 470 μF .

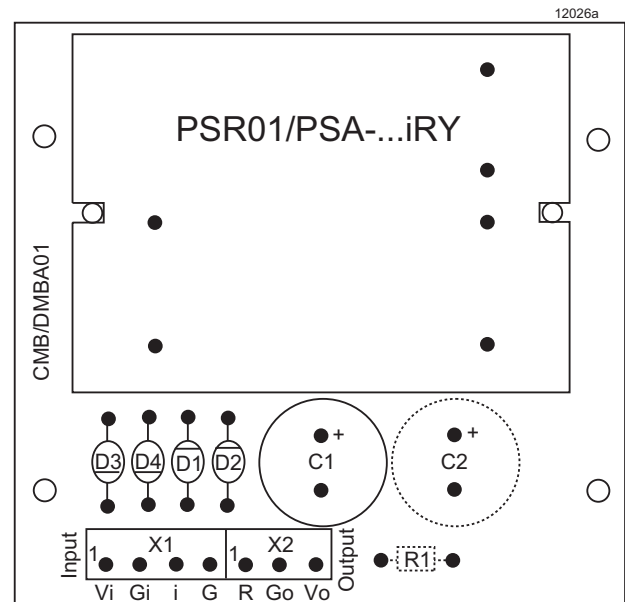

Fig. 13
C/DMBA01- .. PCB layout

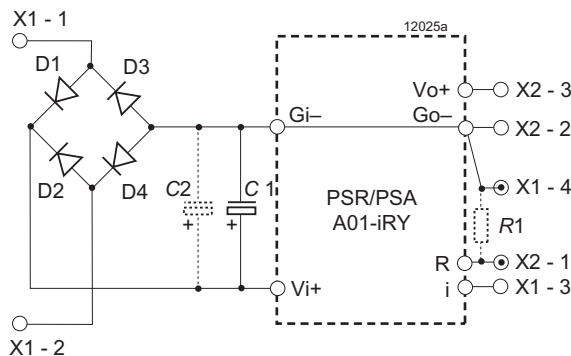
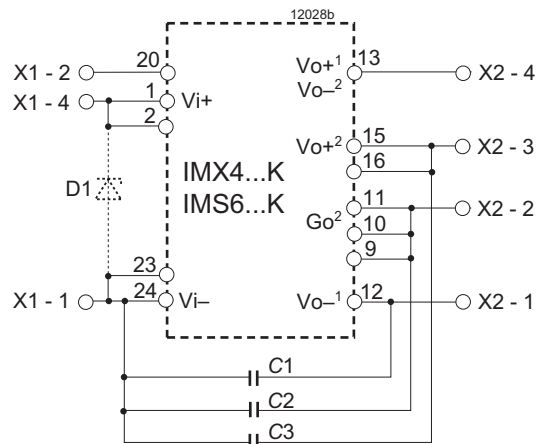

Fig. 12
C/DMBA01-... circuit diagram

C/DMB3W-123 Electrical Description

This bracket is designed for galvanically isolated DC-DC converters of the IMX4 and IMS6 Series (both with option K) in DIL 24 cases with one or two output voltages. The pin configuration of the converter groups single, double, and dual, and all technical converter details are described in the data sheets.

Depending on the application input transient protection may be incorporated (e.g. an appropriate Transzorb diode D1) .



- 1 Single-output models
- 2 Double-output models

Fig. 14
C/DMB3W-123 circuit diagram

- Four nuts M 2.5
- PCB
- Three 2-pole terminal blocks (2 × for X1 terminal, 1 × for X3 terminal)
- One 3-pole terminal block for X2 terminal
- Three wire jumpers 5.08 mm (positions B1, B4, B5)
- One wire jumper 10.16 mm (position D1)
- Six wire jumpers 6.8 mm (positions L2, L4, L6)
- Circuit diagram no. YSK25300 S3 01

Basic Kit DMBIMX/S7

For use with 1"×2" DC-DC converter types: IML10, IMS7 and IMX7

The basic kit contains the following:

- DIN-mounting support for 35 mm DIN-rail systems
- PCB
- Three 2-pole terminal blocks (2 × for X1 terminal, 1 × for X3 terminal)
- One 3-pole terminal block for X2 terminal
- Three wire jumpers 5.08 mm (positions B1, B4, B5)
- One wire jumper 10.16 mm (position D1)
- Six wire jumpers 6.8 mm (positions L2, L4, L6)
- Circuit diagram no. YSK25300 S3 01

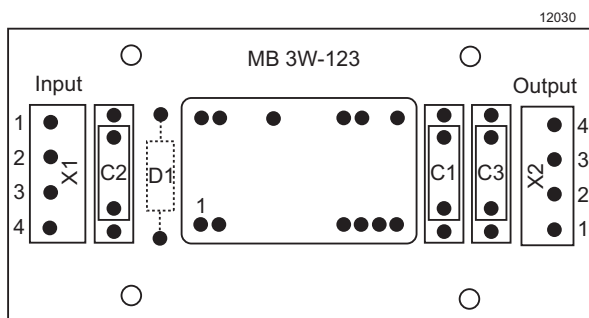

Fig. 15
C/DMB3W-123 print layout

Basic Kit CMBIMX/S7

For use with 1" × 2" DC-DC converter types: IMX7, IMS7, IML10

Part no. HZZ00617

The basic kit contains the following:

- Two mounting rails, 83 mm
- Four screws M 2.5 × 6

Mounting Instructions for Basic Kit

Single-output models IMX7, IMS7, IML10:

- Solder the wire jumpers into positions as below:
 1. D1 (10.16 mm)
 2. B1 (5.08 mm), inhibit.

Note: This jumper should be fitted, if the inhibit is not actively used. An open inhibit disables the converter.

3. L2-A and L2-B, L6-A and L6-B (6.8 mm)
 4. L4-A and L4-B (6.8 mm), only necessary, if the R-input is used.
- Solder terminal blocks
 5. X1: Position Vi+/ Vi–, 2-pole terminal block
 6. X1: Position i/n.c., 2-pole terminal block (only necessary in the case of remote inhibit)
 7. X3: Position Vo+/ Vo–, 2-pole terminal block
 8. X2: Position n.c., R, Vo–, 3-pole terminal block only necessary in the case of V_o adjustment by e.g. an external voltage source)
 - Solder the selected DC-DC converter
 - Mount PCB onto rails by using the 4 screws and nuts or snap PCB onto the DIN mounting support.
 - Perform function test

Double-output models IMX7, IMS7, IML10:

- Solder the wire jumpers into positions as below:
 1. D1 (10.16 mm)
 2. B1 (5.08 mm), inhibit

Note: This jumper should be fitted, if the inhibit is not actively used. An open inhibit disables the converter.

3. L2-A and L2-B, L6-A and L6-B, L4-A and L4-B (all 6.8 mm)
- For applications with both outputs in parallel:
 4. Place/solder jumpers B4 and B5, (5.08 mm)
 - Solder terminal blocks
 5. X1: Position Vi+/ Vi–, 2-pole terminal block
 6. X1: Position i/R (Trim), 2-pole terminal block (only necessary in the case of remote inhibit or output voltage trimming by an external voltage source)
 7. X3: Position Vo1+/ Vo1–, 2-pole terminal block
 8. X2: Position n.c./Vo2+/Vo2–, 3-pole terminal block
 - Solder the selected DC-DC converter
 - Mount PCB onto rails by using the 4 screws and nuts or snap PCB onto the DIN mounting support.
 - Perform function test

Application-Specific Circuitry

The assembly C/DMBIMX/S7 offers a variety of additional external circuitries which may be implemented onto the PCB. See circuit diagram and consult the IMS/X7 data sheet.

Depending upon the application the following peripheral additions can be made:

- Reverse polarity protection by a series diode D1.
 - Improved input transient protection according to IEC/EN 61000-4-5, level 2, by chokes L1 or L2-A, L2-B (EMC version) and capacitor C1.
 - Remote inhibit.
- Note:** If the inhibit is not actively used the inhibit has to be connected to Vi– by jumper B1.
- External output voltage trimming/adjustment

Single-output models:

- a) V_o – adjustment in the range of 70/75 – 100% of $V_{o\text{ nom}}$ by resistors RX3 or RX4 or combinations of RX3/RX4.
- b) V_o – adjustment in the range of 100 – 105% of $V_{o\text{ nom}}$ by resistors RX1 or RX2 or combinations of RX1/RX2.

Double-output models:

- a) V_o – trimming by resistor R2 in the range of 100 – 105% of $V_{o\text{ nom}}$
- b) V_o – trimming in the range of 70/75 – 100% of $V_{o\text{ nom}}$ by a current diode together with a Zener diode D2 applicable for 24/48 IMS7 and 20/40IMX7 types.

- Reduced output ripple (by approx. factor 5) by using chokes L3/L5 together with electrolytic capacitors C8/C9.
- Improved electromagnetic emission EN 55022, class B, lead length to load 1 m (class A for 110IMX7 types).

This requires all capacitors and output chokes as per circuit diagram fig. 16, whereby the coupling capacitor C10 connected to Vi– via jumper B2 is foreseen for 24/48IMS/L types and 20/40/70IMX7 models.

For 110IMX7 types the coupling capacitor C11 or C12 should be used connected to Vo+ via jumper B3.

Notes:

- For single-output models or double-output models with both outputs in parallel, one filter set (L5 or L6-A/L6-B) together with C7 and C9 is sufficient.
- Wire jumpers B2 and B3 should not be mounted together onto the PCB as this would cause a short circuit.
- The coupling capacitors C10 or C11/12 should be Y2 ceramic types to maintain the outputs being SELV.
- Application specific assemblies are available on request: MK001-xxx and MK002-xxx.

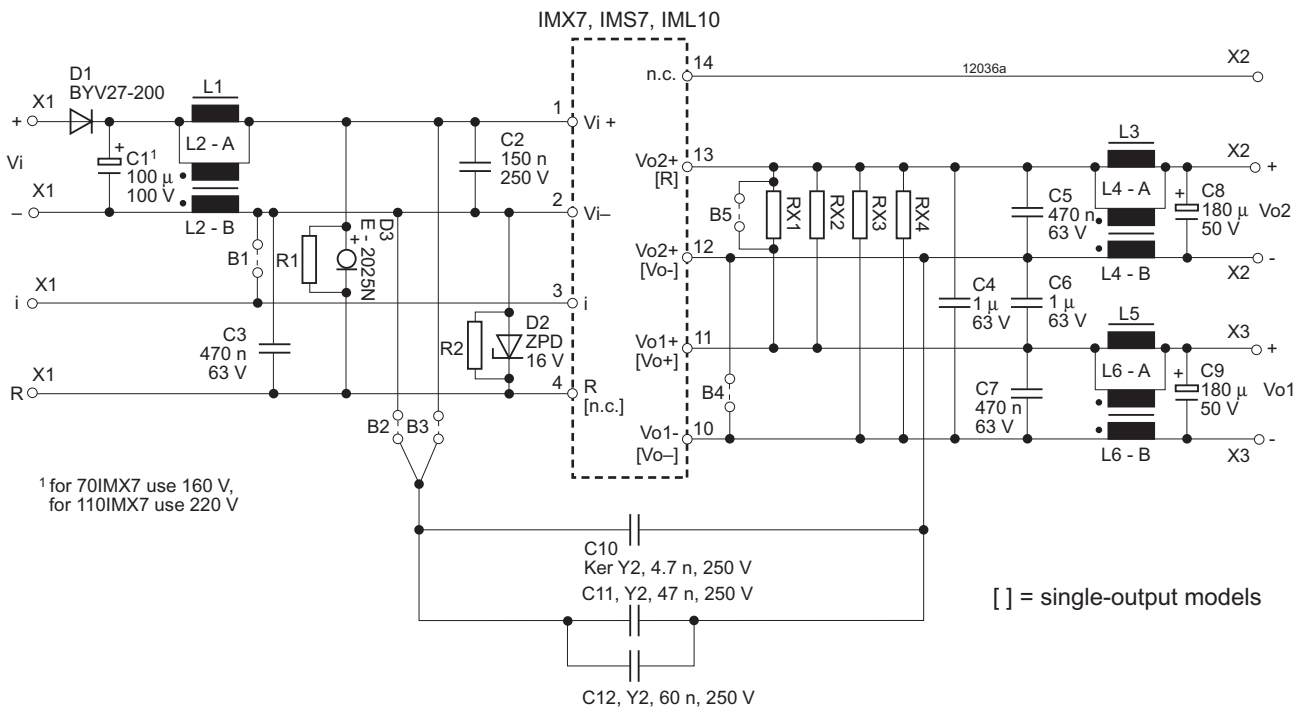

Fig. 16
C/DMB circuit diagram with IMX7, IMS7, IML10

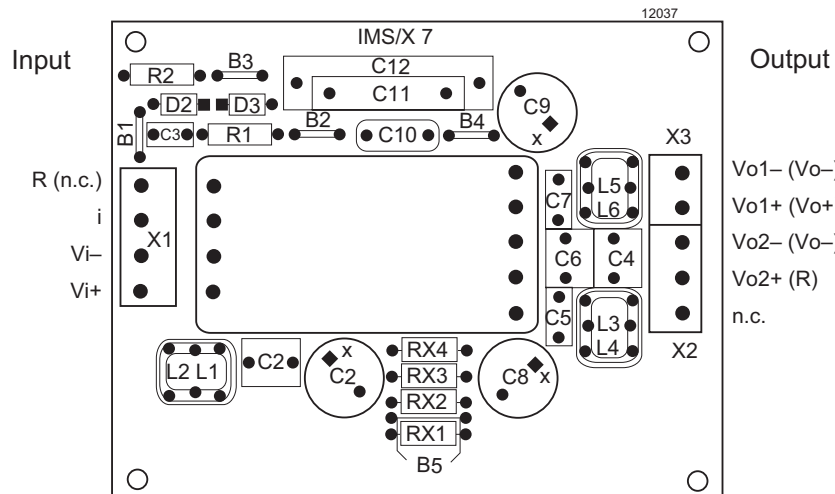

Fig. 17
C/DMB arrangement of the terminals on the PCB for IMX7, IMS7, IML10

Note: Where the pin/terminal designations for single-output models deviate from double-output models, they are shown in brackets.

Isolation Pads for PCB Mounting

In applications, where PCB mounting converters are placed on top of double sided boards, the use of Isolation Pads is recommended. These fibre pads avoid short circuits and provide excellent protection against possible damage to tracks. For selection and item numbers refer to table below.

Table 6 : Isolation Pad survey

Case size	Series	Isolation pad	Dimensions [mm]	Part no.
A01	PSA PSR	Isolation A	70 × 50 × 0.3	ISOLATIONA,A01 HZZ01203
B02	PSB	Isolation B	107 × 71 × 0.3	ISLOATIONB,B02 HZZ01205
C01	PSC	Isolation C	152 × 86 × 0.3	ISOLATIONC,C03 HZZ01206
C03	xSR20 ¹			

¹ Obsolete models

PCB-Tags for PCB Mounting

Switching Regulators in B02 or C03 cases may also be mounted directly onto PCBs. The connection between the converters' faston pins and the PCB can be easily made by means of PCB-Tags.

Delivery content: 10 pieces
Part number: LOETGABEL(10x)
HZZ10204

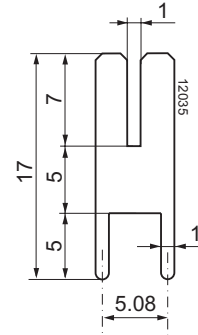

Fig. 18
PCB-Tag

NUCLEAR AND MEDICAL APPLICATIONS - Power-One products are not designed, intended for use in, or authorized for use as critical components in life support systems, equipment used in hazardous environments, or nuclear control systems without the express written consent of the respective divisional president of Power-One, Inc.

TECHNICAL REVISIONS - The appearance of products, including safety agency certifications pictured on labels, may change depending on the date manufactured. Specifications are subject to change without notice.