

Features

- RoHS lead free solder and lead solder exempted products are available
- Ultra-wide input range: 18 to 60 VDC
- Cost-effective, single board construction
- High efficiency
- Low profile
- Input-to-output isolation: 1500 VDC
- Basic Insulation
- Start-up into high capacitive load
- Low conducted and radiated EMI
- Output overcurrent protection
- Output overvoltage protection
- Input undervoltage lockout
- Overtemperature protection
- Approved to UL 60950-1/ CAN/CSA-C22.2 No. 60950-1, and TUV approved to EN 60950-1, IEC 60950-1

Applications

- Wireless base stations
- Telecommunications equipment
- LAN/WAN
- Data processing
- Industrial applications

Description

The QMS Series of converters provide a single, isolated step-down voltage (3.3, 5 or 12 VDC nominal) from a wide-input voltage range (18 – 60 VDC). The QMS is an excellent choice in applications where multiple input voltage options are required. The designer can use a single QMS converter to cover both 24Vin and 48Vin input ranges, eliminating the need to specify multiple circuit packs to handle each input range. This is particularly useful in wireless base station applications where the power plants tend to vary and could provide nominal 24 or 48 V input.

The QMS converters are highly efficient over the entire wide-input voltage range, cost-effective, and offer a low profile, industry-standard quarter-brick footprint. The standard feature set includes remote on/off, remote output voltage sensing, industry-standard output trim, input undervoltage lockout, and overtemperature shutdown with hysteresis.

| Model Selection | | | | | | |
|------------------------|--------------------------|---|---------------------------|--|--|--|
| Model | Input Voltage VDC | Input Current, Max ADC¹ | Output Voltage VDC | Output Rated Current, I_{RATED} ADC | Output Ripple/Noise, mV_{P-P}² | Typical Efficiency @ I_{RATED} & 36V_{IN} |
| QMS25DE | 18 - 60 | 6.0 | 3.3 | 25 | 50 | 90% |
| QMS14DG | 18 - 60 | 4.3 | 5.0 | 14 | 50 | 92% |
| QMS07DH | 18 - 60 | 5.0 | 12.0 | 6.75 | 120 | 92% |

This product is intended for integration into end-use equipment. All the required procedures for CE marking of end-use equipment should be followed.

¹ @ V_{IN} minimum.

² Nominal, (DC to 500 kHz)

Model numbers highlighted in yellow are not recommended for new designs.

Absolute Maximum Ratings

Stresses in excess of the absolute maximum ratings may cause performance degradation, adversely effect long-term reliability, and cause permanent damage to the converter.

| Parameter | Conditions/Description | Min | Max | Units |
|---------------------------|--|------|------|-------|
| Input Voltage | Continuous | 0 | 60 | VDC |
| | Transient Withstand (100 ms) | | 100 | VDC |
| Operating Temperature | Hot Spot Monitor Location ² (T _c) | -40 | 125 | °C |
| | Ambient | -40 | 85 | °C |
| Storage Temperature | Ambient | -40 | 125 | °C |
| ON/OFF Control Voltage | Referenced to -Vin | -0.7 | 20 | VDC |
| Output Power ¹ | QMS25DE | | 82.5 | W |
| | QMS14DG | | 70 | W |
| | QMS07DH | | 81 | W |

¹ With appropriate power derating, see Figures 37 – 42.

² See temperature probe location T_c, Figure 36. [Ref.V09 case]

Environmental and Mechanical Specifications

All specifications apply over specified input voltage, output load, and temperature range, unless otherwise noted.

| Parameter | Conditions/Description | Min | Nom | Max | Units |
|----------------------|--|--|--------|-----|-------------|
| Operating Humidity | Relative Humidity, Non-cond. | | | 95 | % |
| Storage Humidity | Relative Humidity, Non-cond. | | | 95 | % |
| Shock | (Half-sinewave, 6 ms), 3 axes | 50 | | | g |
| Sinusoidal Vibration | GR-63-CORE, Section 5.4.2 | 1 | | | g |
| Weight | | | 1.2/35 | | Oz/g |
| Water Washing | Standard process | | Yes | | |
| MTBF (Calculated) | Per Telcordia SR-332 Issue 1, (method 1, case 2, GB, 40°C) | | 1,750 | | kHrs |
| Dimensions | (Overall) | 2.28 (57.9) x 1.45 (36.8) x 0.43 (11) | | | In. (mm) |
| Markings & Labeling | Includes P/N, Logo, Date Code, Country of Manufacture | | | | |

Isolation Specifications

All specifications apply over specified input voltage, output load, and temperature range, unless otherwise noted.

| Parameter | Conditions/Description | Min | Nom | Max | Units |
|--------------------------|------------------------|-------|------|-----|-------|
| Insulation Safety Rating | | Basic | | | |
| Isolation Voltage | Input to Output | 1500 | | | VDC |
| Isolation Resistance | Input to Output | 10 | | | M Ω |
| Isolation Capacitance | Input to Output | | 4700 | | pF |

EMI & Safety Regulatory Compliance

| Safety Agency | Standard Approved To: | Marking |
|----------------------------------|--------------------------------------|-------------------|
| UL | UL60950-1 / CSA C22.2 No. 60950-1-03 | cURus |
| TUV product service | TUV EN60950-1/A11:2004 | TUV PS Baurt mark |
| CB report | IEC60950-1:2001 | N/A |
| Declaration of Conformity | DIR 73/23/EEC Low Voltage Directive | CE |
| Conducted Emissions ¹ | (with external EMI filter) | CISPR 22 class A |

¹ See figures 43, 44, 45.

Input Specifications

All specifications apply over specified input voltage, output load, and temperature range, unless otherwise noted.

| Parameter | Conditions/Description | Min | Nom | Max | Units |
|---|--|-----|-----|------|-------------------|
| Input Voltage | Continuous | 18 | | 60 | VDC |
| Turn-On Input Voltage (UVLO) ¹ | Ramping Up | 16 | 17 | 18 | VDC |
| Turn-Off Input Voltage ¹ | Ramping Down | 13 | 15 | 16.5 | VDC |
| Turn-Off Hysteresis | | 2 | | | VDC |
| Input Reflected Ripple Current | @ I _{RATED} , 12μH source inductance BW=20MHz ² | | 10 | 72 | mA _{p-p} |
| No-load Input Current | 18VDC ≤ Vin ≤ 60VDCc | | 90 | 150 | mA |
| No-load Power Dissipation | Vin = 36VDC | | | 5 | W |
| Disabled Input Current | 18VDC ≤ Vin ≤ 60VDC | | 25 | 50 | mA |
| Input Capacitance (internal) | | | | 1.4 | μF |
| Minimum Input Capacitance (external) | (ESR < 0.7 Ω) | 100 | | | μF |
| Inrush Transient | | | | 0.1 | A ² s |

¹ see Figure 2

² Vin = 36Vin, see Figures 1 and 47

Output Specifications

All specifications apply over specified input voltage, output load, and @ 40 °C ambient temperature, unless otherwise noted.

QMS25DE: 3.3V / 25A

| Parameter | Conditions/Description | Min | Nom | Max | Units | |
|---|---|----------------|-------|---------|-------------------|----|
| Output Voltage (Set-point) | Vin = 36V, Io = 25A | 3.25 | 3.30 | 3.35 | VDC | |
| Line Regulation | Vi = 18V to 60V, Io = 50% Io,max | | | 10 | mV | |
| | | | | 0.3 | % | |
| Load Regulation | Vin = 36V, Io,min to Io,max | | | 25 | mV | |
| | | | | 0.75 | % | |
| Temperature Coefficient | -40 °C ≤ T _{AMB} ≤ +85 °C | | | 0.02 | %/°C | |
| Total Error Band | (Line, Load, Temperature, Ripple, Life) | 3.12 | | 3.48 | VDC | |
| | | | | +/- 5.5 | % | |
| Output Power ¹ | w/ proper thermal derating | | | 82.5 | W | |
| Output Current ¹ | w/ proper thermal derating | 0 | | 25 | A | |
| Output Current Limit Threshold | Vin = 36 V, Vo < 90% Vonom | 125 | | 150 | %Io,max | |
| Output Ripple ² | Over line and load, -40 °C ≤ T _{AMB} ≤ +85 °C (DC to 20 MHz) | | 50 | 100 | mV _{P-P} | |
| | | | 1.5 | 3.0 | % | |
| | | | 17 | 35 | mV _{RMS} | |
| Dynamic Regulation ³ | 75-100-75% load step change, to 1% error band, Co=0 μF Slew = 1.0A/μs >>> | | | | | |
| | | Peak Deviation | | +/-165 | +/-330 | mV |
| | | Settling Time | | 500 | 1,000 | μs |
| | | Peak Deviation | | +/-165 | +/-330 | mV |
| Settling Time | | 500 | 1,000 | μs | | |
| Efficiency ⁴ | (T _{AMB} =40°C) Vin NOM, Io = I _{RATED} | | 90 | | % | |
| Turn-on Overshoot ⁵ | Overall input voltage, load, and temperature conditions | | 5 | 10 | %Vout | |
| Turn-On Time <i>f</i> (VIN) ⁵ | Time from Vin=UVLO to 90% of Vout _{NOM} | 2 | 10 | 150 | ms | |
| Turn-On Time <i>f</i> (On/Off) ⁶ | Time from enable to 90% of Vout _{NOM} | | 50 | 250 | ms | |
| Rise Time ⁵ | From 10 to 90% of Vout _{NOM} | | 1 | 2 | ms | |
| Admissible Load Capacitance ⁷ | I _{rated} , Nom Vin | 330 | | 8,220 | μF | |
| Switching Frequency | | | 300 | | kHz | |

Notes:

¹ see Figures 37 and 40

² see Figure 18 for ripple waveform and Figure 46 for measurement method.

³ see Figures 12 and 15

⁴ see Figure 3

⁵ see Figure 6

⁶ see Figure 9

⁷ A minimum 330 μF (AVX, TPSD337K006R0045) is recommended for operation over full load, line and temperature range.

Output Specifications (Cont'd)

All specifications apply over specified input voltage, output load, and @ 40 °C ambient temperature, unless otherwise noted.

QMS14DG: 5V / 14A

| Parameter | Conditions/Description | Min | Nom | Max | Units |
|--|---|-------|--------|---------|-------------------|
| Output Voltage (Set-point) | $V_i = 36\text{ V}$, $I_o = 14\text{ A}$ | 4.925 | 5.0 | 5.075 | VDC |
| Line Regulation | $V_i = 18\text{ V}$ to 60 V , $I_o = 50\% I_{o,max}$ | | | 15 | mV |
| | | | | 0.3 | % |
| Load Regulation | $V_i = 36\text{ V}$, I_o .min to I_o .max | | | 25 | mV |
| | | | | 0.5 | % |
| Temperature Coefficient | $-40\text{ °C} \leq T_{AMB} \leq +85\text{ °C}$ | | | 0.02 | %/°C |
| Total Error Band | (Line, Load, Temperature, Ripple, Life) | 4.76 | | 5.24 | VDC |
| | | | | +/- 4.8 | % |
| Output Power ¹ | w/ proper thermal derating | | | 70 | W |
| Output Current ¹ | w/ proper thermal derating | 0 | | 14 | A |
| Output Current Limit Threshold | $V_{in} = 36\text{ V}$, $V_o < 90\% V_{onom}$ | 120 | | 160 | % $I_{o,max}$ |
| Output Ripple ² | Over line and load, $-40\text{ °C} \leq T_{AMB} \leq +85\text{ °C}$ (DC to 20 MHz) | | 50 | 120 | mV _{P-P} |
| | | | 1.0 | 2.4 | % |
| | | | 17 | 42 | mVrms |
| Dynamic Regulation ¹ | 75-100-75% load step change, to 1% error band, $C_o = 0\text{ }\mu\text{F}$ Slew = $1.0\text{ A}/\mu\text{s} \gg \gg$ | | +/-250 | +/-500 | mV |
| | | | 500 | 1,000 | μs |
| | | | +/-250 | +/-500 | mV |
| | | | 500 | 1,000 | μs |
| Efficiency ⁴ | $(T_{AMB} = 40\text{ °C})$ $V_{in,NOM}$, $I_o = I_{RATED}$ | | 92 | | % |
| Turn-on Overshoot ⁵ | Overall input voltage, load, and temperature conditions | | 5 | 10 | % V_{out} |
| Turn-On Time $f(VIN)$ ⁵ | Time from $V_{in} = UVLO$ to 90% of $V_{out,NOM}$ | 2 | 10 | 150 | ms |
| Turn-On Time $f(On/Off)$ ⁶ | Time from enable to 90% of $V_{out,NOM}$ | | 50 | 250 | ms |
| Rise Time ⁵ | From 10 to 90% of $V_{out,NOM}$ | | 3 | 6 | ms |
| Admissible Load Capacitance ⁷ | I_{RATED} , Nom V_{in} | 220 | | 4,600 | μF |
| Switching Frequency | | | 330 | | kHz |

Notes:

¹ see Figures 38 and 41

² see Figure 19 for ripple waveform and Figure 46 for measurement method.

³ see Figures 13 and 16

⁴ see Figure 4

⁵ see Figure 7

⁶ see Figure 10

⁷ A minimum 220 μF (AVX, TPSD227K010R0050) is recommended for operation over full load, line and temperature range.

Output Specifications (Cont'd)

All specifications apply over specified input voltage, output load, and @ 40 °C ambient temperature, unless otherwise noted.

QMS07DH: 12V / 6.75A

| Parameter | Conditions/Description | Min | Nom | Max | Units |
|--|---|-------|--------|----------|-------------------|
| Output Voltage (Set-point) | $V_i = 36\text{ V}$, $I_o = 6.75\text{ A}$ | 11.82 | 12.0 | 12.18 | VDC |
| Line Regulation | $V_i = 18\text{ V to } 60\text{ V}$, $I_o = 50\% I_{o,max}$ | | | 60 | mV |
| | | | | 0.5 | % |
| Load Regulation | $V_i = 36\text{ V}$, $I_{o,min}$ to $I_{o,max}$ | | | 60 | mV |
| | | | | 0.5 | % |
| Temperature Coefficient | $-40\text{ °C} \leq T_{AMB} \leq +85\text{ °C}$ | | | 0.02 | %/°C |
| Total Error Band | (Line, Load, Temperature, Ripple, Life) | 11.44 | | 12.56 | VDC |
| | | | | +/- 4.7 | % |
| Output Power ¹ | w/ proper thermal derating | | | 81 | W |
| Output Current ¹ | w/ proper thermal derating | 0 | | 6.75 | A |
| Output Current Limit Threshold | $V_{in} = 36\text{ V}$, $V_o < 90\% V_{onom}$ | 130 | | 170 | % $I_{o,max}$ |
| Output Ripple ² | Over line and load, $-40\text{ °C} \leq T_{AMB} \leq +85\text{ °C}$ (DC to 20 MHz) | | 120 | 200 | mV _{P-P} |
| | | | 1.0 | 1.67 | % |
| | | | 42 | 70 | mV _{RMS} |
| Dynamic Regulation ³ | 75-100-75% load step change, to 1% error band, $C_o = 0\text{ }\mu\text{F}$ Slew = $1.0\text{ A}/\mu\text{s} \gg \gg$ | | +/-600 | +/-1,200 | mV |
| | | | 500 | 1,000 | μs |
| | | | +/-600 | +/-1,200 | mV |
| | | | 500 | 1,000 | μs |
| Efficiency ⁴ | ($T_{AMB} = 40\text{ °C}$) $V_{in,NOM}$, $I_o = I_{RATED}$ | | 92 | | % |
| Turn-on Overshoot ⁵ | Overall input voltage, load, and temperature conditions | | 5 | 10 | % V_{out} |
| Turn-On Time $f(VIN)$ ⁵ | Time from $V_{in} = UVLO$ to 90% of $V_{out,NOM}$ | 2 | 50 | 150 | ms |
| Turn-On Time $f(On/Off)$ ⁶ | Time from enable to 90% of $V_{out,NOM}$ | | 50 | 250 | ms |
| Rise Time ⁵ | From 10 to 90% of $V_{out,NOM}$ | | 4 | 8 | ms |
| Admissible Load Capacitance ⁷ | I_{rated} , Nom V_{in} | 68 | | 2,200 | μF |
| Switching Frequency | | | 330 | | kHz |

Notes:

¹ see Figures 39 and 42

² see Figure 20 for ripple waveform and Figure 46 for measurement method.

³ see Figures 14 and 17

⁴ see Figure 5

⁵ see Figure 8

⁶ see Figure 11

⁷ A minimum 68 μF (AVX, TPSD686K020R0070) is recommended for operation over full load, line and temperature range.

Protections Specifications

All specifications apply over specified input voltage, output load, and @ 40 °C ambient temperature, unless otherwise noted.

| Parameter | Conditions/Description | Min | Nom | Max | Units |
|--|---|------|-----|------|------------------|
| Overcurrent Protection | | | | | |
| Type | Non-latching – auto-recovery, hiccup type. | | | | |
| Threshold | QMS25DE | 31.2 | | 37.5 | ADC |
| | QMS14DG | 16.8 | | 22.4 | ADC |
| | QMS07DH | 8.8 | | 11.5 | ADC |
| Short Circuit ¹ | QMS25DE | | 17 | 30 | A _{RMS} |
| | QMS14DG | | 17 | 22 | A _{RMS} |
| | QMS07DH | | 12 | 15 | A _{RMS} |
| Overvoltage Protection ² | | | | | |
| Type | Clamp, non-latching, hiccup mode. Independent control loop, auto-reset. | | | | |
| Threshold | | 115 | | 140 | %Vo |
| Overtemperature Protection | | | | | |
| Type | Non-latching, auto-recovery | | | | |
| Threshold | Temperature node: T _C ³ | | 135 | | °C |

¹ Refer to Figures 21, 22, 23.

² Refer to Figures 24 – 29

³ Refer to Figure 36.

Feature Specifications

All specifications apply over specified input voltage, output load, and @ 40 °C ambient temperature, unless otherwise noted.

| Parameter | Conditions/Description | Min | Nom | Max | Units |
|---|---|----------|-----|------------|-------------|
| On/Off ¹ | | | | | |
| Negative Logic (-N suffix) | (On/Off signal is low – converter is ON) | | | | |
| On/Off (pin 2) (Primary side ref. to -Vin) | Converter ON Sink current | -0.7 | | 0.8 1.0 | VDC mADC |
| | Converter OFF Open circuit voltage | 3.5 7 | | 20 18 | VDC VDC |
| Positive Logic (-P suffix) | (On/Off signal is high – converter is ON) | | | | |
| On/Off (pin 2) (Primary side ref. to -Vin) | Converter ON Open Circuit Voltage | 3.5 7 | | 20 18 | VDC VDC |
| | Converter OFF Sink current | -0.7 | | 0.8 1.0 | VDC mADC |
| Remote Sense | | | | | |
| Remote Sense Headroom | | | | 10 | %Vo |
| Output Voltage Trim ² | | | | | |
| Trim Up | | | | 10 | %Vo |
| Trim Down | | -10 | | | %Vo |

¹ See Figure 30.

² The output voltage of the units can be increased to a maximum of 10%. This is comprised of a combination of the remote-sense and trim adjustment. Do not exceed 10% of Vonom between +Vout and -Vout terminals. Also refer to "Output Voltage Adjust" section and Figures 31 – 35 for clarification.)

Performance Characteristic

Reflected Ripple Current

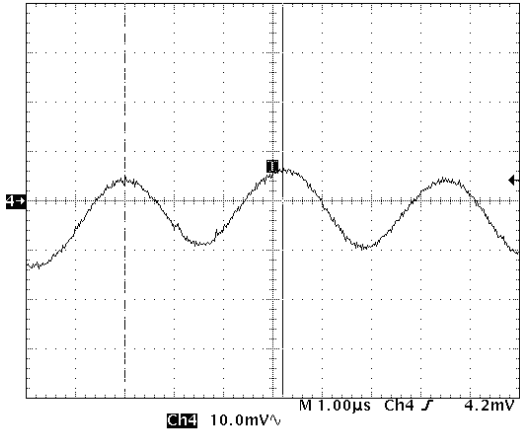

Figure 1. QMS25DE, Input Reflected Ripple Current (typ.)

Conditions: Output current = 25 ADC (82.5 W).
Input voltage = 36 VDC.
Waveform: $I_{RRC} < 10 \text{ mA}_{P-P}$ (measured)
Scale : 5mA/10mV or 5mA/division.

Undervoltage Lockout Characteristics (typ)

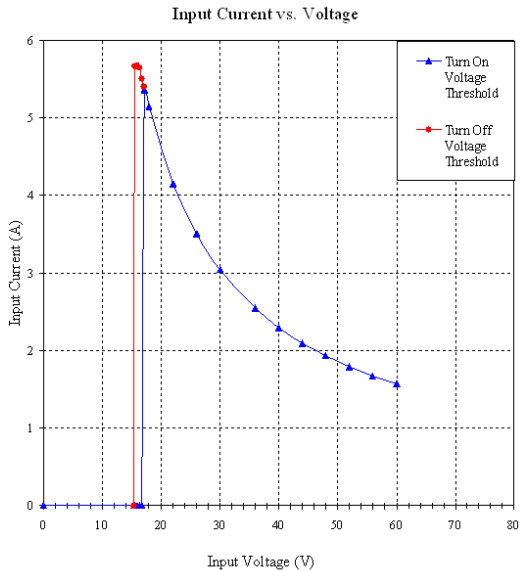

Figure 2. UVLO Input Characteristics

Efficiency

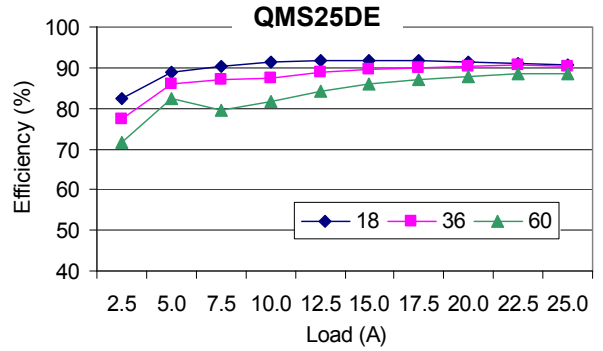

Figure 3. Efficiency, f (Line & load)

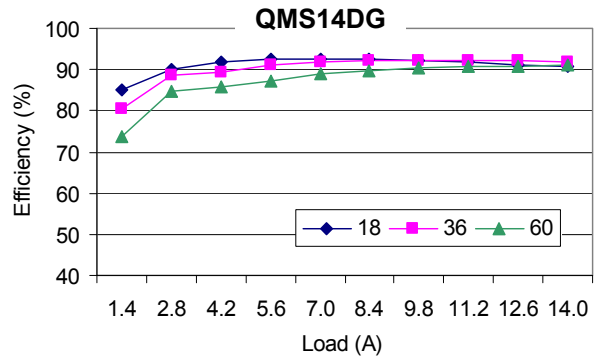

Figure 4. Efficiency, f (Line & load)

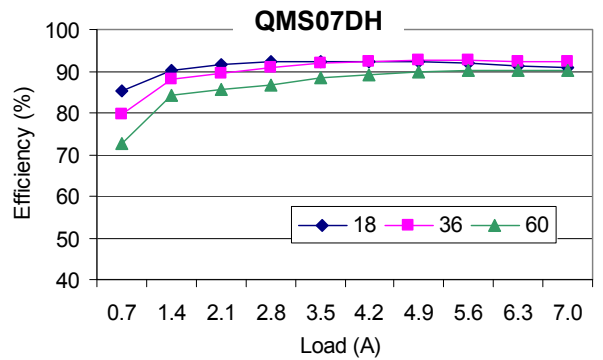

Figure 5. Efficiency, f (Line & load)

Vo Turn-on Characteristics, $f(V_{IN})$

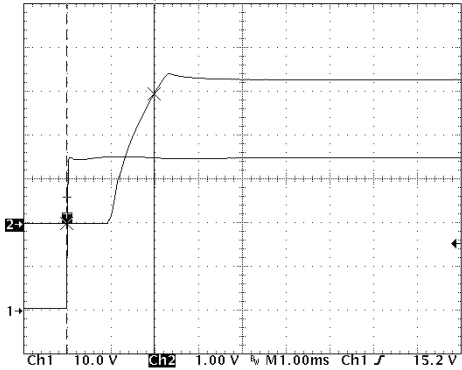
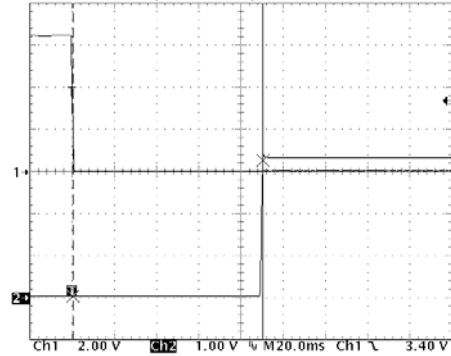

Figure 6. QMS25DE, Turn-On @ Power-up (typ)

Conditions: V_{in} max., $C_{ext} = 0 \mu F$ Output current: 25 ADC
 Channel 1 - Input voltage = 36 VDC Scale : 10V/div., 1ms/div.
 Channel 2 - V_{out} , $T_{RISE} = 1$ ms Scale : 1V/div.

Vo Turn-on Characteristics, $f(ON/OFF)$



Negative Logic shown

Figure 9. QMS25DE, Turn-On via On/Off Ctrl (typ)

Conditions: $V_{in} = 36$ VDC, $C_{ext} = 0 \mu F$ Output current: 25 ADC
 Channel 1 - On/Off signal Scale : 2V/div.
 Channel 2 - Output voltage Amplitude = 1V/div.
 Time base = 20 ms/div. Delay time = 90ms (typ.)

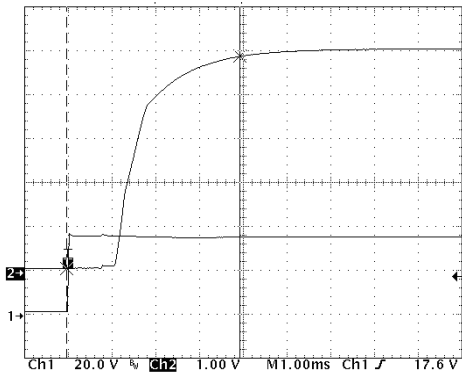
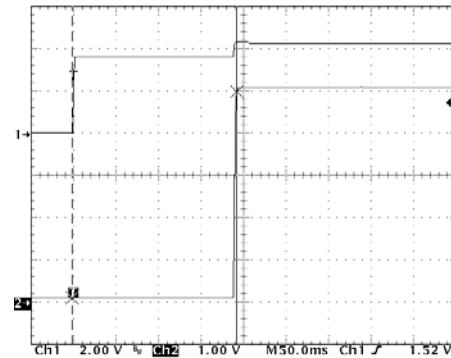

Figure 7. QMS14DG, Turn-On @ Power-up (typ)

Conditions: V_{in} max., $C_{ext} = 0 \mu F$ Output current: 14 ADC
 Channel 1 - Input voltage = 36 VDC Scale : 20V/div., 1ms/div.
 Channel 2 - V_{out} , $T_{RISE} = 3$ ms Scale : 1V/div.



Positive Logic shown

Figure 10. QMS14DG, Turn-On via On/Off Ctrl (typ)

Conditions: $V_{in} = 36$ VDC, $C_{ext} = 0 \mu F$ Output current: 14 ADC
 Channel 1 - On/Off signal Scale : 2V/div.
 Channel 2 - Output voltage Amplitude = 1V/div.
 Time base = 50 ms/div. Delay time = 200 ms (typ.)

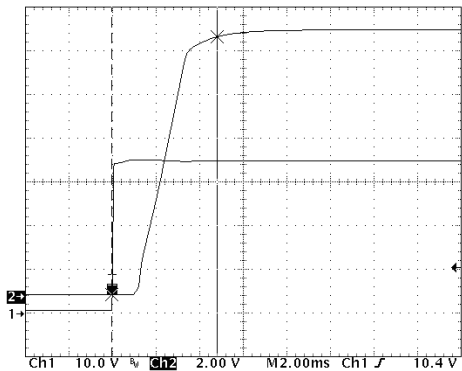
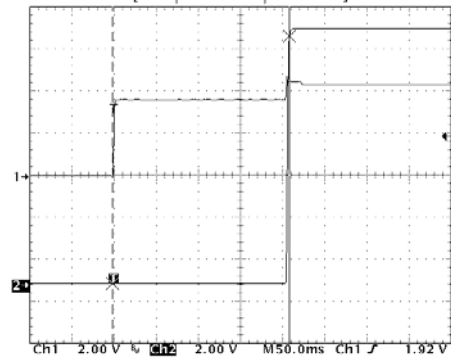

Figure 8. QMS07DH, Turn-On @ Power-up (typ)

Conditions: V_{in} max., $C_{ext} = 0 \mu F$ Output current: 6.75 ADC
 Channel 1 - Input voltage = 36 VDC Scale : 10V/div., 2ms/div.
 Channel 2 - V_{out} , $T_{RISE} = 4$ ms Scale : 2V/div.



Positive Logic shown

Figure 11. QMS07DH, Turn-On via On/Off Ctrl (typ)

Conditions: $V_{in} = 36$ VDC, $C_{ext} = 0 \mu F$ Output current: 6.75 ADC
 Channel 1 - On/Off signal Scale : 2V/div.
 Channel 2 - Output voltage Amplitude = 2V/div.
 Time base = 50 ms/div. Delay time = 200 ms (typ.)

Dynamic Load Response

Conditions: $V_{in} = 36 \text{ VDC}$, $C_{ext} = 0 \mu\text{F}$

Scale : 500 mV/div, 200 μs /div.

Load: (25% load Δ) with **slew rate: 1.0A/ μs**

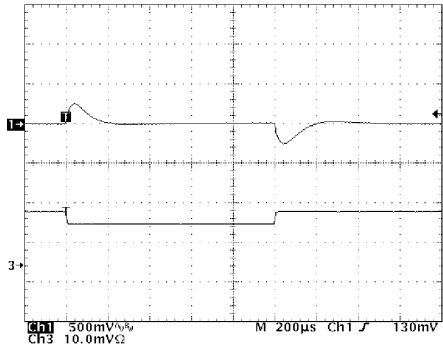

Figure 12. QMS25DE Load Response (typ)

Channel 1- Voltage deviation: ~ 250 mV_P (measured)
Channel 3 – Load switched from 18.75 A to 25 A

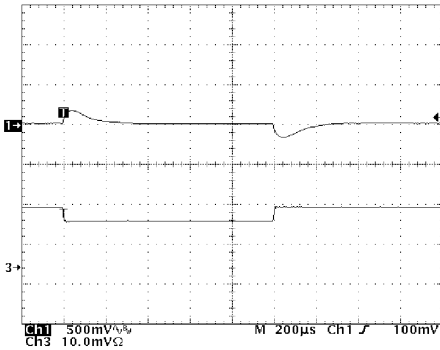

Figure 13. QMS14DG, Load Response (typ)

Channel 1- Voltage deviation: ~ 175 mV_P (measured)
Channel 3 - Load switched from 10.5 A to 14 A

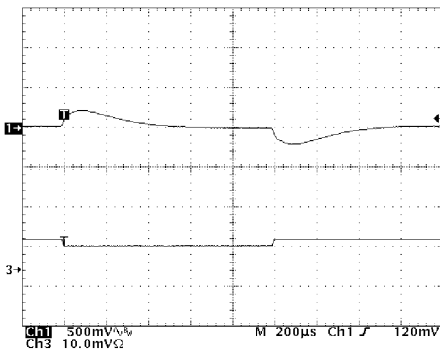

Figure 14. QMS07DH, Load Response (typ)

Channel 1- Voltage deviation: ~ 225 mV_P (measured)
Channel 3 - Load switched from 5.0 A to 6.75 A

Conditions: $V_{in} = 36 \text{ VDC}$, $C_{ext} = 0 \mu\text{F}$

Scale : 500 mV/div, 200 μs /div.

Load: (25% load Δ) with **slew rate: 0.1A/ μs**

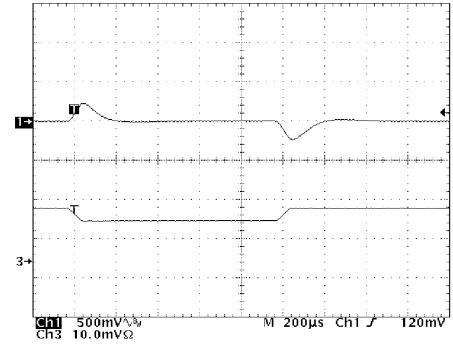

Figure 15. QMS25DE, Load Response (typ)

Channel 1- Voltage deviation: ~ 250 mV_P (measured)
Channel 3 - Load switched from 18.75 A to 25 A

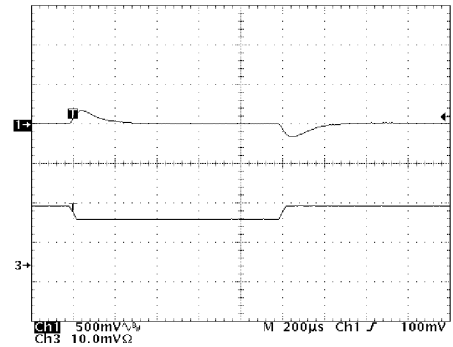

Figure 16. QMS14DG, Load Response (typ)

Channel 1- Voltage deviation: ~ 200 mV_P (measured)
Channel 3 - Load switched from 10.5 A to 14 A

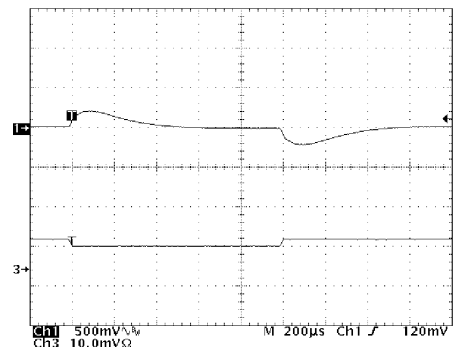

Figure 17. QMS07DH, Load Response (typ)

Channel 1- Voltage deviation: ~ 225 mV_P (measured)
Channel 3 - Load switched from 5.0 A to 6.75 A

Output Ripple and Noise (Typ, $-40^{\circ}\text{C} \leq T_{\text{AMB}} \leq +85^{\circ}\text{C}$)

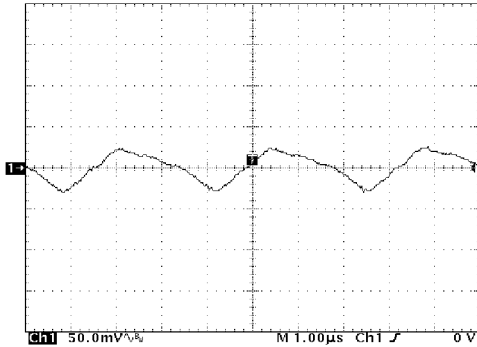

Figure 18. QMS25DE Output Ripple & Noise (typ.)

Conditions: $V_{\text{in}} = 60\text{ V}$ and $I_{\text{out}} = 25\text{ A}$.
Channel 1 - V_{o} , (AC coupled), $\sim 50\text{ mV}_{\text{P-P}}$ (measured)

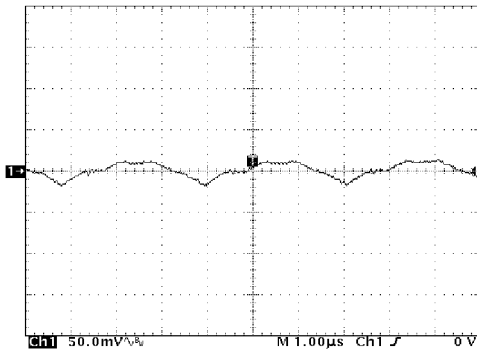

Figure 19. QMS14 Output Ripple & Noise (typ.)

Conditions: $V_{\text{in}} = 60\text{ V}$ and $I_{\text{out}} = 14\text{ A}$.
Channel 1 - V_{o} , (AC coupled), $\sim 35\text{ mV}_{\text{P-P}}$ (measured)

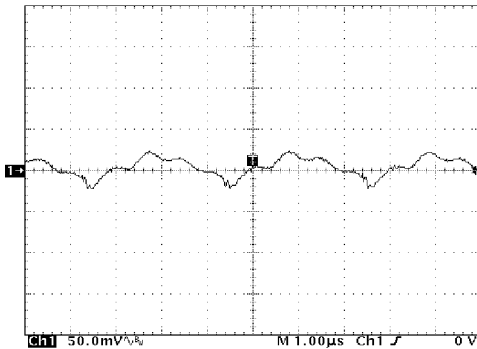
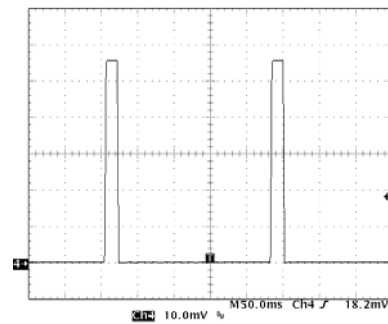

Figure 20. QMS07 Output Ripple & Noise (typ.)

Conditions: $V_{\text{in}} = 60\text{ V}$ and $I_{\text{out}} = 6.75\text{ A}$.
Channel 1 - V_{o} , (AC coupled), $\sim 50\text{ mV}_{\text{P-P}}$ (measured)

Overcurrent Protection

When the output is loaded above the maximum output current rating, the voltage of the converter will reduce to maintain the output power at a safe level. In the case of a high overload or short circuit condition where the output voltage is pulled below 50% of $V_{\text{o-nom}}$, the unit will enter into a "hiccup" mode of operation. Under this condition, the converter will attempt to restart, typically every 250 ms, until the overload has cleared. Because of very low duty cycle, the RMS value of output current is kept low. Once the output current is reduced to within its rated range, the converter automatically exits the hiccup mode and continues normal operation.



QMS25DE

Condition: $V_{\text{in}}=60\text{VDC}$
 $I_{\text{SC}} < 30\text{ A}_{\text{RMS}}$
Scale: 10 Amp/div.

Figure 21, Short Circuit Behavior (typ.)

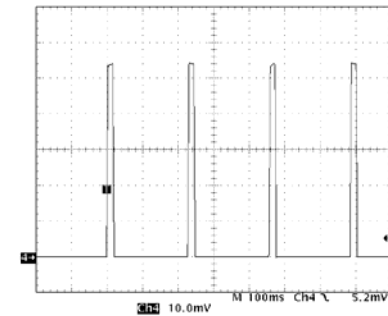

QMS14DG

Condition: $V_{\text{in}}=60\text{VDC}$
 $I_{\text{SC}} < 22\text{ A}_{\text{RMS}}$
Scale: 10 Amp/div.

Figure 22, Short Circuit Behavior (typ.)

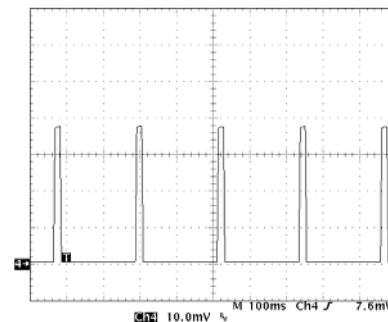

QMS07DH

Condition: $V_{\text{in}}=60\text{VDC}$
 $I_{\text{SC}} < 15\text{ A}_{\text{RMS}}$
Scale: 10 Amp/div.

Figure 23, Short Circuit Behavior (typ.)

Pre-bias Conditions

The QMS converters will start-up into a pre-bias voltage of 50% V_{ONOM} without damage.

Overvoltage Protection

The output overvoltage protection consists of a separate control loop, independent of the primary control loop. This secondary control loop has a higher voltage set point than the primary loop. In a fault condition, the converter enters a “Hiccup” mode of operation, and ensures that the output voltage does not exceed V_{ovp} max.

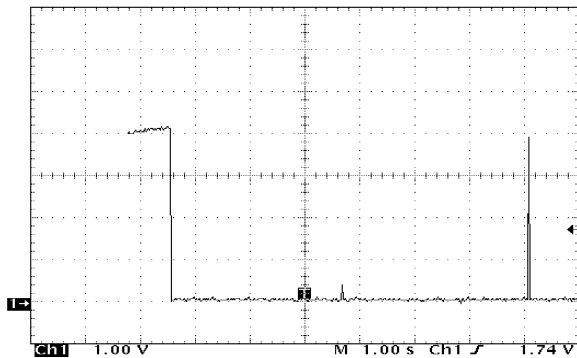
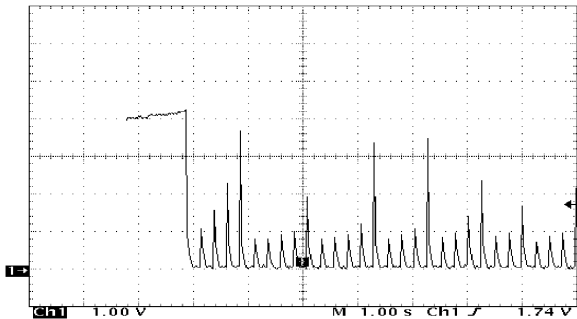

Figure 24. QMS25DE, Induced OVP Behavior (typ.)

Conditions: $V_{in} = 36\text{ V}$, $I_{out} = 75\%$ load.
Channel 1- V_o , Scale: 1 V/div., 1 sec.div.



QMS25, min load, 36 V_{in}

Figure 25. QMS25DE, Induced OVP Behavior (typ.)

Conditions: $V_{in} = 36\text{ V}$, $I_{out} = \text{minimum load}$.
Channel 1- V_o , Scale: 1 V/div., 1 sec.div.

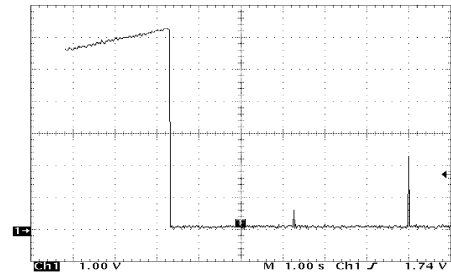

Figure 26. QMS14DG, Induced OVP Behavior (typ.)

Conditions: $V_{in} = 36\text{ V}$, $I_{out} = 75\%$ load.
Channel 1- V_o , Scale: 1 V/div., 1 sec.div.

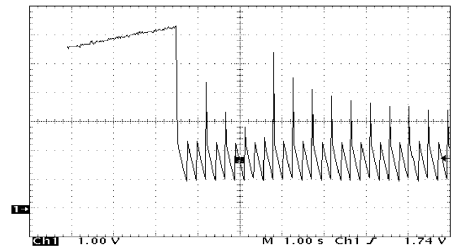

Figure 27. QMS14DG, Induced OVP Behavior (typ.)

Conditions: $V_{in} = 36\text{ V}$, $I_{out} = \text{minimum load}$.
Channel 1- V_o , Scale: 1 V/div., 1 sec.div.

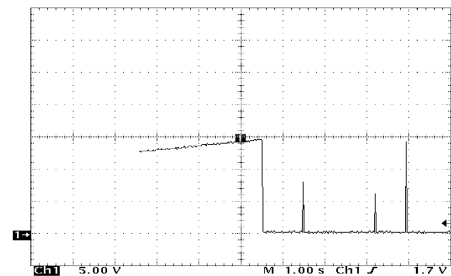

Figure 28. QMS07DH, Induced OVP Behavior (typ.)

Conditions: $V_{in} = 36\text{ V}$, $I_{out} = 75\%$ load.
Channel 1- V_o , Scale: 1 V/div., 1 sec.div.

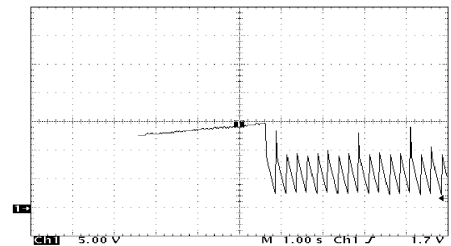

Figure 29. QMS07DH, Induced OVP Behavior (typ.)

Conditions: $V_{in} = 36\text{ V}$, $I_{out} = \text{minimum load}$.
Channel 1- V_o , Scale: 1 V/div., 1 sec.div.

Typical Application

Input and Output Impedance

The QMS-Series has been designed for stability without external capacitance when used in low inductance input and output circuits. In many applications, the inductance associated with the distribution of the power source to the input of the power converter can negatively affect a converter's stability. The addition of a 33 μ F electrolytic capacitor with an ESR \leq 100 m Ω , across the input helps to ensure stability of the converter. This capacitor should be of suitably high quality and rated for effective use at low temperatures as needed.

Refer to the **"Inrush Current Control Application Note"** on www.power-one.com for suggestions on how to limit the magnitude of the inrush current.

Additionally, see the EMC section further below in this datasheet for discussion for other external component which may be required for reduction of conducted emissions.

The QMS can support high amounts of output capacitance. Refer to **"Output Specification"** tables for details.

Inrush Current

Refer to the **"Inrush Current Control Application Note"**: (http://www.power-one.com/technical/articles/dc-dc_1-app.pdf) for suggestions on how to limit the magnitude of the inrush current.

Features Description

ON/OFF Control

(-x) "no suffix" model

With the **positive logic** model, when the ON/OFF pin is pulled low, the output is turned off and the unit draws less than 25 mA of input current. If the ON/OFF pin is not used, it can be left floating.

(-N) suffix model

With **negative logic**, when the ON/OFF pin is pulled low, the unit is turned on. If the ON/OFF pin is not used, it can be connected to the -Vin pin.

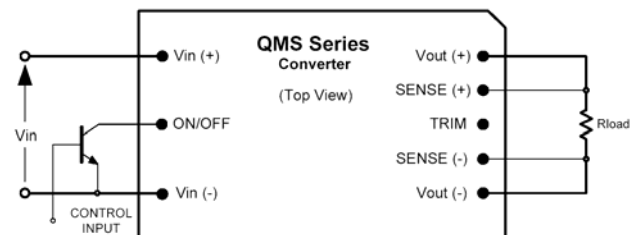

Figure 30. On/Off Control

(Common to -x & -N models)

The ON/OFF pin in the QMS converter functions as a normal soft shutdown. The ON/OFF pin is pulled up internally, so no external voltage source is required or recommended. The user should avoid connecting a resistor between the ON/OFF pin and the +Vin pin. The ON/OFF pin is internally referenced to the -Vin pin. An open collector switch is recommended to control the voltage between these two points.

The controlling signal must not be referenced ahead of EMI filtering, or remotely from the unit. Optical coupling the control signal and locating the opto-coupler directly at the converter, is recommended for trouble-free operation.

Output Voltage Adjustment (Trim)

The industry-standard trim feature allows the user to adjust the output voltage from its nominal value. This can be used to accommodate production margin testing.

Output voltage adjustment is accomplished by connecting an external resistor between the **Trim** pin and to either the **+V_{OUT}** or **-V_{OUT}** pins. That below defines the two versions as well as trim equations used to determine a trim resistor value for a certain trim voltage.

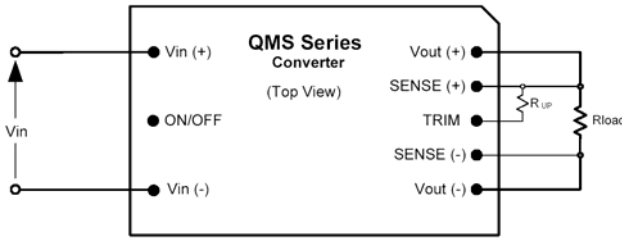

Figure 31. QMS Trim Schematic

With an external resistor (**R_{UP}**) connected between the **Trim** pin and **+V_{OUT}** pin, the output voltage set-point (**V_o**) increases. The following equation determines the required external resistor value to obtain an adjusted output voltage:

$$R_{UP} = \left(\frac{5.11 \cdot V_{out} \cdot (100 + \Delta V\%)}{1.225 \Delta V\%} - \frac{511}{\Delta V\%} - 10.22 \right) \cdot K\Omega$$

Where **Δ%** is the percentage change from **V_{oNOM}**.

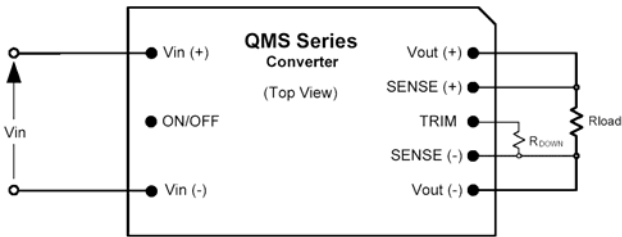

Figure 32. QMS Trim Schematic

With an external resistor (**R_{DOWN}**) between the **Trim** pin and **-V_{OUT}** pin the output voltage set-point (**V_o**) decreases. The following equation determines the required external resistor value to obtain an adjusted output voltage:

$$R_{DOWN} = \left(\frac{511}{\Delta V_o\%} - 10.22 \right) \cdot K\Omega$$

QMS25DE Trim Values:

| Vo Increase | | | Vo Decrease | | |
|-------------|----------------------|---------------------------|-------------|------------------------|---------------------------|
| ΔVo% | R _{UP} (KΩ) | New Vo (V _{DC}) | ΔVo% | R _{DOWN} (KΩ) | New Vo (V _{DC}) |
| 1 | 869 | 3.33 | 1 | 501 | 3.27 |
| 2 | 436 | 3.37 | 2 | 245 | 3.23 |
| 3 | 292 | 3.40 | 3 | 160 | 3.20 |
| 4 | 220 | 3.43 | 4 | 118 | 3.17 |
| 5 | 177 | 3.47 | 5 | 92 | 3.14 |
| 6 | 148 | 3.50 | 6 | 75 | 3.10 |
| 7 | 127 | 3.53 | 7 | 63 | 3.07 |
| 8 | 112 | 3.56 | 8 | 54 | 3.04 |
| 9 | 100 | 3.60 | 9 | 47 | 3.00 |
| 10 | 90 | 3.63 | 10 | 41 | 2.97 |

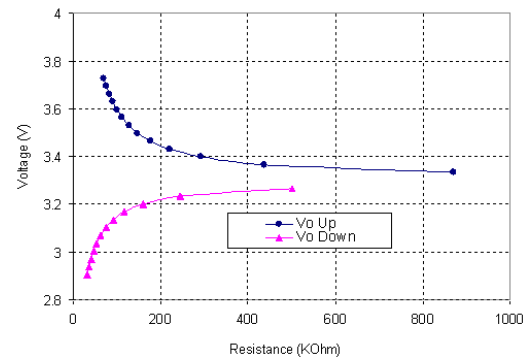

Figure 33. QMS25DE Trim Characteristics

QMS14DG Trim Values

| Vo Increase | | | Vo Decrease | | |
|-------------|----------------------|---------------------------|-------------|------------------------|---------------------------|
| ΔVo% | R _{UP} (KΩ) | New Vo (V _{DC}) | ΔVo% | R _{DOWN} (KΩ) | New Vo (V _{DC}) |
| 1 | 1585 | 5.05 | 1 | 501 | 4.95 |
| 2 | 798 | 5.10 | 2 | 245 | 4.90 |
| 3 | 536 | 5.15 | 3 | 160 | 4.85 |
| 4 | 404 | 5.20 | 4 | 118 | 4.80 |
| 5 | 326 | 5.25 | 5 | 92 | 4.75 |
| 6 | 273 | 5.30 | 6 | 75 | 4.70 |
| 7 | 236 | 5.35 | 7 | 63 | 4.65 |
| 8 | 207 | 5.40 | 8 | 54 | 4.60 |
| 9 | 186 | 5.45 | 9 | 47 | 4.55 |
| 10 | 168 | 5.50 | 10 | 41 | 4.50 |

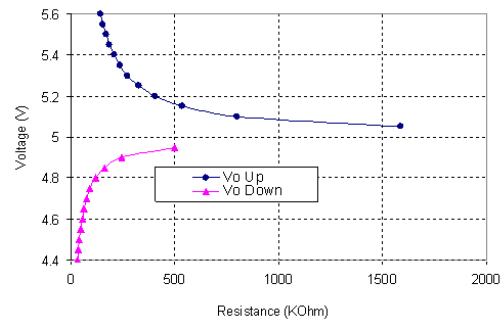

Figure 34. QMS14DG Trim Characteristics

QMS07DH Trim Values

| Vo Increase | | | Vo Decrease | | |
|----------------|-------------------------------|---------------------------|----------------|---------------------------------|---------------------------|
| $\Delta V_o\%$ | R _{UP} (K Ω) | New Vo (V _{DC}) | $\Delta V_o\%$ | R _{DOWN} (K Ω) | New Vo (V _{DC}) |
| 1 | 4535 | 12.12 | 1 | 501 | 11.88 |
| 2 | 2287 | 12.24 | 2 | 245 | 11.76 |
| 3 | 1538 | 12.36 | 3 | 160 | 11.64 |
| 4 | 1164 | 12.48 | 4 | 118 | 11.52 |
| 5 | 939 | 12.60 | 5 | 92 | 11.40 |
| 6 | 789 | 12.72 | 6 | 75 | 11.28 |
| 7 | 682 | 12.84 | 7 | 63 | 11.16 |
| 8 | 602 | 12.96 | 8 | 54 | 11.04 |
| 9 | 539 | 13.08 | 9 | 47 | 10.92 |
| 10 | 489 | 13.20 | 10 | 41 | 10.80 |

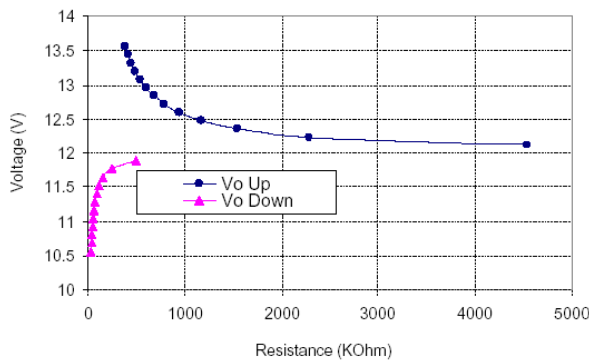

Figure 35. QMS07DH Trim Characteristics

Notes:

1. When the output voltage is trimmed up, the output power from the converter must not exceed its maximum rating. The power is determined by measuring the output voltage on the output pins, and multiplying it by the output current.
2. In order to avoid creating apparent load regulation degradation, it is important that the trim resistors be connected directly to the remote sense pins, and not to the load or to traces going to the load.
3. The output voltage increase can be accomplished either by the trim or by the remote sense or by the combination of both. In any case, the absolute maximum output voltage increase shall not exceed the limits defined in the *Features Specification* section above.
4. Either Rup or Rdown should be used to adjust the output voltage according to the equations above. If both Rup and Rdown are used simultaneously, they will form a resistive divider and the equations above will not apply.

Thermal Considerations

QMS converters are designed for both natural and forced convection cooling. To achieve long term reliability, the recommended power derating curves below, were established by comparing measured junction and hot spot temperatures against those allowed per Power-One's component derating guidelines

The graphs in Figures 37 thru 42 show the maximum recommended output current of each QMS converter at various ambient temperatures under both natural and forced convection cooling (longitudinal airflow direction, from pin 1 to pin 3). Vin for both 24 VDC and 48 VDC conditions are shown.

Thermal Measurements

Measurements requiring airflow were made in Power-One's vertical wind tunnel equipment using both Infrared (IR) thermography as well as the traditional thermocouple method. The converter was soldered to a test board consisting of a 0.060" thick printed wiring board (PWB) with four layers. The top and bottom layers were not metalized. The two inner layers, comprised of two-ounce copper, were used to provide traces for connectivity to the converter. The lack of metalization on the outer layers as well as the limited thermal connection ensured that heat transfer from the converter to the PWB was minimized. This provides a worst-case but consistent scenario for thermal derating purposes.

With the converter installed into the host application, customer verification that all components are at or below their safe operating temperatures may be performed similarly. However, for a more simplified testing method, monitoring the converter's designated thermal reference point (T_C) will yield effective results. The recommended location of the measuring thermocouple is shown below. This reference point should be maintained at $\leq 125^\circ\text{C}$.

It is recommended to use a 32AWG to 40AWG thermocouple wire probe on the location identified below; labeled T_C

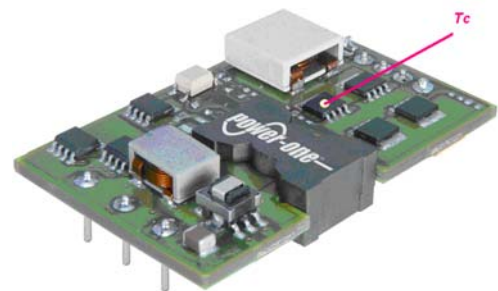

Figure 36. Thermal Reference, T_C.
(QMS25DE shown)

Power Derating f (V_{IN} , T_A , Airflow)

Direction of airflow: from $-V_{IN}$ (Pin 1) to $+V_{IN}$ (Pin 3)

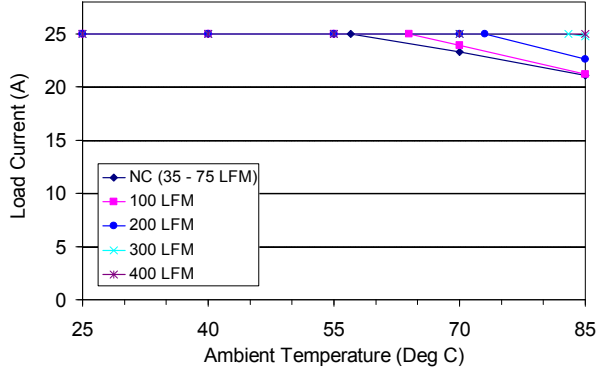

Figure 37. QMS25DE, $V_{in} = 24$ VDC

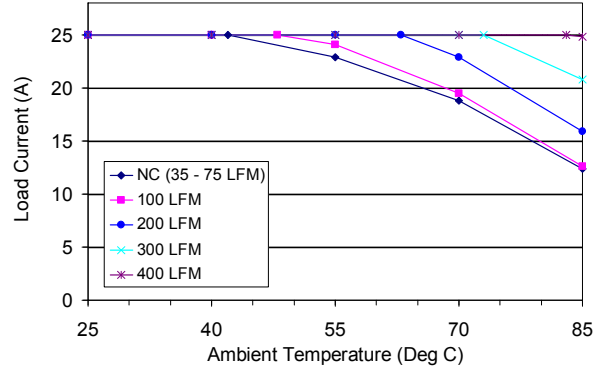

Figure 40. QMS25DE, $V_{in} = 48$ VDC

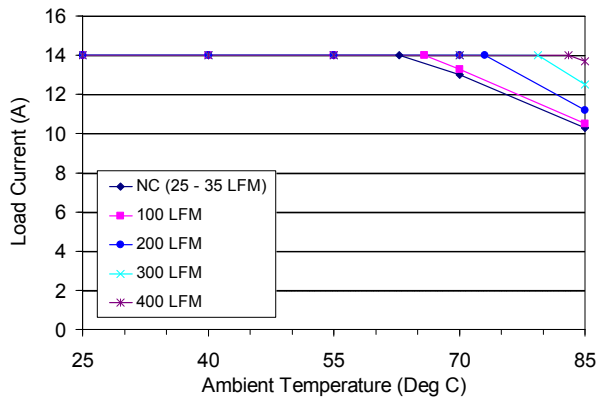

Figure 38. QMS14DG, $V_{in} = 24$ VDC

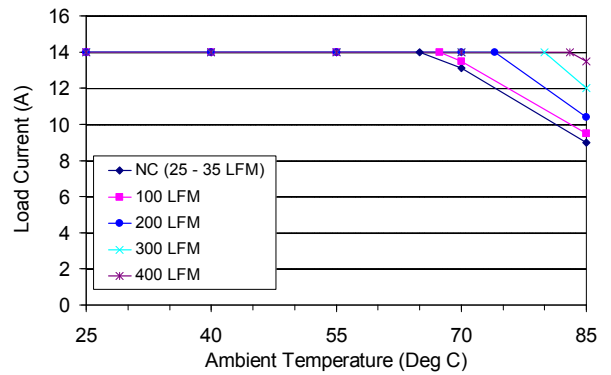

Figure 41. QMS14DG, $V_{in} = 48$ VDC

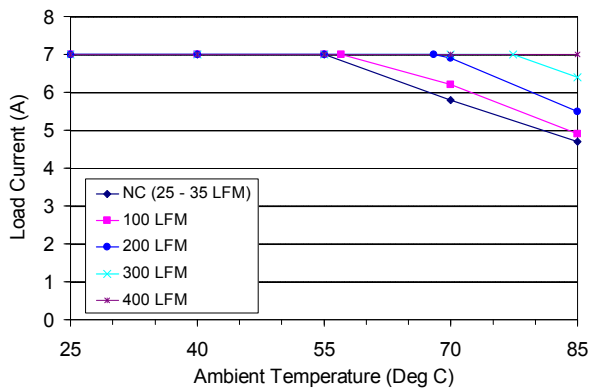

Figure 39. QMS07DH, $V_{in} = 24$ VDC

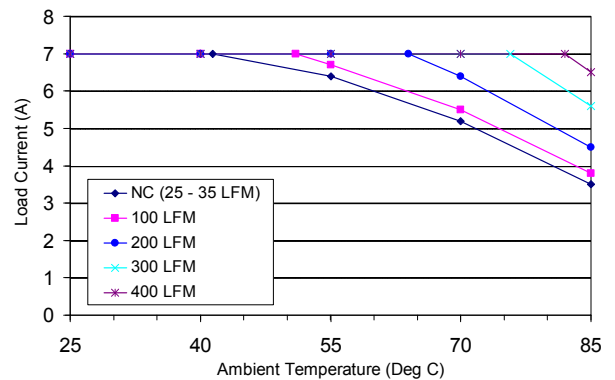

Figure 42. QMS07DH, $V_{in} = 48$ VDC

Safety Considerations

The QMS converters feature 1500 VDC isolation from the input-to-output. The input-to-output resistance is greater than 10 MΩ. These converters are provided with Basic insulation between input and output circuits according to all IEC60950 based standards. Nevertheless, if the system using the converter needs to receive safety agency approval, certain rules must be followed in the design of the system. In particular, all of the creepage and clearance requirements of the end-use safety requirements must be observed. These documents include UL60950 - CSA60950-00 and EN60950, although other or additional requirements may be needed for specific applications.

The QMS converter has no internal fuse. **The external fuse must be provided to protect the system from catastrophic failure.** Refer to the “Input Fuse Selection for DC/DC converters” application note on www.power-one.com for proper selection of the input fuse. Both input traces and the chassis ground trace (if applicable) must be capable of conducting a current of 1.5 times the value of the fuse without opening. The fuse must not be placed in the grounded input line, if any.

In order for the output of the QMS converter to be considered as SELV (Safety Extra Low Voltage) or TNV-1, according to all IEC60950 based standards, one of the following requirements must be met in the system design:

- If the voltage source feeding the module is SELV or TNV-2, the output of the converter may be grounded or ungrounded.
- If the voltage source feeding the module is ELV, the output of the converter may be considered SELV only if the output is grounded per the requirements of the standard.
- If the voltage source feeding the module is a Hazardous Voltage Secondary Circuit, the voltage source feeding the module must be provided with at least Basic insulation between the source to the converter and any hazardous voltages. The entire system, including the QMS converter, must pass a dielectric withstand test for Reinforced insulation. Design of this type of system requires expert engineering and understanding of the overall safety requirements and should be performed by qualified personnel.

Note: This information is provided for guidance only and the user is responsible for any design considerations regarding safety.

Conducted EMI

The following conducted EMI filter configuration and component values are offered as a guideline to assist in designing an effective filter solution in the actual application. Many factors can affect overall EMI performance; such as layout, wire routing and load characteristics, among others. As a result, the final circuit configuration and component values may require adjustment.

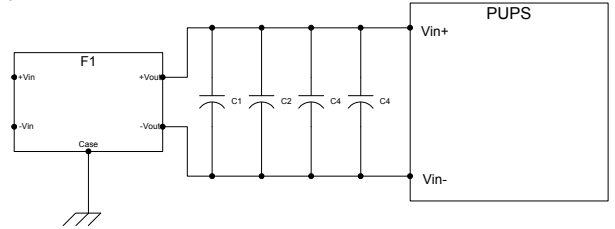

Figure 43. EMI Filter Configuration

| Ref. Des | Description | Manufacturer |
|----------|----------------------------------|--------------------------------|
| C1, C2 | 1 μF @100V MLC | AVX or Equivalent |
| C3, C4 | 100 μF @ 100V Alum. Electrolytic | Panasonic NGH Series or Equiv. |
| F1 | FC100V10A Input Filter Module | Power-One |

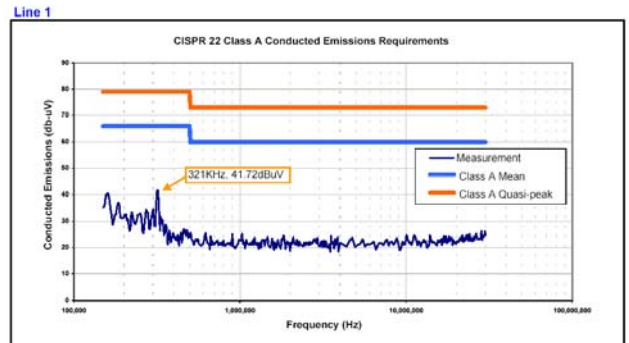

Figure 44. Conducted EMI Scan of the QMS25DE

(w/ Input Filter Components Designated in Table Above.)

Test conditions: Vin = 36 VDC, Io = 100% rated (82.5 W)

Test Specification: (CISPR-22) NE55022 Class A (Peak Detect)

Conducted EMI, con't

Alternate - Minimum Margin Filter Design

| Ref. Des | Description | Manufacturer |
|----------|-------------------------------|--------------|
| C1 – C4 | Not Used | N/A |
| F1 | FC100V10A Input Filter Module | Power-One |

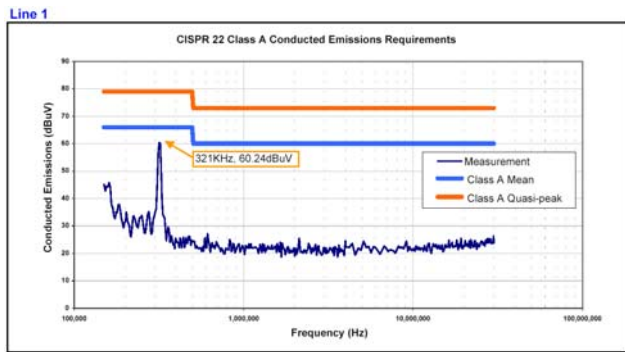

Figure 45. Conducted EMI Scan of the QMS25DE
(w/ Input Filter Components Designated in Table Above.)

Test conditions: $V_{in} = 36$ VDC, $I_o = 100\%$ rated (82.5 W)
Test Specification: (CISPR-22) NE55022 Class A (Peak Detect)

Other Measurement Methods

To improve the accuracy and repeatability of ripple and noise measurements, Power-One utilizes the test setups shown in Figure 46 & 47 below.

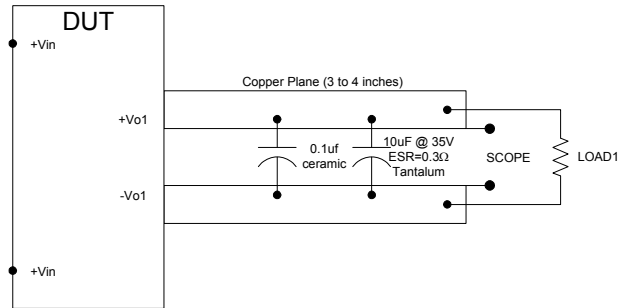

Figure 46. Output Ripple and Noise Set-up.

A BNC connector is used for measurements to eliminate noise pickup associated with long ground leads of conventional scope probes. The load is located 3" to 4" away from the converter.

For output decoupling, we recommend using a 10 μ F low ESR tantalum (AVX TPSC106M025R0500 is used in Power-One test setup) and a 0.1 μ F ceramic capacitor. Note that the capacitors do not substitute for filtering required by the load.

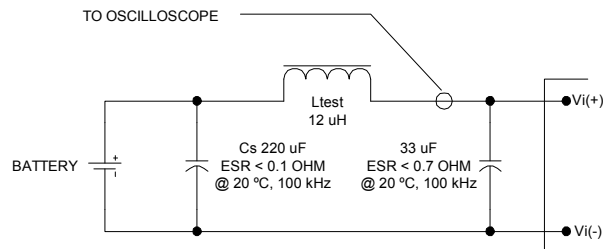
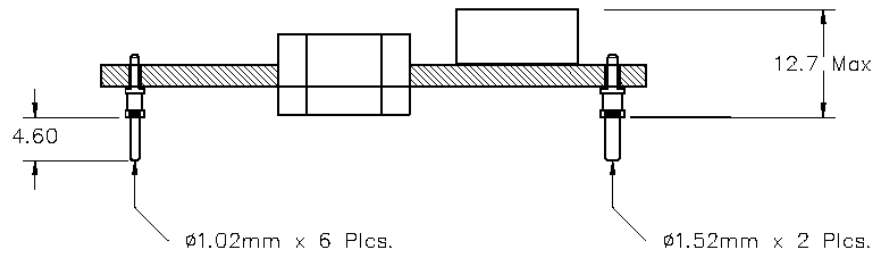
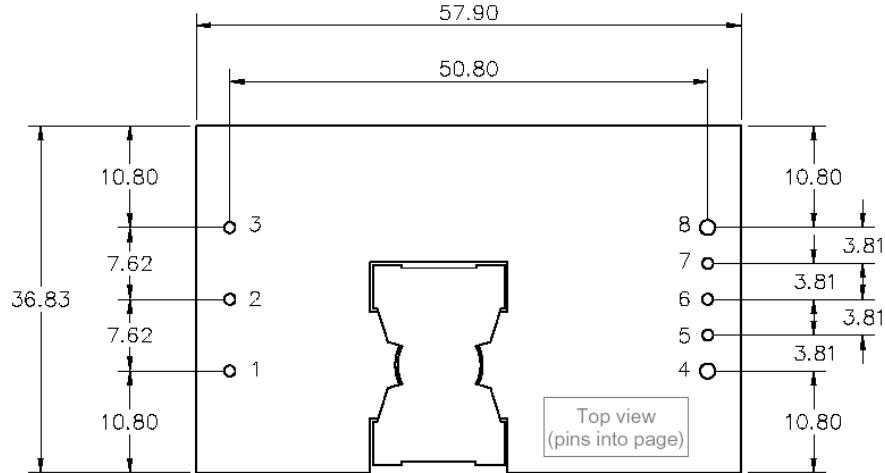

Figure 47. Input Reflected Ripple Current Set-up.

Note: Measure input reflected-ripple current with a simulated inductance (L_{test}) of 12 μ H. Capacitor C_s offsets possible battery impedance. Measure current as shown above.

Mechanical Drawing



| Mechanical Tolerances & Finishes: | | |
|---|----------------------------------|----------------|
| General Dimensions | Millimeters | Inches |
| | X.X = ±0.5 | X.XX = ±0.020 |
| | X.XX ±0.25 | X.XXX = ±0.010 |
| Distance from tallest converter component to host board | 0.25 MIN | 0.010 MIN |
| Pins | | |
| Diameter | ±0.05 | ±0.002 |
| Length | | |
| 4.6mm [0.180"] (suffix -n/a) | ±0.5 | ±.020 |
| 3.68mm [0.145"] (suffix -7) | ±0.5 | ±.020 |
| 2.79mm [0.110"] (suffix -8) | ±0.5 | ±.020 |
| Pin Shoulder | Location | Dimension |
| | Pins 1-3 & 5-7 | 1.80mm dia. |
| | Pins 4 & 8 | 2.1mm dia. |
| Material & Finish | Copper with Tin/Lead over Nickel | |

| Pin Assignments | Function |
|-----------------|----------|
| 1 | -Vin |
| 2 | On/Off |
| 3 | +Vin |
| 4 | -Vout |
| 5 | -Sense |
| 6 | Trim |
| 7 | +Sense |
| 8 | +Vout |

Ordering Information

Example: QMS at 12 V with negative logic, and 3.68mm [0.145"] length pins = QMS07DH-N7

| Series | # Outputs | Io | Vin Range | Vout | - | OPTIONS (Suffixes) | |
|------------------------------|----------------------|-----------------|-------------------------|--------------------------------|---|-------------------------|---|
| | | | | | | On/Off Logic | Pin Length |
| QM | S | 25 | D | E, G, H | - | none, N | none, 7, 8 |
| Series Name [Q = ¼-Brick] | S = Single output | A _{DC} | 18 to 60V _{DC} | E = 3.3 G = 5.0 H = 12.0 | - | None = Pos. N = Neg. | None (Standard) = 4.6mm [0.18"] 7 = 3.68mm [0.145"] 8 = 2.79mm [0.110"] |

RoHS Ordering Information

| Options | Suffixes to Add to Part Number |
|-------------------------------------|---|
| RoHS lead solder exemption | No RoHS character required. |
| RoHS compliant for all 6 substances | Add "G" as the last character of the part number. |

NUCLEAR AND MEDICAL APPLICATIONS - Power-One products are not designed, intended for use in, or authorized for use as critical components in life support systems, equipment used in hazardous environments, or nuclear control systems without the express written consent of the respective divisional president of Power-One, Inc.

TECHNICAL REVISIONS - The appearance of products, including safety agency certifications pictured on labels, may change depending on the date manufactured. Specifications are subject to change without notice.