

#### FEATURES

- HIGH FREQUENCY OPERATION TO 1 GHz
- SELECTABLE DIVIDE RATIO:  $\div 2$ ,  $\div 4$ ,  $\div 8$
- WIDE SUPPLY VOLTAGE RANGE: 2.2 TO 5 V
- LOW SUPPLY CURRENT: 5.3 mA
- SMALL PACKAGE: 8 pin SSOP
- AVAILABLE IN TAPE AND REEL

#### DESCRIPTION

The UPB1509GV is a Silicon MMIC digital prescaler manufactured with the NESAT™ IV silicon bipolar process. It features frequency response to 1 GHz, selectable divide-by-two, four, or eight modes, and operates from a 3 to 5 volt supply while drawing only 5.3 milliamps. The device is housed in a small 8 pin SSOP package that contributes to system miniaturization. The low power consumption and wide supply range makes the device well suited for cellular and cordless telephones as well as DBS receiver applications.

#### TEST CIRCUIT

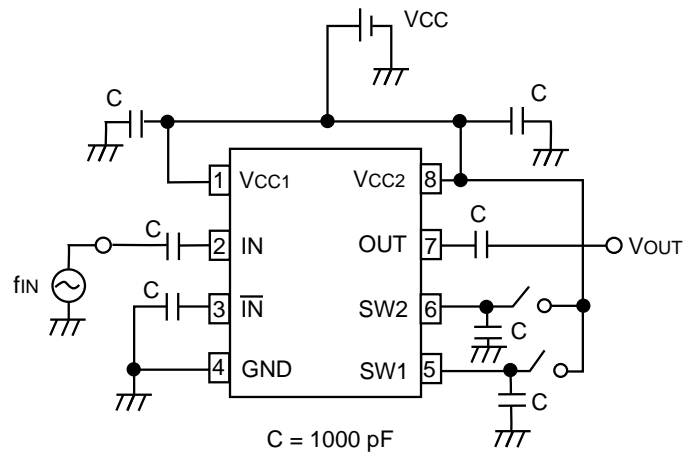

#### ELECTRICAL CHARACTERISTICS (T<sub>A</sub> = -40 to +85°C, V<sub>CC</sub> = 2.2 to 5.5 V, unless otherwise noted)

PART NUMBER PACKAGE OUTLINE			UPB1509GV S08		
SYMBOLS	PARAMETERS AND CONDITIONS	UNITS	MIN	TYP	MAX
I <sub>CC</sub>	Supply Current, No Input Signal, V <sub>CC</sub> = 3 V	mA	2.5	5.0	5.9
f <sub>IN (U)</sub>	Upper Limit Operating Frequency, P <sub>IN</sub> = -20 to 0 dBm P <sub>IN</sub> = -20 to -5 dBm @ $\div 2$ @ $\div 4$ @ $\div 8$	MHz MHz MHz MHz	500 700 800 1000		
f <sub>IN (L)</sub>	Lower Limit Operating Frequency, P <sub>IN</sub> = -20 to 0 dBm P <sub>IN</sub> = -20 to -5 dBm	MHz MHz			50 500
P <sub>IN</sub>	Input Power, f <sub>IN</sub> = 50 to 1000 MHz f <sub>IN</sub> = 50 to 500 MHz	dBm dBm	-20 -20		-5 0
V <sub>OUT</sub>	Output Voltage, R <sub>L</sub> = 200 Ω	V <sub>P-P</sub>	0.1	0.2	
V <sub>IN(H)</sub>	Division Ratio Control Voltage High	V		V <sub>CC</sub>	
V <sub>IN(L)</sub>	Division Ratio Control Voltage Low	V		OPEN	

**ABSOLUTE MAXIMUM RATINGS<sup>1</sup>** (T<sub>A</sub> = 25°C)

SYMBOLS	PARAMETERS	UNITS	RATINGS
V <sub>CC1</sub> , V <sub>CC2</sub>	Supply Voltage	V	6.0
V <sub>IN</sub>	Input Voltage	V	6.0
P <sub>D</sub>	Power Dissipation <sup>2</sup>	mW	250
T <sub>OP</sub>	Operating Temperature	°C	-45 to +85
T <sub>STG</sub>	Storage Temperature	°C	-55 to +150

Notes:

1. Operation in excess of any one of these parameters may result in permanent damage.
2. Mounted on a double-sided copper clad 50x50x1.6 mm epoxy glass PWB (T<sub>A</sub> = +85°C).

**RECOMMENDED OPERATING CONDITIONS**

SYMBOL	PARAMETER	UNITS	MIN	TYP	MAX
V <sub>CC1</sub> , V <sub>CC2</sub>	Supply Voltage	V	2.2	3.0	5.5
T <sub>OP</sub>	Operating Temperature	°C	-40	+25	+85

**PRODUCT LINE-UP**

Product No.	I <sub>CC</sub> (mA)	V <sub>CC</sub> (V)	+2 f <sub>IN</sub> (MHz)	+4 f <sub>IN</sub> (MHz)	+8 f <sub>IN</sub> (MHz)	Package
UPB587G	5.5	2.2 to 3.5	50 to 300	50 to 600	50 to 1000	8 pin SOP
UPB1509GV	5.3	2.2 to 5.5	50 to 1000	50 to 1000	50 to 1000	8 pin SSOP

Note: This table shows Typ. values only.

**INTERNAL BLOCK DIAGRAM**

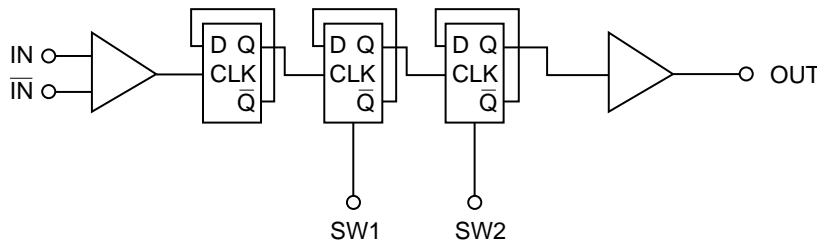

**PIN DESCRIPTIONS**

Pin no.	Symbol	Applied Voltage	Pin Voltage	Description													
1	VCC1	2.2 to 5.5	–	Power supply pin of input amplifier and dividers. This pin must be equipped with bypass capacitor (eg 1000 pF) to ground.													
2	IN	–	1.7 to 4.95	Signal input pin. This pin should be coupled with a capacitor (eg 1000 pF).													
3	IN-bar	–	1.7 to 4.95	Signal input bypass pin. This pin must be equipped with a bypass capacitor (eg 1000 pF) to ground.													
4	GND	0	–	Ground pin. Ground pattern on the board should be formed as wide as possible to minimize ground impedance.													
5	SW1	H/L (VCC/OPEN)	–	Divided ratio control pin. Divide ratio can be controlled by the following input voltages to these pins. <table border="1" style="margin: 10px auto;"> <thead> <tr> <th colspan="2" rowspan="2"></th> <th colspan="2">SW2</th> </tr> <tr> <th>H (Vcc)</th> <th>L (OPEN)</th> </tr> </thead> <tbody> <tr> <th rowspan="2">SW1</th> <th>H (Vcc)</th> <td>1/2</td> <td>1/4</td> </tr> <tr> <th>L (OPEN)</th> <td>1/4</td> <td>1/8</td> </tr> </tbody> </table>			SW2		H (Vcc)	L (OPEN)	SW1	H (Vcc)	1/2	1/4	L (OPEN)	1/4	1/8
		SW2															
		H (Vcc)	L (OPEN)														
SW1	H (Vcc)	1/2	1/4														
	L (OPEN)	1/4	1/8														
6	SW2	H/L (VCC/OPEN)	–	These pins must each be equipped with a bypass capacitor to ground.													
7	OUT	–	1.0 to 4.7	Divided frequency output pin. This pin is designed as an emitter follower output. This pin can output 0.1 V <sub>p-p</sub> min with a 200 Ω load. This pin should be coupled to load device with a capacitor (eg 1000 pF).													
8	VCC2	2.2 to 5.5	–	Power supply pin of output buffer amplifier. This pin must be equipped with bypass capacitor (eg 1000 pF) to ground.													

**TYPICAL PERFORMANCE CURVES**

(TA = +25°C unless otherwise noted)

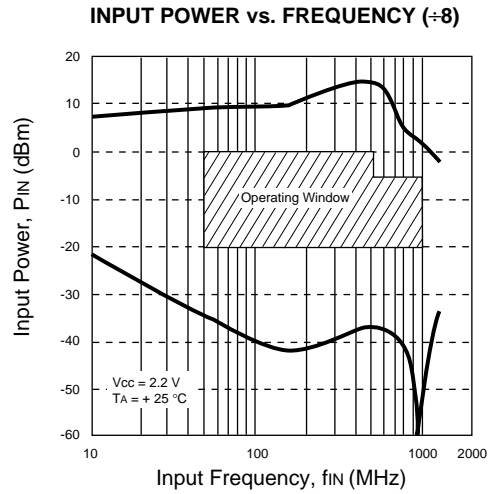
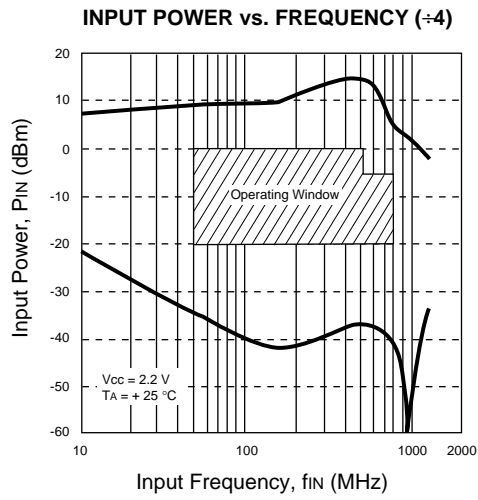
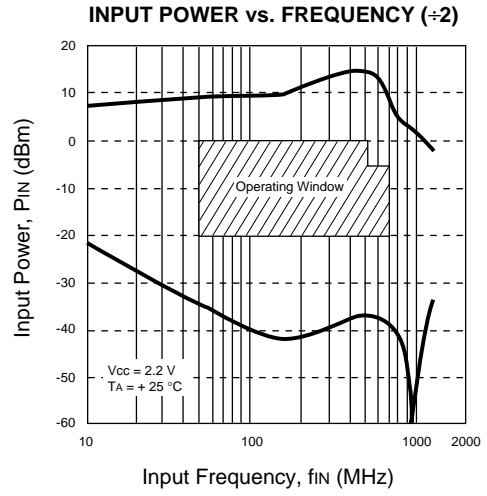
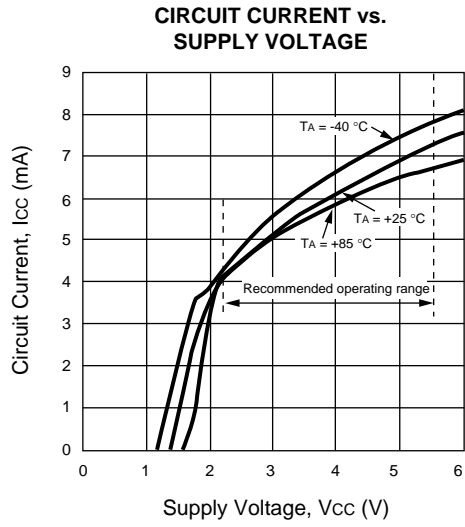

**OUTLINE DIMENSIONS** (Units in mm)

**PACKAGE OUTLINE S08**

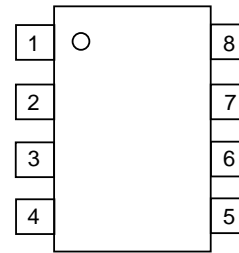
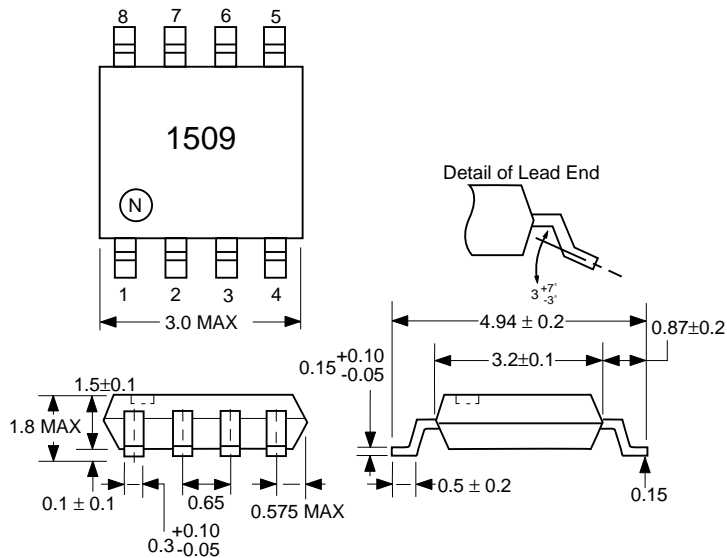

**PIN CONNECTIONS**

- 1. Vcc1
- 2. IN
- 3.  $\overline{\text{IN}}$
- 4. GND
- 5. SW1
- 6. SW2
- 7. OUT
- 8. Vcc2

**ORDERING INFORMATION**

PART NUMBER	QUANTITY
UPB1509GV-E1	1000/Reel

EXCLUSIVE NORTH AMERICAN AGENT FOR **NEC** RF, MICROWAVE & OPTOELECTRONIC SEMICONDUCTORS

**CEL** CALIFORNIA EASTERN LABORATORIES • Headquarters • 4590 Patrick Henry Drive • Santa Clara, CA 95054-1817 • (408) 988-3500 • Telex 34-6393 • FAX (408) 988-0279  
 24-Hour Fax-On-Demand: 800-390-3232 (U.S. and Canada only) • Internet: <http://WWW.CEL.COM>

DATA SUBJECT TO CHANGE WITHOUT NOTICE

PRINTED IN USA ON RECYCLED PAPER -2/97