

VI TELEFILTER**Filter Specification****TFS 400 H****1/5****Measurement condition**

Ambient temperature: 23 °C
 Input power level: 0 dBm
 Terminating impedances *)
 for input : $385 \Omega \parallel -1,05 \text{ pF}$
 for output: $385 \Omega \parallel -1,05 \text{ pF}$
 External coil : 67 nH

Characteristics**Remark:**

Reference level for the relative attenuation a_{rel} of the TFS400H is the minimum of the pass band attenuation a_{min} . The minimum of the pass band attenuation a_{min} is defined as the insertion loss a_e . The centre frequency f_c is the arithmetic mean value of the upper and lower frequencies at the 3 dB filter attenuation level relative to the insertion loss a_e . The nominal frequency f_N is fixed on 400 MHz without tolerance. The given values for the relative attenuation a_{rel} and for the group delay ripple have to be reached at the frequencies given below also if the centre frequency f_c is shifted due to the temperature coefficient of frequency TC_f in the operating temperature range and due to a production tolerance for the centre frequency f_c .

D a t a		typ. value		tolerance/limit		
Insertion loss (Reference level)	$a_e = a_{min}$	3,6	dB	max.	6,5	dB
Nominal frequency	f_N	-			400,000	MHz
Centre frequency	f_c	400,02	MHz			
Usable signal bandwidth		-		min.	140	kHz
3 dB bandwidth	BW	362	kHz		-	
Relative attenuation	a_{rel}					
f_N	$\dots f_N \pm 70 \text{ kHz}$	0,7	dB	max.	3	dB
$f_N \pm 400 \text{ kHz} \dots f_N \pm 600 \text{ kHz}$		25	dB	min.	15	dB
$f_N \pm 600 \text{ kHz} \dots f_N \pm 1 \text{ MHz}$		42	dB	min.	27	dB
$f_N \pm 1 \text{ MHz} \dots f_N \pm 13 \text{ MHz}$		54	dB	min.	35	dB
Group delay ripple	GD					
$f_N \pm 70 \text{ kHz}$		0,4	μs	max.	2	μs
Operating temperature range		-			- 20 °C ... + 70	°C
Storage temperature range		-			- 35 °C ... + 85	°C
Temperature coefficient of frequency	TC	- 0.036	ppm/K ²			
Frequency inversion temperature		+ 20	°C			

*) The terminating impedances depend on parasitics and q-values of matching elements and the board used, and are to be understood as reference values only. Should there be additional questions do not hesitate to ask for an application note or contact our design team.

Generated:**Checked / approved:**

VI TELEFILTER
 Potsdamer Straße 18
 D 14 513 TELTOW / Germany
 Tel: (+49) 3328 4784-0 / Fax: (+49) 3328 4784-30
 E-Mail: tft@telefilter.com

Vectron International Inc.
 267 Lowell Road
 Hudson, NH 03051 / USA
 Tel: (603) 598-0070 Fax: (603) 598-0075
 E-Mail: vti@vtnh.com

VI TELEFILTER reserves the right to make changes to the product(s) and/or information contained herein without notice. No liability is assumed as a result of their use or application. No rights under any patent accompany the sale of any such product(s) or information.

VI TELEFILTER**Filter Specification****TFS 400 H****2/5****Construction, pin configuration and 50 Ω - matching network**

(All dimensions in mm)

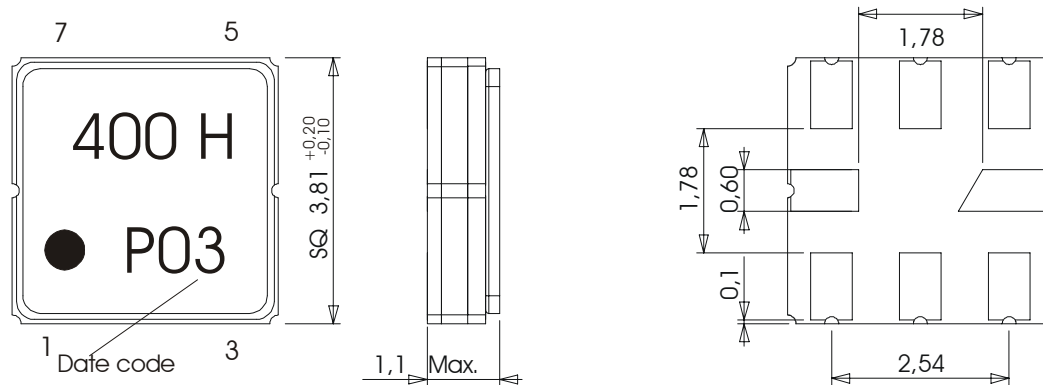

Pin 1 Sym. Output
 Pin 2 Sym. Output
 Pin 3 External Coil
 Pin 4,8 Package Ground

Pin 5 Sym. Input
 Pin 6 Sym. Input
 Pin 7 Ground

Date code: Year + week
 M 2000
 N 2001
 P 2002
 ...

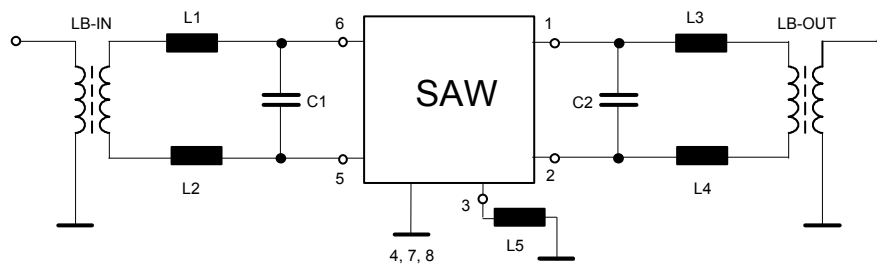
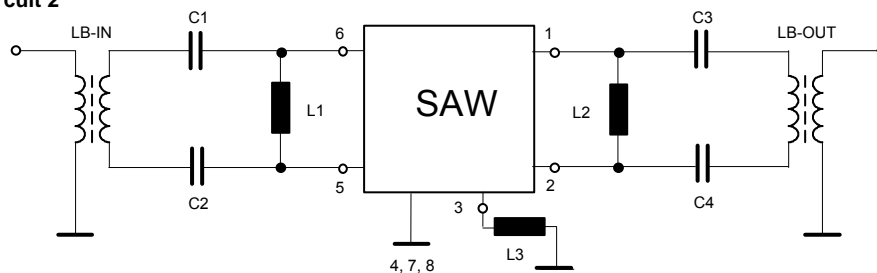
50 Ohm Test circuit 1**50 Ohm Test circuit 2**

VI TELEFILTER
 Potsdamer Straße 18
 D 14 513 TELTOW / Germany
 Tel: (+49) 3328 4784-0 / Fax: (+49) 3328 4784-30
 E-Mail: tft@telefilter.com

Vectron International Inc.
 267 Lowell Road
 Hudson, NH 03051 / USA
 Tel: (603) 598-0070 Fax: (603) 598-0075
 E-Mail: vti@vtnh.com

VI TELEFILTER reserves the right to make changes to the product(s) and/or information contained herein without notice. No liability is assumed as a result of their use or application. No rights under any patent accompany the sale of any such product(s) or information.

Stability Characteristics

After the following tests the filter shall meet the whole specification:

1. Shock: 500g, 18 ms, half sine wave, 3 shocks each plane;
DIN IEC 68 T2 - 27
2. Vibration: 10 Hz to 500 Hz, 0,35 mm or 5g respectively, 1 octave per min, 10 cycles per plan, 3 plans;
DIN IEC 68 T2 - 6
3. Change of temperature: -55 °C to 125°C / 30 min. each / 10 cycles
DIN IEC 68 part 2-14 Test N
4. Resistance to solder heat (reflow): max. 2 times reflow process;
for temperature conditions refer to the attached "Air reflow temperature conditions" on page 4;

Packing

Tape & Reel: IEC 286 - 3, with exception of value for N and minimum bending radius;
tape type II, embossed carrier tape with top cover tape on the upper side;

max. pieces of filters per reel: 3000
Reel of empty components at start: min 300 mm
Reel of empty components at start including leader: min 500 mm
Trailer: min 300 mm

Tape (all dimensions in mm)

W	: 12 ± 0,3
Po	: 4 ± 0,1
Do	: 1,5 + 0,1
E	: 1,75 ± 0,1
F	: 5,5 ± 0,05
G (min)	: 0,75
P2	: 2 ± 0,05
P1	: 8 ± 0,1
D1(min)	: 1,5
Ao	: 4,3 ± 0,1
Bo	: 4,3 ± 0,1
CT	: 9,5 ± 0,1

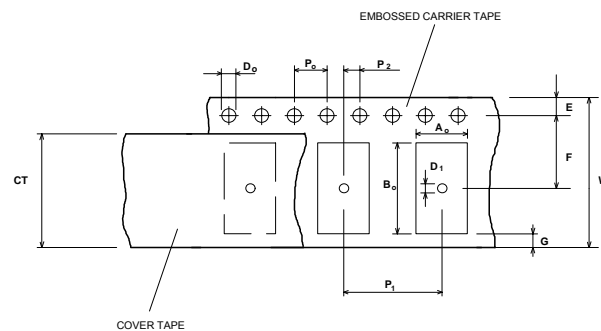
**Reel (all dimensions in mm):**

A	: 330
W1	: 12,4 + 0,2
W2 (max)	: 18,4
N (min)	: 50
C	: 13 + 0,5 / -0,2

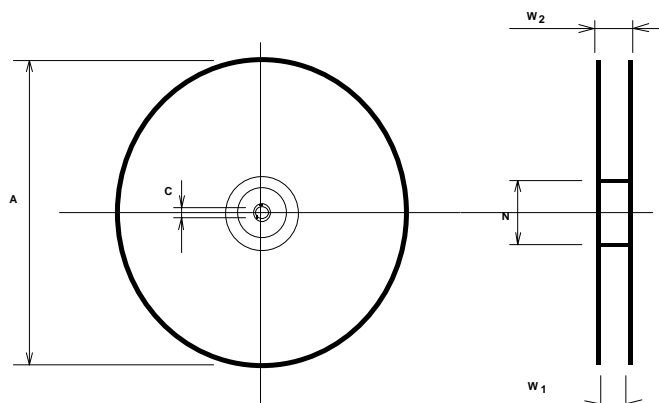

The minimum bending radius is 45 mm. The mounting surface of the filters faces the bottom side of the embossed carrier tape. The marking of the filters is able to read if the view is directed on the upper side of the carrier tape with the sprocket holes on the right side of the tape.

VI TELEFILTER
Potsdamer Straße 18
D 14 513 TELTOW / Germany
Tel: (+49) 3328 4784-0 / Fax: (+49) 3328 4784-30
E-Mail: tft@telefilter.com

Vectron International Inc.
267 Lowell Road
Hudson, NH 03051 / USA
Tel: (603) 598-0070 Fax: (603) 598-0075
E-Mail: vti@vtinh.com

VI TELEFILTER reserves the right to make changes to the product(s) and/or information contained herein without notice. No liability is assumed as a result of their use or application. No rights under any patent accompany the sale of any such product(s) or information.

Air reflow temperature conditions

1st and 2nd air reflow profile

Name:	pre-heating periods	main-heating periods	peak temperature
Temperature:	150 °C - 170 °C	over 200 °C	255 °C ± 5 °C
Time:	60 sec. - 90 sec.	20 sec. - 25 sec.	

Chip-mount air reflow profile

Table for temperature vs. time during the air reflow process

Tolerance of temperatures: ± 5 °C

time / sec.	temperature / °C	time / sec.	temperature / °C
0	23	140	160
10	34	150	161
20	46	160	164
30	60	170	170
40	80	180	180
50	103	190	205
60	121	195	230
70	134	200	255
80	143	205	230
90	150	210	205
100	154	215	180
110	156	220	165
120	158	230	140
130	159	240	120

VI TELEFILTER**Filter Specification****TFS 400 H****5/5****History**

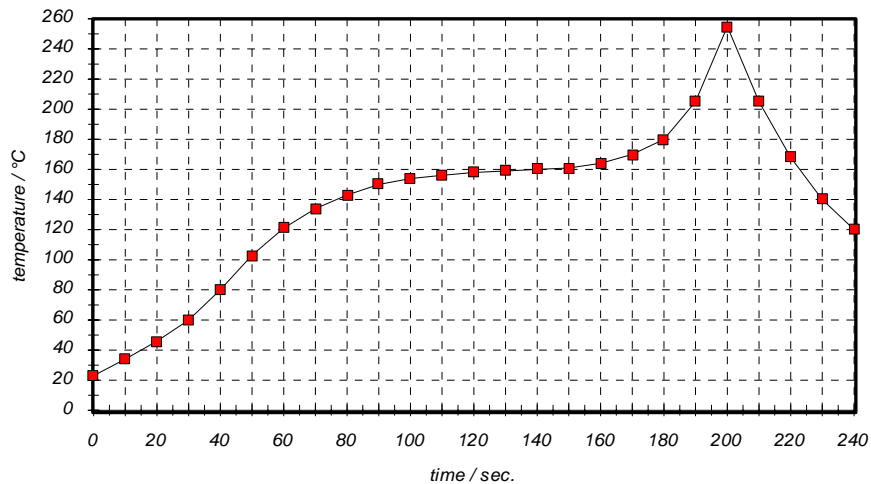
Version	Reason of Changes	Name	Date
1.0	- Generation of specification.	Dr. Wall	15.09.2000
1.1	- Change from development specification to filter specification. - Add termination impedances. - Add typical filter data. - Correct reel information. - Change stability characteristics. - Add pinning to package drawing.	Dr. Wall	08.01.2002

VI TELEFILTER
Potsdamer Straße 18
D 14 513 TELTOW / Germany
Tel: (+49) 3328 4784-0 / Fax: (+49) 3328 4784-30
E-Mail: tft@telefilter.com

Vectron International Inc.
267 Lowell Road
Hudson, NH 03051 / USA
Tel: (603) 598-0070 Fax: (603) 598-0075
E-Mail: vti@vtnh.com

VI TELEFILTER reserves the right to make changes to the product(s) and/or information contained herein without notice. No liability is assumed as a result of their use or application. No rights under any patent accompany the sale of any such product(s) or information.