

**VI TELEFILTER****Filter Specification****TFS 36 D****1/5****1. Measurement condition :**

Ambient temperature  $T_A$ : 23 °C  
 Input power level: 0 dBm.  
 Terminating impedances at  $f_C$  : for input: 50  $\Omega$  | 0 pF.  
 for output: 50  $\Omega$  | 0 pF.

**2. Characteristics :**

Remark:

Reference level for the relative attenuation  $a_{rel}$  of the **TFS 36D** is the minimum of the pass band attenuation  $a_{min}$ . The minimum of the pass band attenuation  $a_{min}$  is defined as the insertion loss  $a_e$ . The centre frequency  $f_C$  is the arithmetic mean value of the upper and lower frequencies at the 40 dB filter attenuation level relative to the insertion loss  $a_e$ . The nominal frequency  $f_N$  is fixed on 36 MHz without tolerance. The temperature coefficient of frequency  $T_C$  is valid both for the reference frequency  $f_C$  and the frequency response of the filter.

Data	typ. value	tolerance / limit
<b>Insertion loss (Reference level) <math>a_e</math></b>	25,9 dB	max. 30 dB
<b>Nominal frequency : <math>f_N</math> at temperature <math>T_{OT} = 45^\circ\text{C}</math></b>	36,0 MHz	36 MHz
<b>Centre frequency <math>f_C</math> at ambient temperature <math>T_A</math> (<math>f_{CAT}</math>)</b>	36,06 MHz	
<b>Pass band (PB) at operating temperature <math>T_{OT} = 45^\circ\text{C}</math> :</b>		$f_N - 2,6 \text{ MHz} \dots f_N + 2,6 \text{ MHz}$
<b>Amplitude ripple in PB (p-p) :</b>	0,45 dB	max. 0,75 dB
<b>Amplitude ripple in any 1 MHz increment within 90% of the PB :</b>	0,35 dB	max. 0,4 dB
<b>Bandwidth at operating temperature <math>T_{OT} = 45^\circ\text{C}</math> :</b>		
0,75 dB - band width	5,80 MHz	min. 5,20 MHz
1 dB - band width	5,90 MHz	min. 5,80 MHz
3 dB - band width	6,17 MHz	
40 dB - band width	7,16 MHz	max. 7,25 MHz
45 dB - band width	7,21 MHz	max. 8,00 MHz
55 dB - band width	7,29 MHz	
<b>Relative attenuation <math>a_{rel}</math></b>		
$f_N \pm 2,6 \text{ MHz} \dots f_N \pm 2,9 \text{ MHz}$	-	max. 0,75 dB max. 1,0 dB
$f_N \pm 3,625 \text{ MHz} \dots f_N \pm 4,0 \text{ MHz}$	55 dB	min. 40 dB
$f_N - 26,0 \text{ MHz} \dots f_N - 4,0 \text{ MHz}$	55 dB	min. 45 dB
$f_N + 4,0 \text{ MHz} \dots f_N + 34,2 \text{ MHz}$	55 dB	min. 45 dB
<b>Group delay ( mean value in PB ):</b>	3,15 $\mu\text{s}$	max. 5,0 $\mu\text{s}$
<b>Group delay ripple in PB (p-p):</b>	50 ns	max. 150 ns
<b>Deviation from linear phase in PB (p-p):</b>	1,8 °	max. 2° p-p
<b>Triple transit attenuation compared to main signal :</b>	61 dB	
<b>Crosstalk :</b>	70 dB	
<b>Temperature coefficient of frequency (<math>T_C</math>)</b>	-75 ppm/K	
<b>Frequency deviation of <math>f_C</math> over temperature</b>	$\Delta f_C(\text{Hz}) = T_C(\text{ppm/K}) \times (T - T_A) \times f_{CAT} (\text{MHz})$	
<b>Operating temperature</b>		+ 45 °C
<b>Storage temperature range</b>		- 25 °C ... + 85 °C

**Generated:****Dunzow W.P.****Checked/Approved:****Dr. Bert Wall**

**VI TELEFILTER**  
 Potsdamer Straße 18  
 D 14 513 TELTOW / Germany  
 Tel: (+49) 3328 4784-0 / Fax: (+49) 3328 4784-30  
 E-Mail: [ftf@telefilter.com](mailto:ftf@telefilter.com)

**Vectron International, Inc.**  
 267 Lowell Road  
 Hudson, NH 03051 / USA  
 Tel: (603) 598-0070 Fax: (603) 598-0075  
 E-Mail: [vti@vtinh.com](mailto:vti@vtinh.com)

VI TELEFILTER reserves the right to make changes to the product(s) and/or information contained herein without notice. No liability is assumed as a result of their use or application. No rights under any patent accompany the sale of any such product(s) or information.

**3. Package :**

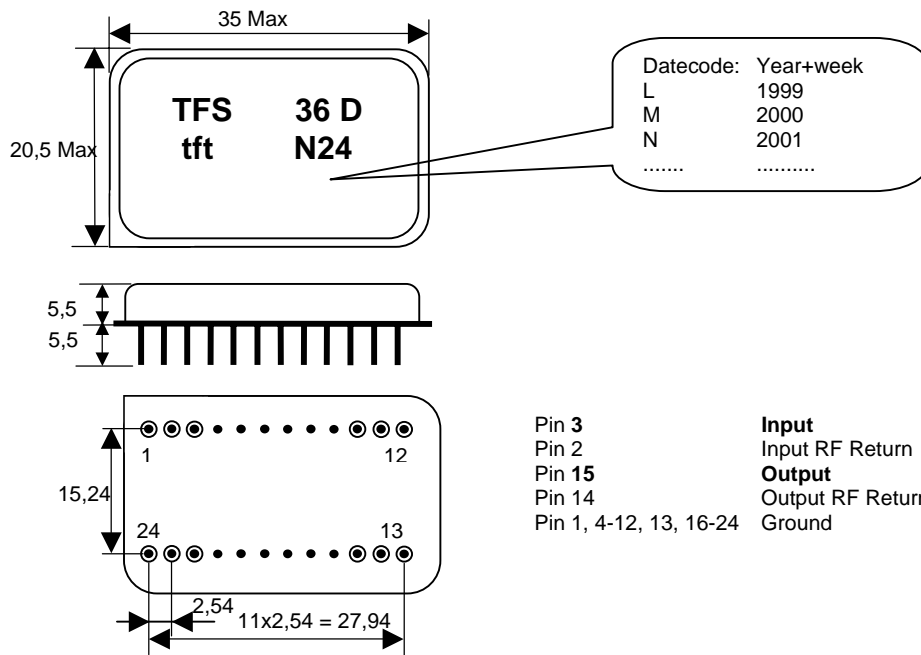

**4. 50 Ω matching network :**

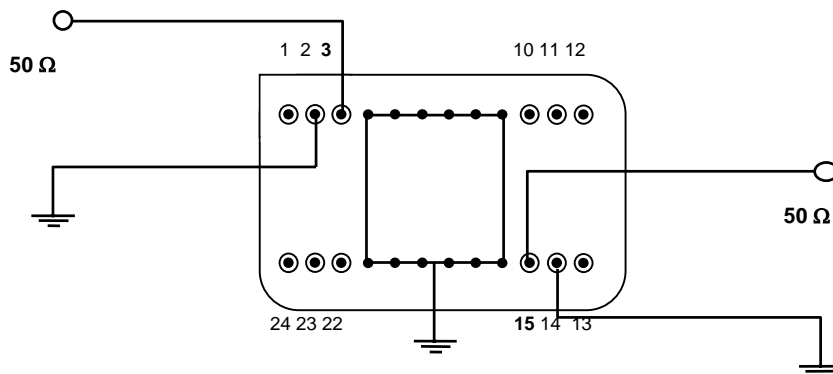

**5. Stability characteristics :**

After the following tests the filter shall meet the whole specification:

1. Shock: 500g, 18 ms, half sine wave, 3 shocks each plane;  
DIN IEC 68 T2 - 27
2. Vibration: 10 Hz to 500 Hz, 0,35 mm or 5g respectively, 1 octave per min, 10 cycles per plan, 3 plans;  
DIN IEC 68 T2 - 6
3. Change of temperature -55 °C to 125°C / 30 min. each / 10 cycles  
DIN IEC 68 part 2 – 14 Test N
4. Resistance to solder heat (reflow):max. 2 times reflow process;  
for temperature conditions refer to the attached "Air reflow temperature conditions" on page 4;

## 6. Air reflow temperature conditions :

1st and 2nd air reflow profile

Name:	pre-heating periods	main-heating periods	peak temperature
Temperature:	150 °C - 170 °C	over 200 °C	255 °C ± 5 °C
Time:	60 sec. - 90 sec.	20 sec. - 25 sec.	

### Air reflow profile

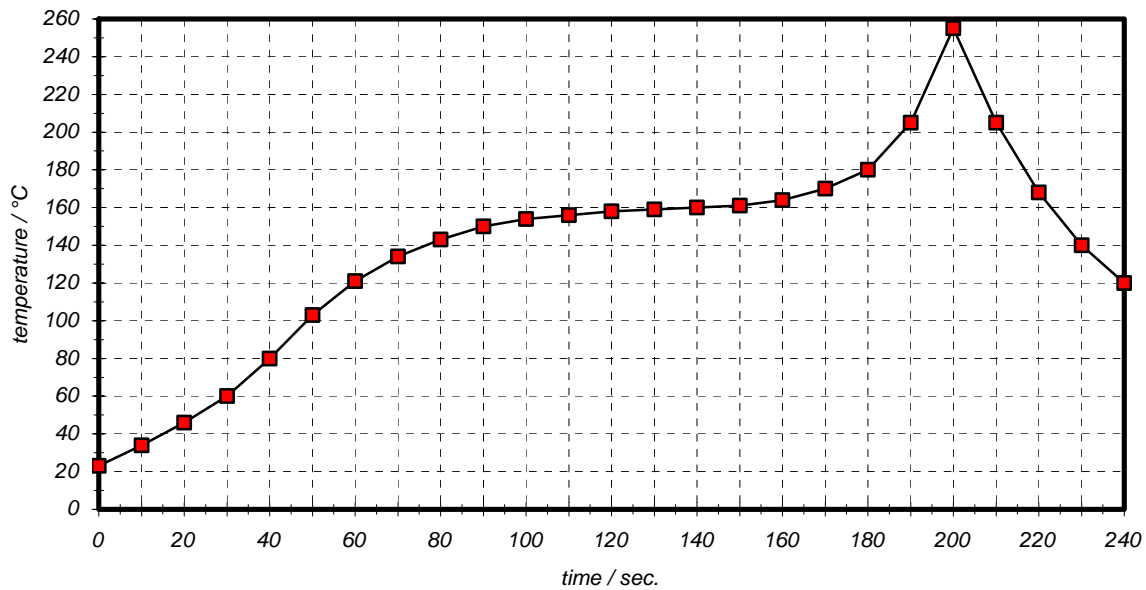

Table for temperature vs. time during the air reflow process

Tolerance of temperatures: ± 5 °C

time / sec.	temperature / °C	time / sec.	temperature / °C
0	23	140	160
10	34	150	161
20	46	160	164
30	60	170	170
40	80	180	180
50	103	190	205
60	121	195	230
70	134	200	255
80	143	205	230
90	150	210	205
100	154	215	180
110	156	220	165
120	158	230	140
130	159	240	120

**VI TELEFILTER****Filter Specification****TFS 36 D****5/5****7. History :**

<b>Version</b>	<b>Reason of Changes</b>	<b>Name</b>	<b>Date</b>
1.0	- generate specification according to customer requirements.	Pfeiffer	14.06.2001
1.1	- amplitude ripple in passband added. - relative attenuation $f_N \pm 2,60$ MHz changed to max. 0,75 dB	Pfeiffer	26.06.2001
1.2	- change operating temperature : from T = 40°C to T = 45°C . - add amplitude ripple in any 1 MHz increment within 90% of the PB .	Dunzow W.	11.07.2001
1.3	- change from development specification to filter specification. - add typical values.	Dunzow W.	20.09.2001

**VI TELEFILTER**  
**Potsdamer Straße 18**  
**D 14 513 TELTOW / Germany**  
**Tel: (+49) 3328 4784-0 / Fax: (+49) 3328 4784-30**  
**E-Mail: [ftf@telefilter.com](mailto:ftf@telefilter.com)**

**Vectron International, Inc.**  
**267 Lowell Road**  
**Hudson, NH 03051 / USA**  
**Tel: (603) 598-0070 Fax: (603) 598-0075**  
**E-Mail: [vti@vtinh.com](mailto:vti@vtinh.com)**

VI TELEFILTER reserves the right to make changes to the product(s) and/or information contained herein without notice. No liability is assumed as a result of their use or application. No rights under any patent accompany the sale of any such product(s) or information.