

LLNS-3T08-H

Narrow Spot Beam

High efficiency lens for LZC emitters



Key Features

- + 8 degree beam angle designed specifically for LED Engin LZC-00xx00 emitter series
- + LLNS-3T08-H lens provides the highest quality and quantity of light in a beam
- + Maximum lux on target
- + Smooth light gradient eliminates hot spots and rings for superior intensity uniformity
- + Lens is available standard with holder that mount easily to LuxiGen LZC MCPCBs
- + UL-rated optical grade PMMA lens material allows use of high current and temperature conditions
- + Simple fastening of holder to PCB with appropriate adhesive, e.g. epoxy or polyurethane based

Typical Applications

- + Down lighting
- + Architectural Lighting
- + Entertainment
- + Stage and Studio Lighting
- + Accent Lighting

Description

The proprietary 8° narrow spot lens couples with the compact, high flux density LZC (12 die) LuxiGen emitter opening up new applications in stage and studio, architectural and down lighting. The TIR lens collimates the LED light into efficient, well-controlled light beams that maximize the usable lumens in the target area. Not only does this lighting solution provide the throw or distance required for these lighting applications, it does so with a smooth, high quality beam of superior intensity uniformity, color over angle mixing, and with an absence of discomfort glare or shadows. In addition, the 8° narrow spot lenses coupled with the LZC 12-die, multi-color RGB, RGBA and RGBW emitters provide excellent in-source color mixing for dynamic color entertainment and architectural lighting applications.

Optical Specification

	Beam angle FWHM ¹	Field angle ²	Optical efficiency ³	On axis intensity ⁴
Part number	degrees	degrees	%	Cd/lm
LLNS-3T08-H	8°	18°	90	12

Notes:

1. Beam angle is defined as the full width at 50% of the max intensity.
2. Field angle is defined as the full width at 10% of the max intensity.
3. Optical efficiency is defined as the ratio between the incoming flux and the outgoing flux.
4. On axis intensity is defined as the ratio between the total input lumen and the intensity in the optical center of the lens.

Typical Relative Intensity over Angle

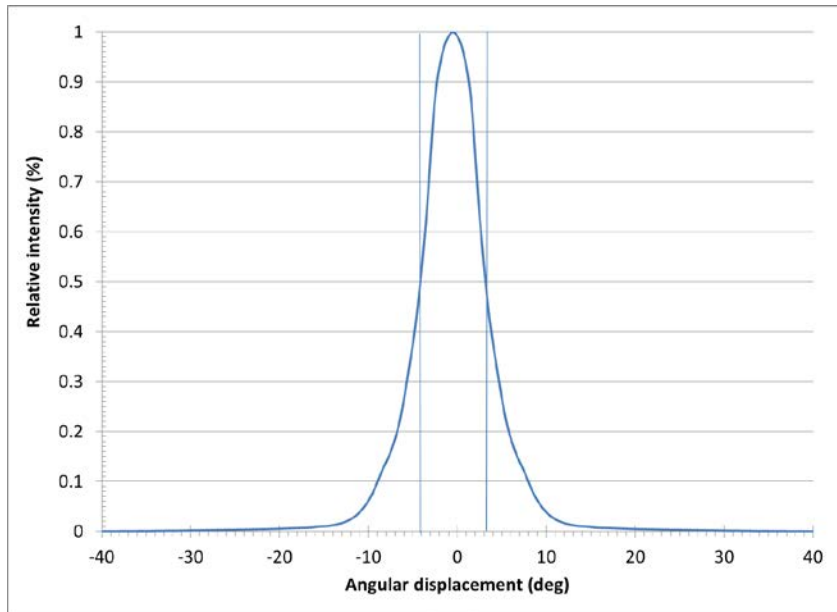

LLNS-3T08-H

General Characteristics

	Symbol	Value	Rating	Unit
Mechanical				
Width holder		84.0	Typical	mm
Height holder		50.5	Typical	mm
Material				
lens		PMMA		
holder		Polycarbonate		
Optical				
Transmittance ¹ (>95%)	λ	410-900	Min-Max.	nm
Environmental				
Storage Temperature	T_{stg}	-40 ~ +110	Min-Max.	°C
Operating Temperature	T_{sol}	-40 ~ +110	Min-Max.	°C

Notes:

1. It is not recommended to use the LZP UV emitter with the LLSP-3T11-H lens due to lower transmittance at wavelengths < 410nm. However the lens can be made of a special material for UV transmittance. Please contact LED Engin for more information.

Mechanical dimensions

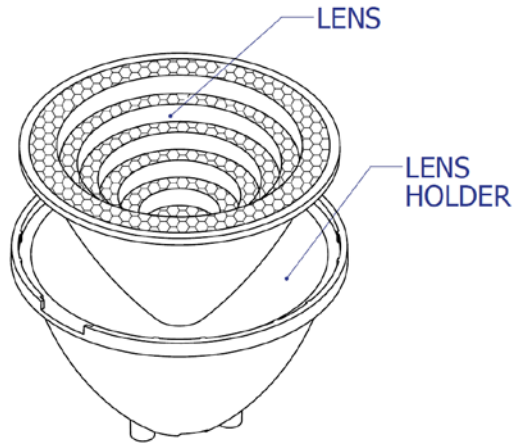

Lens with holder

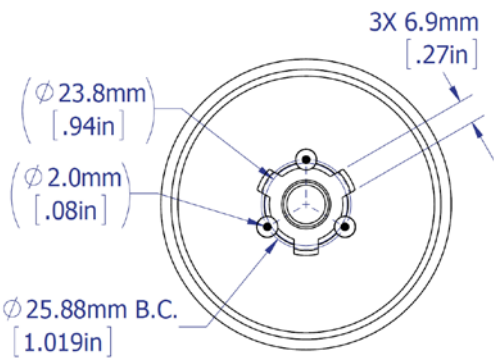
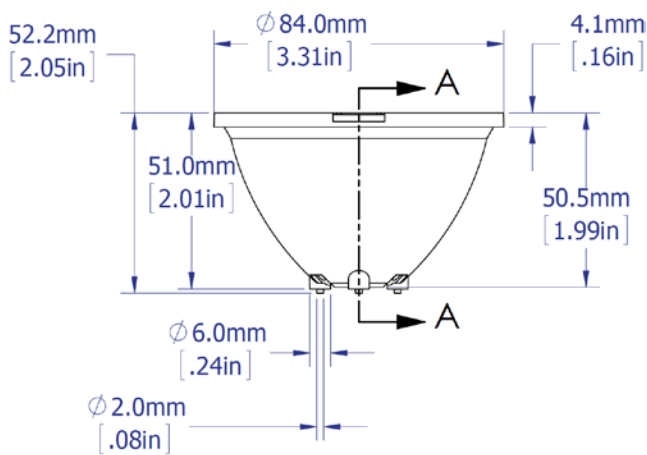

Lens

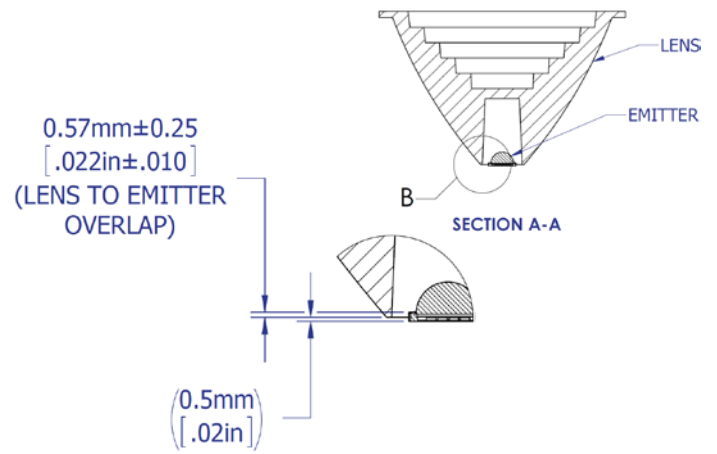
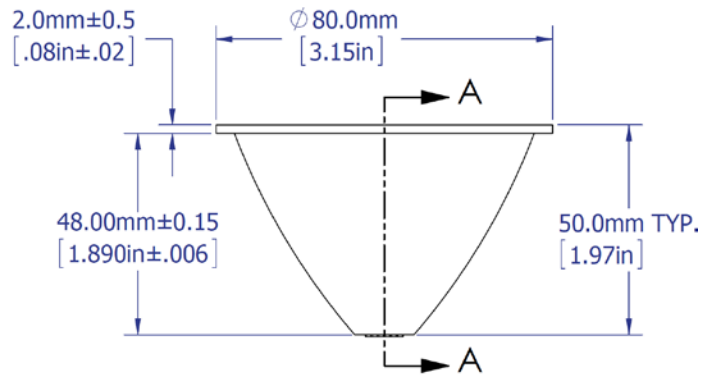

DETAIL B
SCALE 2 : 1

Assembly instruction

Lens holders can be assembled to the PCB by using an epoxy or polyurethane-based adhesive (example; Dow Corning 3145 RTV).

Cyanoacrylate (superglue) adhesive should not be used to avoid contamination of the lens (blooming of the epoxy).

When integrating the lens into a fixture without the lens holder, special attention needs to be placed on maintaining the distance between the lens bottom and the emitter top. Variation in this distance will result in variation of the beam profile. See mechanical detail B. on previous page.

Lens Cleaning

Use a lint free soft cloth to dust off the lens. For deeper cleaning a solution of neutral detergent (like, dishwashing soap) can be used. Do not use any solvents or abrasive liquate/ fabric.

Company Information

LED Engin, based in California's Silicon Valley, specializes in ultra-bright, ultra compact solid state lighting solutions allowing lighting designers & engineers the freedom to create uncompromised yet energy efficient lighting experiences. Our LuxiGen™ Platform — an emitter and lens combination or integrated module solution, delivers superior flexibility in light output, ranging from 3w to 90w, a wide spectrum of available colors, including whites, multi-color and UV, and the ability to deliver upwards of 5,000 high quality lumens to a target. The small size, yet remarkably powerful output, allows for a previously unobtainable freedom of design wherever high-flux density, directional light is required.

LedEngin reserves the right to make changes to improve performance without notice.

Please contact Sales@ledengin.com or (408) 492-0620 for more information.