

RoHS  
Compliant  
Drawing For  
Reference Only

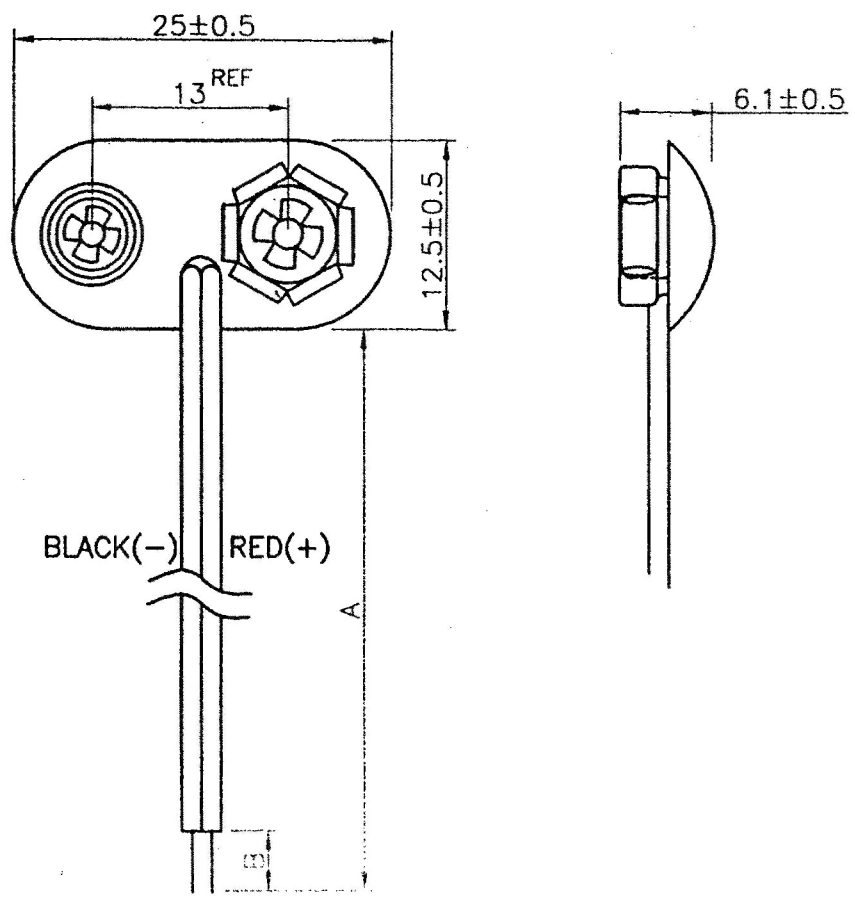

**SPECIFICATION**

- (1) ITEM NO.: BS-701TB(FC)
- (2) WIRE: UL1007 AWG#26  
BLACK & RED A:  
STRIP & TIN B:
- (3) WITH 6 PRONG SNAP TERMINAL
- (4) MATERIAL: P.V.C. COVER, BLACK COLOUR

Technical requirement :

1. This product should meet EU RoHS related requirement.
2. The surface of plastic part should be without any crackle such as burr,lack,and so on phenomenon.
3. The surface of metal part should be without any defect such as scaur,nick,oxidation and plating problem.
4. The electronic performance should be the same as spec.
5. The un-specified tolerance is : <math> < 6 \pm 0.2 </math>  
   <math> 6 \sim 20 \pm 0.3 </math>  
   <math> > 20 \pm 0.4 </math>

<b>DCI DRAGON CITY INDUSTRIES LIMITED</b>			Design	K.W Law	Remark	Scale
			Drawing	W.K Yeung	Remark	Material
Item Name	BATTERY SNAP	Tolerance :	Check	K.L Wong	Remark	Drawing No. A407021445
Item No.	BS-701TB(FC)	Unit : mm	Approval	K.W Chan	Remark	Sheet