

NO	DESCRIPTION	MATERIAL	Q'TY	FINISH
1	SHELL	BRASS	1	NICKEL
2	BODY	BRASS	1	NICKEL
3	INSULATION	DELRIN	1	DELRIN
4	PIN	BRASS	1	NICKEL
5	RING	BRASS	1	NICKEL

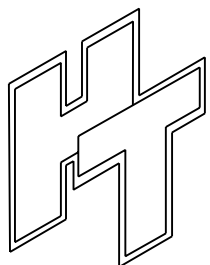
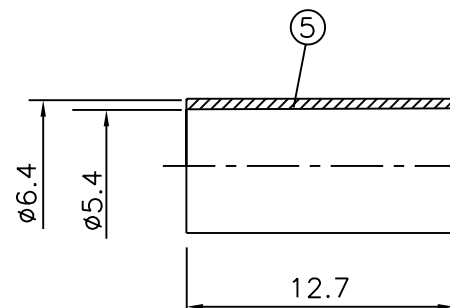
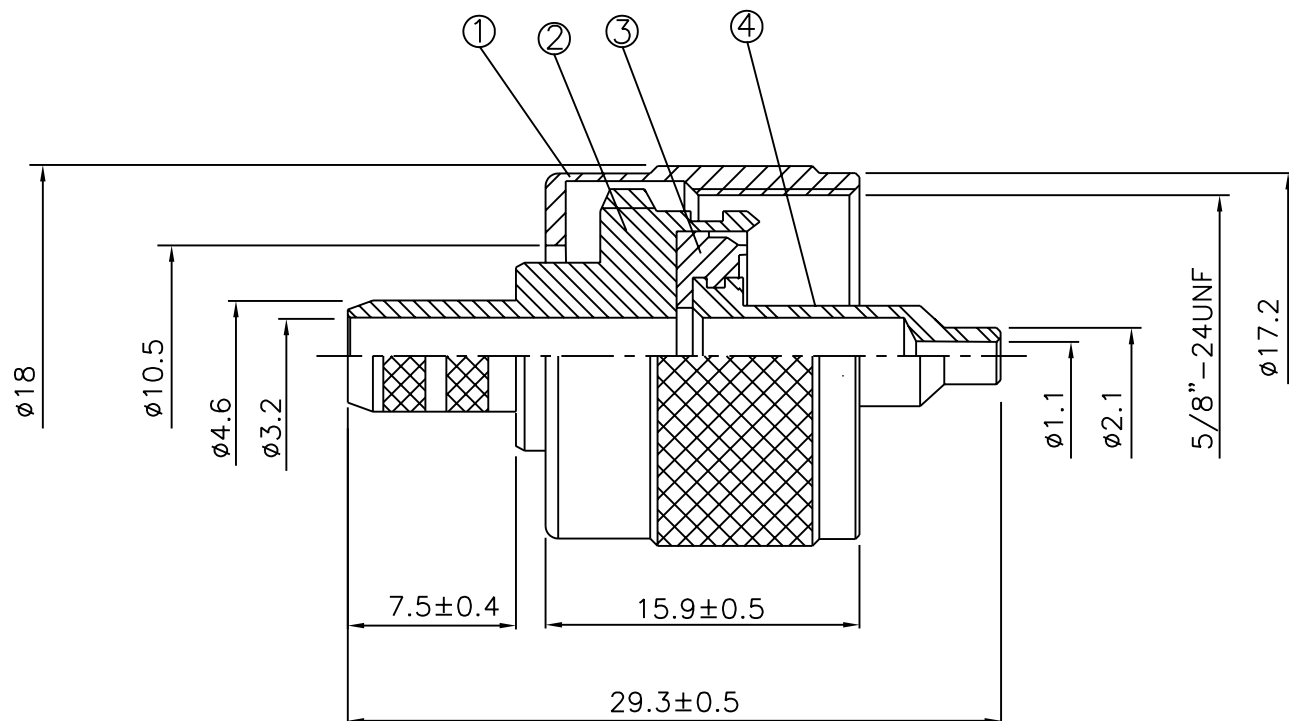
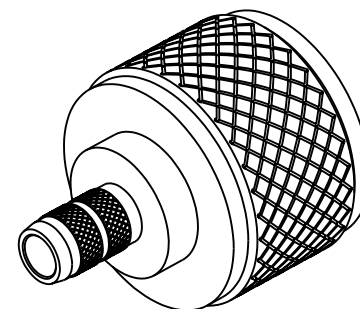

**HUS-TSAN GROUP CO., LTD.**  
P.O. BOX 40-76. TAINAN. TAIWAN, R.O.C.  
**TITLE MALE CRIMP**  
**RG58U, 58A/U, 141A/U**  
**PART NO. UHF-04F-DNN**  
**DRAWING NO. UHF 04F DNN**

DRAWN MARY DATE 96.03.22  
CHECKED 蘇姿潔 DATE  
Q.A. 馮健華 DATE  
APPROVAL 徐燦霖 DATE  
REVISION DATE

**DIMENSIONS ARE IN MILLIMETERS**  
**UNLESS OTHERWISE SPECIFIED TOLERANCE**  
0.5-5 =  $\pm 0.2$     120-315 =  $\pm 1$   
5-30 =  $\pm 0.4$     315-1000 =  $\pm 1.6$   
30-120 =  $\pm 0.6$     1000-2000 =  $\pm 2.4$   
**SCALE 4:1**    **SIZE A**

**REVISION**

DESCRIPTION	ENGINEER