

NO	DESCRIPTION	MATERIAL	Q'TY	FINISH
1	HOUSING	PBT	1	WHITE
2	BODY	BRASS	1	NICKEL
3	INSULATION	TEFLON	1	TEFLON
4	PIN	BRASS	1	GOLD
5	GROUNDING	COPPER	1	TIN
6	WASHER	BRASS	1	NICKEL
7	NUT	BRASS	1	NICKEL

D

C

B

A

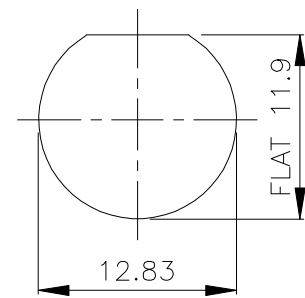
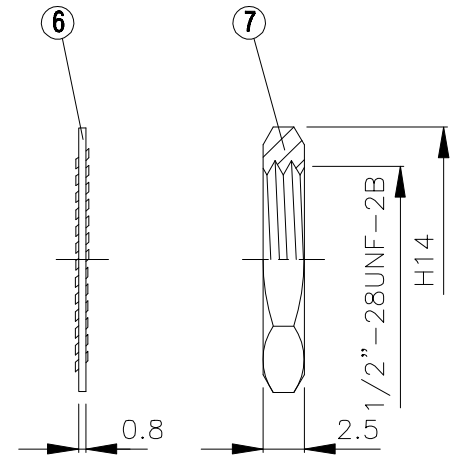
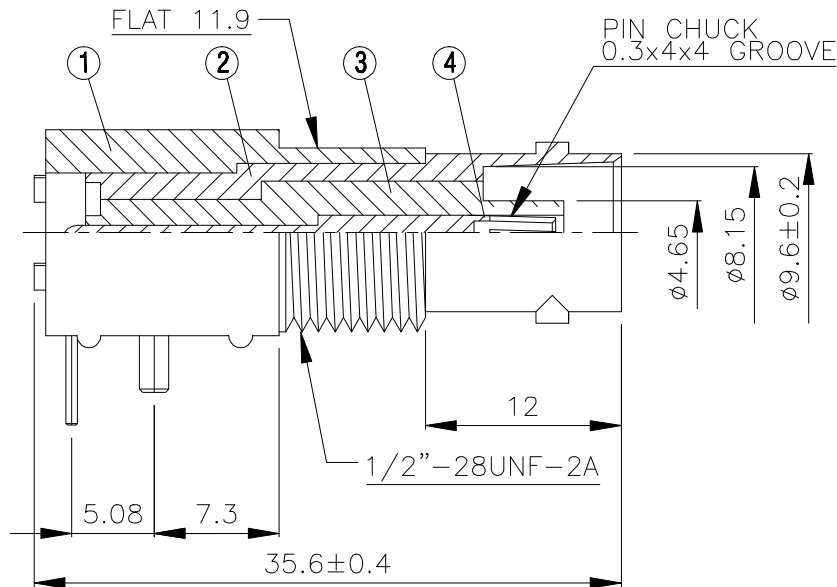
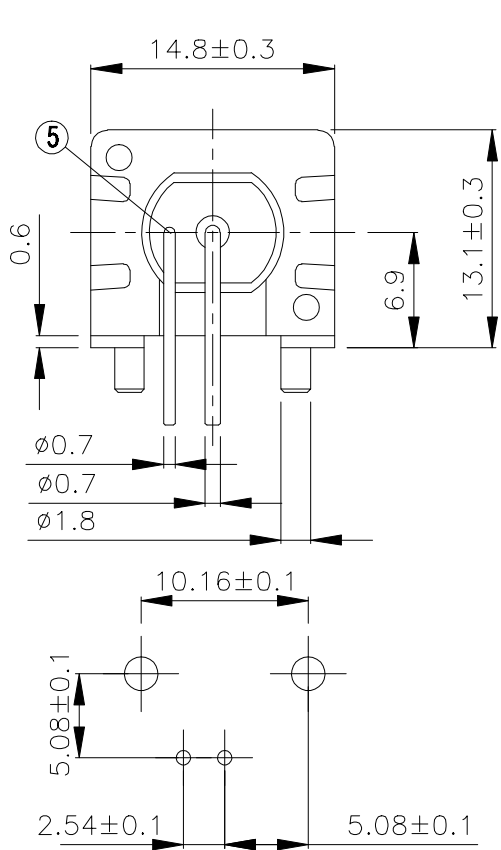

D

C

B

A

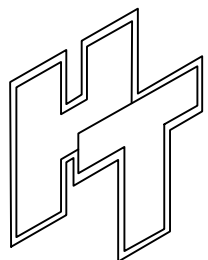

HUS-TSAN GROUP CO., LTD.

P.O. BOX 40-76. TAINAN. TAWAN, R.O.C.

TITLE BNC RIGHT ANGLE FEMALE PCB RECEPTACLE

PART NO. BNC-16-DGN

DRAWING NO. BNC 16 DGN

DRAWN MARY DATE 96.08.14

CHECKED 蘇志欣 DATE

Q.A. 蘇姿潔 DATE

APPROVAL 徐燦霖 DATE

REVISION DATE

DIMENSIONS ARE IN MILLIMETERS

UNLESS OTHERWISE SPECIFIED TOLERANCE

0.5-5=±0.2 120-315=±1

5-30=±0.4 315-1000=±1.6

30-120±0.6 1000-2000=±2.4

SCALE 4:1 SIZE A

REVISION

DESCRIPTION	ENGINEER

4

3

2

1