

NO	DESCRIPTION	MATERIAL	Q'TY	FINISH	REMARK
1	BODY 1	BRASS	1	NICKEL	B-TNC1027-N
2	BODY 2	BRASS	1	NICKEL	B-BNC0115-N
3	INSULATION	DELRIN	1	TEFLON	I-0168T
4	GASKET	RUBBER	1	RUBBER	RU-0006
5	PIN	BRASS	1	GOLD	P-BNC0291-G
6	WASHER	BRASS	1	NICKEL	W-0001-N
7	NUT	BRASS	1	NICKEL	N-0003-N
8	RING	BRASS	1	NICKEL	R-0011-N
9	INSULATION	DELRIN	1	DELRIN	I-0187D

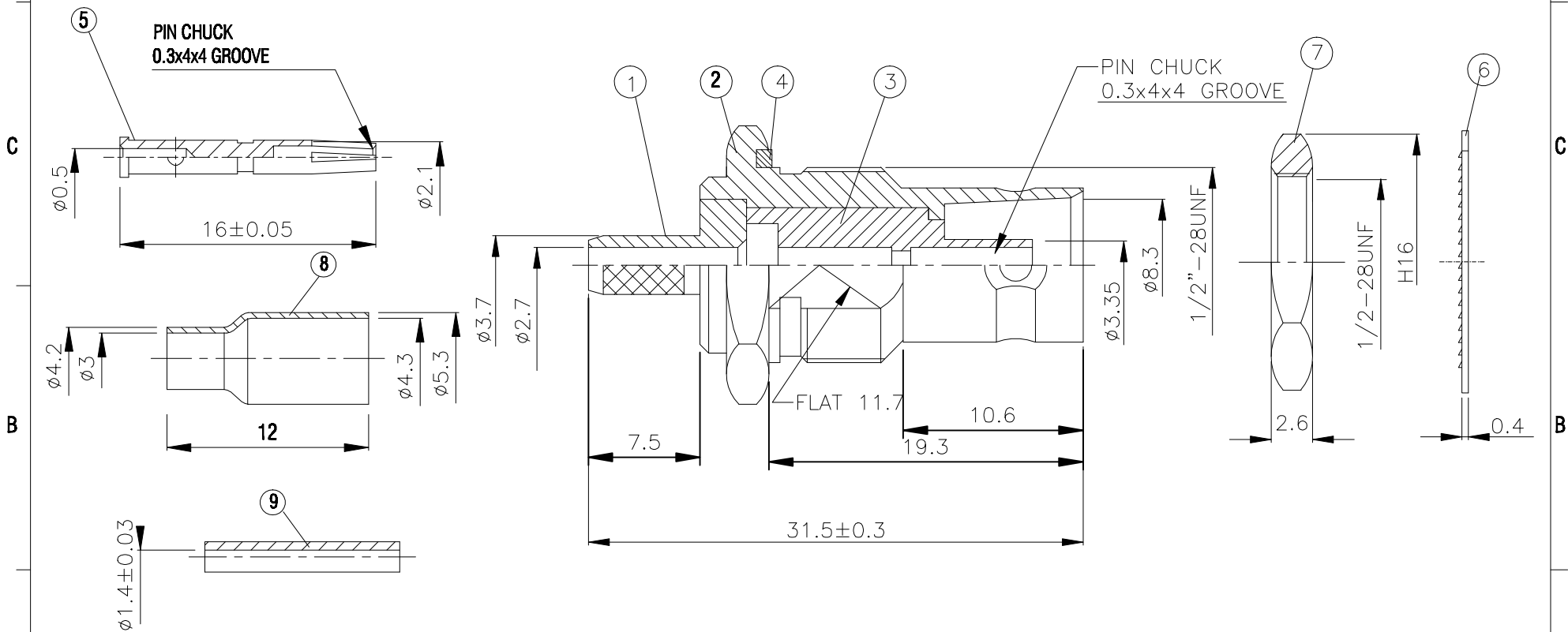
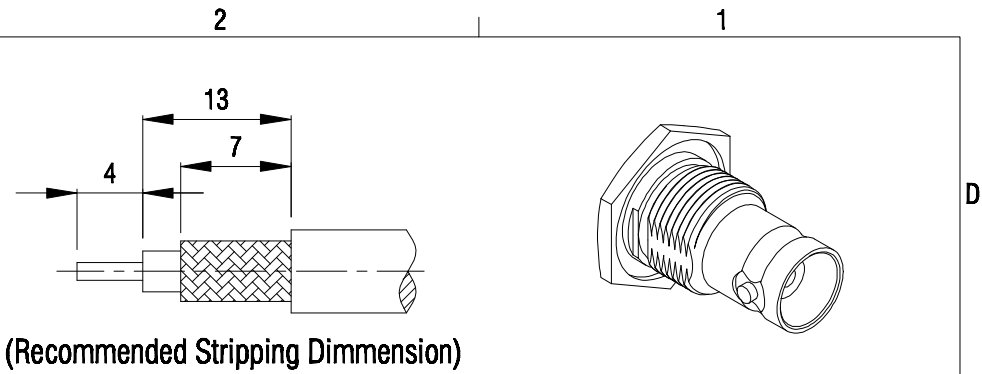

	HUS-TSAN GROUP CO., LTD P.O. BOX 40-76.TAINAN TAIWAN,R.O.C.		DRAWN MARY DATE 96.06.13	DIMENSIONS ARE IN MILLIMETERS		REVISION	
	TITLE BNC FEMALE CRIMP FOR RG-179/U		CHECKED 蘇志欣 DATE	UNLESS OTHERWISE SPECIFIED TOLERANCES		DESCRIPTION	ENGINEER
	PART NO. BNC-06N-TGN		APPROVAL 蘇姿潔 DATE	0.5-5=±0.2 120-315=±1			
	DRAWING NO. BNC 06N TGN		REVISION 徐燦霖 DATE	5-30=±0.4 315-1000=±1.6			
				30-120=±0.6 1000-2000=±2.4	SCALE 4:1	SIZE A	

4 3 2 1