

NO	DESCRIPTION	MATERIAL	Q'TY	FINISH
1	SHELL	BRASS	1	NICKEL
2	BODY 1	BRASS	1	NICKEL
3	GASKET	SI RUBBER	1	RUBBER
4	WASHER	BRASS	1	NICKEL
5	SPRING	SK-5	1	NICKEL
6	WASHER	BRASS	1	NICKEL
7	INSULATION	PTFE	1	PTFE
8	PIN	BRASS	1	GOLD
9	BODY 2	BRASS	1	NICKEL
10	WASHER	BRASS	1	NICKEL
11	INSULATION	TEFLON	1	TEFLON
12	RING	BRASS	1	NICKEL

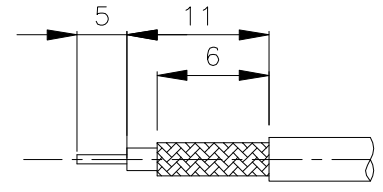

(Recommended Stripping Dimension)

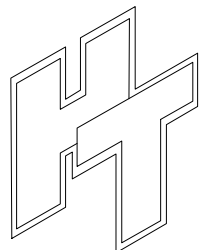
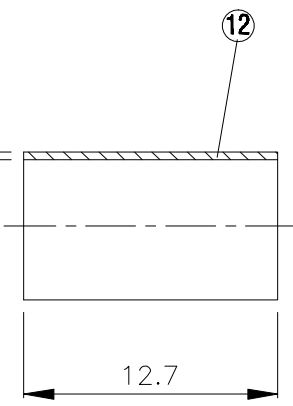
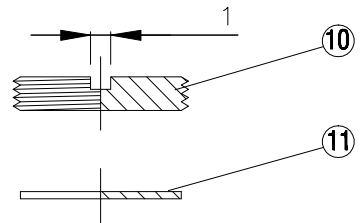
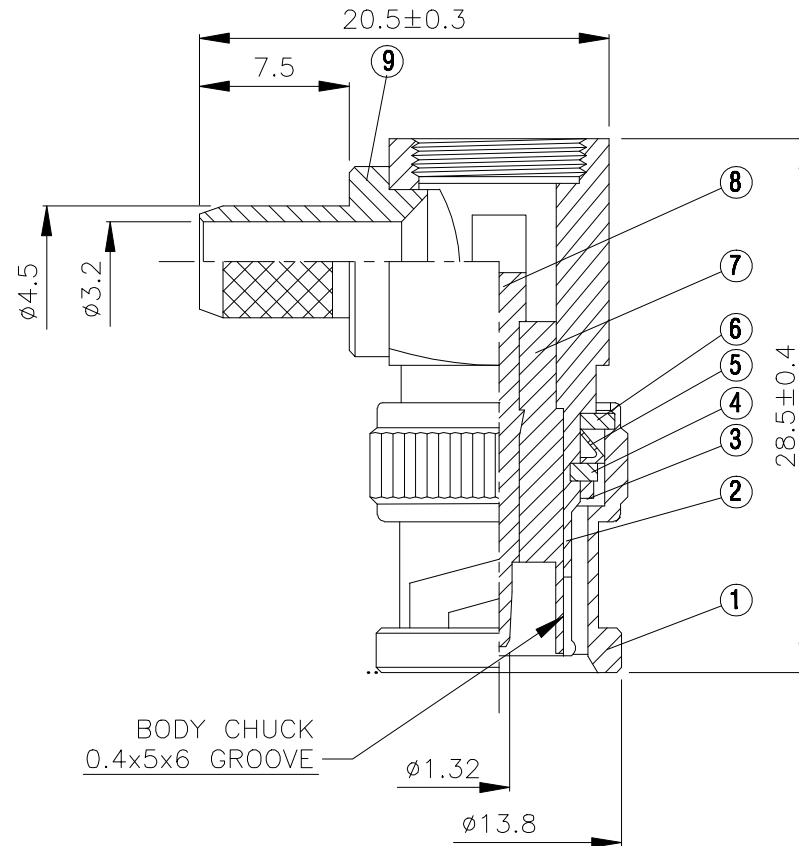
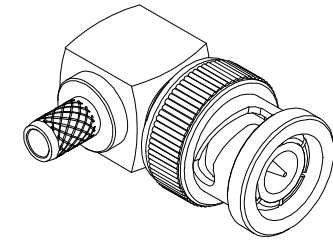

HUS-TSAN GROUP CO., LTD.

P.O.BOX 40-76.TAINAN.TAIWAN,R.O.C.

TITLE **BNC MALE ANGLE CRIMP FOR RG58U,58A/U,141A/U**

PART NO. **BNC-02FV1-TGN**

DRAWING NO. **BNC 02FV1 TGN**

DRAWN	MARY	DATE	96.07.24
CHECKED	蘇志欣	DATE	
Q.A.	蘇姿潔	DATE	
APPROVAL	徐燦霖	DATE	
REVISION		DATE	

DIMENSIONS ARE IN MILLIMETERS			
UNLESS OTHERWISE SPECIFIED TOLERANCE			
0.5-5=±0.2	120-315=±1		
5-30=±0.4	315-1000=±1.6		
30-120=±0.6	1000-2000=±2.4		
SCALE	4:1	SIZE	A

REVISION	
DESCRIPTION	ENGINEER