

| NO | DESCRIPTION | MATERIAL | Q'TY | FINISH | REMARK |
|----|-------------|----------|------|--------|-------------|
| 1 | NUT | BRASS | 1 | NICKEL | N-0006 |
| 2 | WASHER | BRASS | 1 | NICKEL | W-0016 |
| 3 | INSULATION | TEFLON | 1 | TEFLON | I-0131T |
| 4 | BODY | BRASS | 1 | NICKEL | B-SMA0505-N |
| 5 | PIN | BRASS | 1 | GOLD | P-SMA0058-G |
| 6 | RING | BRASS | 1 | NICKEL | R-0007 |

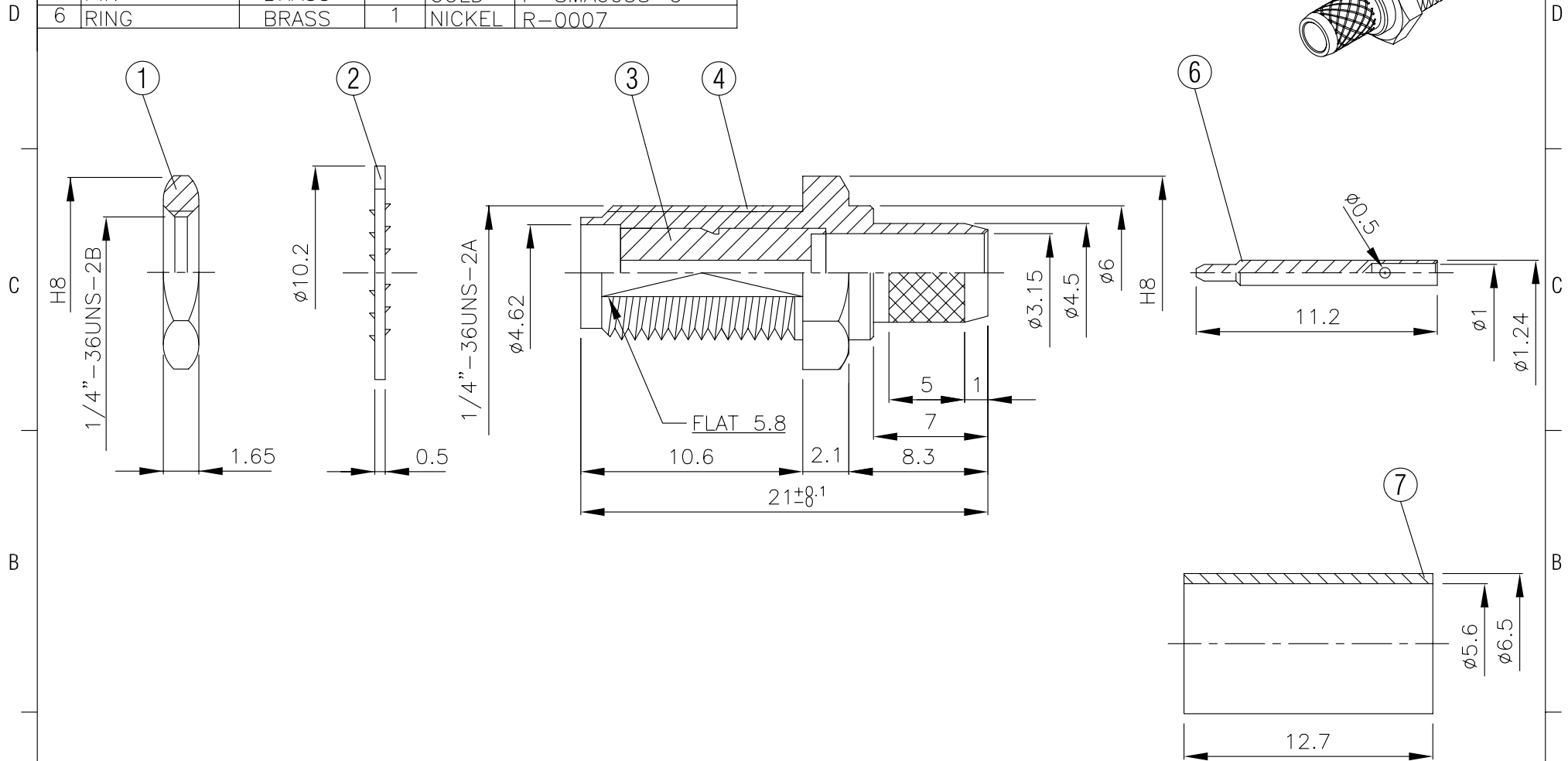
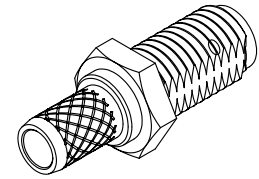

| | | | | | | | |
|--|-----------------------------------------------------------------------|--|-----------------------------|-----------------------------------------|----------------|-------------|----------|
| | HUS-TSAN GROUP CO., LTD. P.O.BOX 40-76.TAINAN.TAIWAN,R.O.C. | | DRAWN MARY DATE 96.06.27 | DIMENSIONS ARE IN MILLIMETERS | | REVISION | |
| | TITLE SMA FEMALE CRIMP FOR RG 58/U REVERSE POLARITY | | CHECKED 蘇志欣 DATE | UNLESS OTHERWISE SPECIFIED TOLERANCE | | DESCRIPTION | ENGINEER |
| | PART NO. SMA-56F-TGN-RP | | Q.A. 蘇姿潔 DATE | 0.5-5=±0.2 | 120-315=±1 | | |
| | DRAWING NO. SMA 56F TGN-RP | | APPROVAL 徐燦霖 DATE | 5-30=±0.4 | 315-1000=±1.6 | | |
| | | | REVISION DATE | 30-120±0.6 | 1000-2000=±2.4 | | |
| | | | SCALE 4:1 | SIZE A | | | |