

NO	DESCRIPTION	MATERIAL	Q'TY	FINISH	REMARK
1	BODY	BRASS	1	NICKEL	B-SMA0314-N
2	PIN	BRASS	1	GOLD	P-SMA0190-G
3	INSULATION	TEFLON	1	TEFLON	I-0149T
4	WASHER	BRASS	1	NICKEL	W-0016-N
5	NUT	BRASS	1	NICKEL	N-0006-N

D

C

B

A

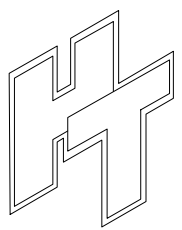
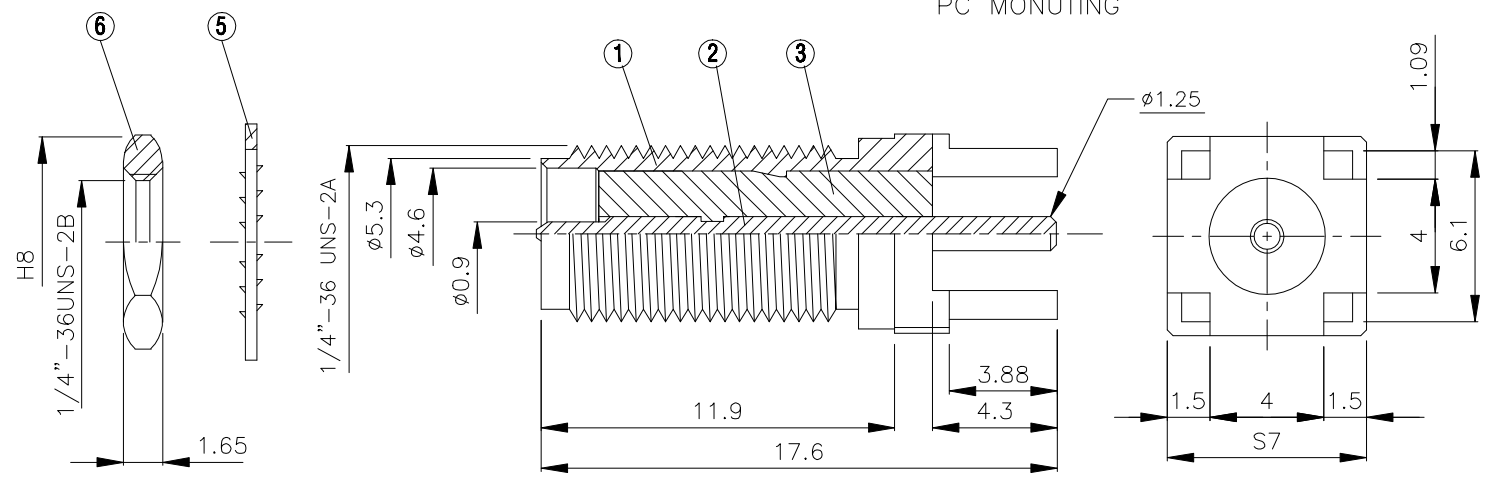
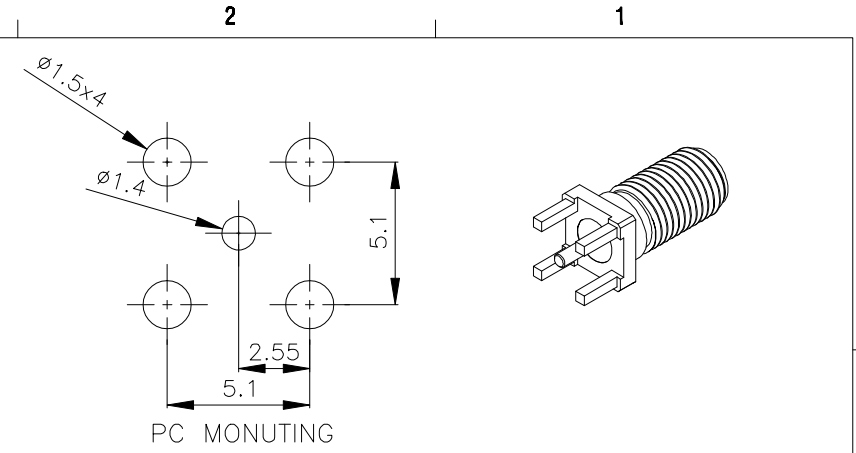

HUS-TSAN GROUP CO., LTD.
 P.O.BOX 40-76.TAINAN.TAIWAN,R.O.C.
TITLE SMA FEMALE PCB MOUNT REVERSE POLARITY
PART NO. SMA-10V23-TGN-RP
DRAWING NO. SMA 10V23 TGN RP

DRAWN MARY **DATE** 96.06.27
CHECKED 蘇志欣 **DATE** 97.07.02
Q.A. 蘇姿潔 **DATE**
APPROVAL 徐燦霖 **DATE**
REVISION **DATE**

DIMENSIONS ARE IN MILLIMETERS
UNLESS OTHERWISE SPECIFIED TOLERANCE
 0.5-5=±0.2 120-315=±1
 5-30=±0.4 315-1000=±1.6
 30-120±0.6 1000-2000=±2.4
SCALE 4:1 **SIZE** A

REVISION	
DESCRIPTION	ENGINEER

4

3

2

1

D

C

B

A