

NO	DESCRIPTION	MATERIAL	Q'TY	FINISH	REMARK
1	NUT	BRASS	1	NICKEL	N-0006
2	WASHER	BRASS	1	NICKEL	W-0016
3	GASKET	SI RUBBER	1	RUBBER	RU-0014
4	INSULATION	TEFLON	1	TEFLON	I-0563T
5	BODY	BRASS	1	NICKEL	B-SMA0205-N
6	PIN	BRASS	1	GOLD	P-SAM0804-G
7	INSULATION	TEFLON	1	TEFLON	I-0229T
8	BODY	BRASS	1	NICKEL	B-SMA0473-N

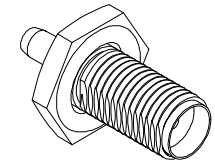

(Recommended Stripping Dimension)

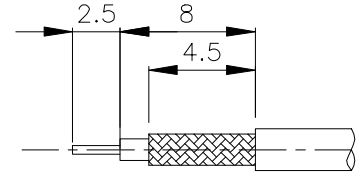
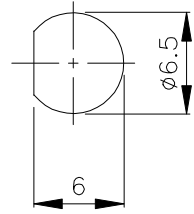
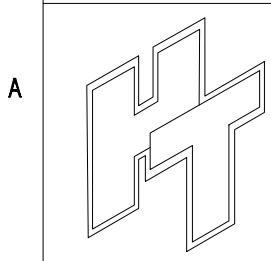
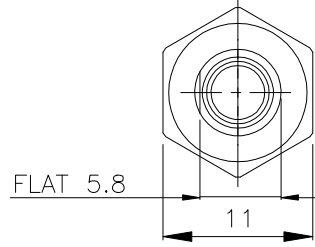
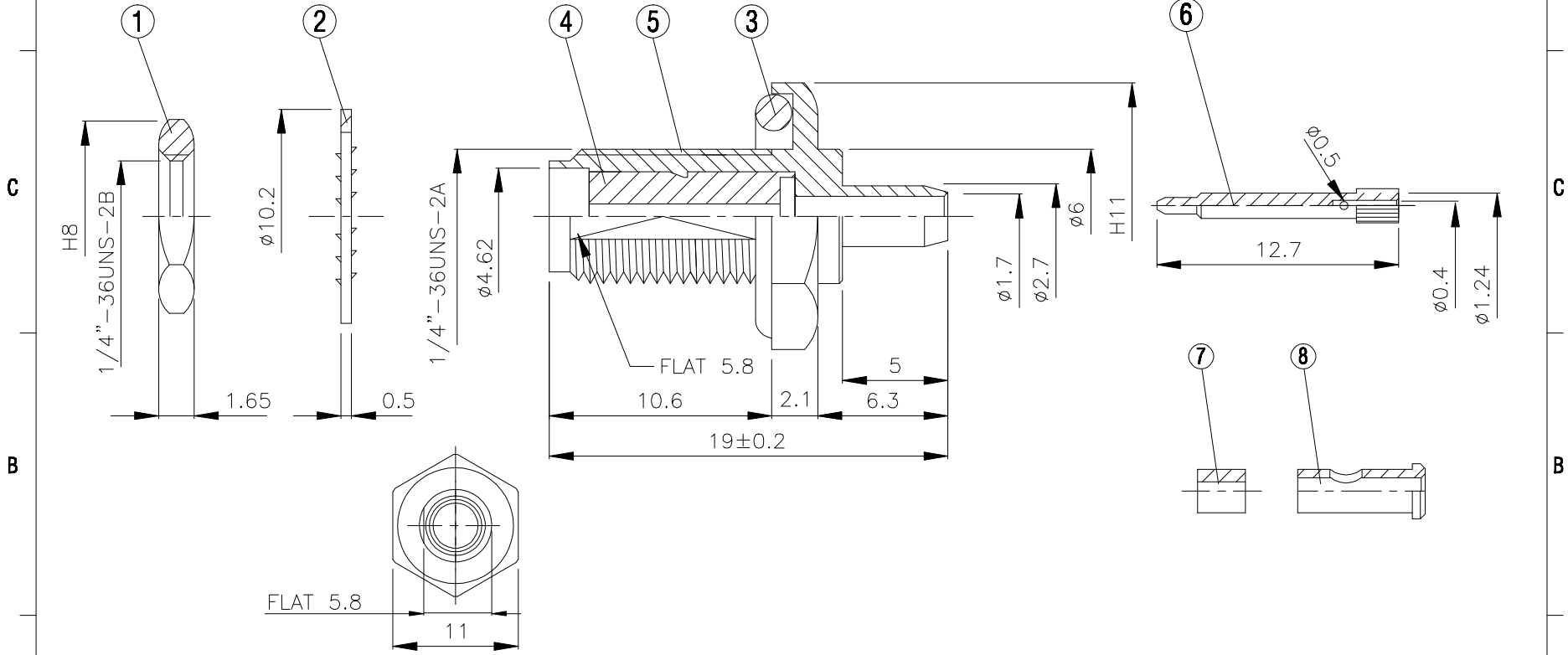

HUS-TSAN GROUP CO., LTD.
P.O.BOX 40-76.TAINAN.TAIWAN,R.O.C.
TITLE SMA FEMALE CRIMP REVERSE POLARITY FOR 178/U
PART NO. SMA-05M-TGN-RP
DRAWING NO. SMA 05M TGN RP

DRAWN MARY **DATE 96.01.18**
CHECKED 蘇姿潔 **DATE**
Q.A. 馮健華 **DATE**
APPROVAL 徐燦霖 **DATE**
REVISION **DATE**

DIMENSIONS ARE IN MILLIMETERS
UNLESS OTHERWISE SPECIFIED TOLERANCE
0.5-5=±0.2 120-315=±1
5-30= ±0.4 315-1000=±1.6
30-120=±0.6 1000-2000=±2.4
SCALE 4:1 **SIZE A**

REVISION	
DESCRIPTION	ENGINEER

4

3

2

1

A

A