

NO	DESCRIPTION	MATERIAL	Q'TY	FINISH	REMARK
1	BODY	BRASS	1	NICKEL	B-SMA0062-N
2	INSULATION	TEFLON	1	TEFLON	I-0547T
3	PIN	BRASS	1	GOLD	P-SMA0040-G
4	RING	BRASS	1	GOLD	R-0002-G

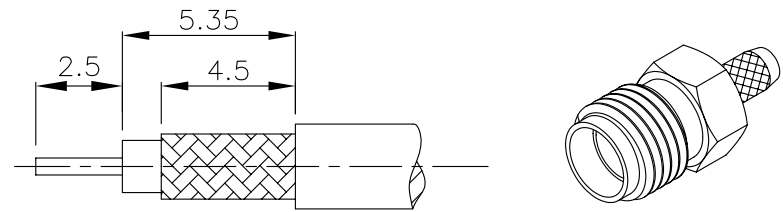

(Recommended Stripping Dimension)

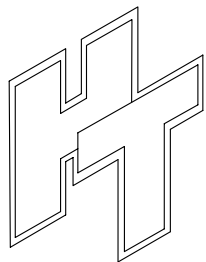
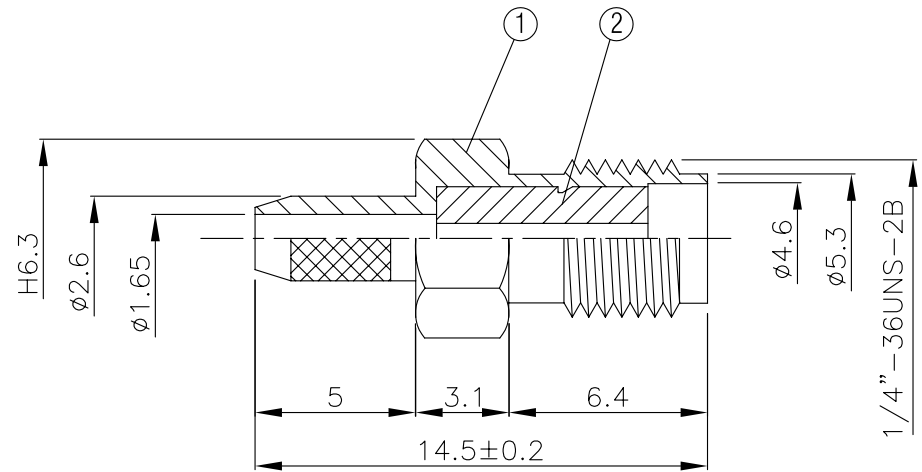
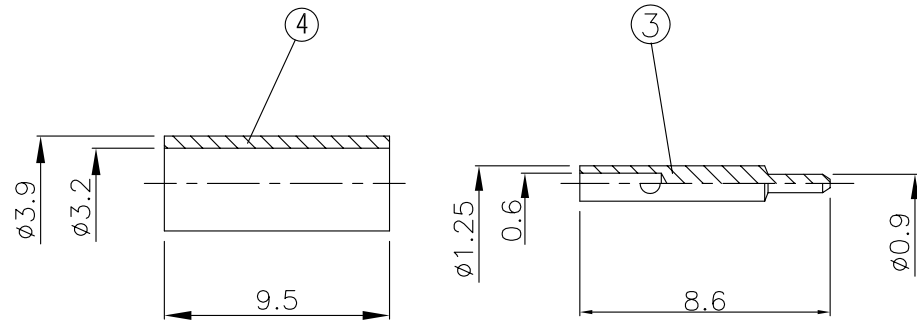

HUS-TSAN GROUP CO., LTD.

P.O. BOX 40-76.TAINAN TAIWAN,R.O.C.

TITLE SMA FEMALE CRIMP FOR
174/U,316/U REVERSE POLARITY

PART NO. SMA-04LV1-TGN-RP

DRAWING NO. SMA 04LV1 TGN RP

DRAWN MARY DATE 96.01.04

CHECKED 黃巧君 DATE

Q.A. 蘇姿潔 DATE

APPROVAL 徐燦霖 DATE

REVISION DATE

DIMENSIONS ARE IN MILLIMETERS

UNLESS OTHERWISE SPECIFIED
TOLERANCES

0.5-5= ± 0.2 120-315= ± 1

5-30= ± 0.4 315-1000= ± 1.6

30-120= ± 0.6 1000-2000= ± 2.4

SCALE 4:1 SIZE A

REVISION

DESCRIPTION	ENGINEER

A