

NO	DESCRIPTION	MATERIAL	Q'TY	FINISH	REMARK
1	SHELL	BRASS	1	NICKEL	B-SMA0043-N
2	GASKET	SI RUBBER	1	RUBBER	RU-0008
3	INSULATION	TEFLON	1	TEFLON	I-0115T
4	WASHER	PH.BRONZE	1	NICKEL	W-0012
5	BODY	BRASS	1	NICKEL	B-SMA0046-N
6	PIN	BE CU	1	GOLD	P-SMA0038-G
7	RING	BRASS	1	NICKEL	R-0007-N

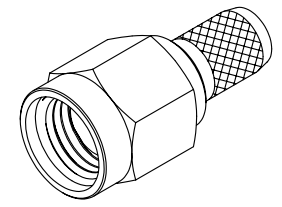

(Recommended Stripping Dimmension)

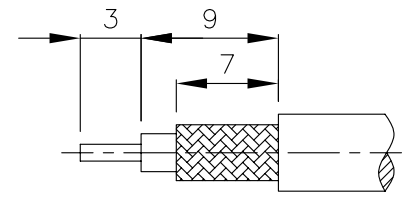
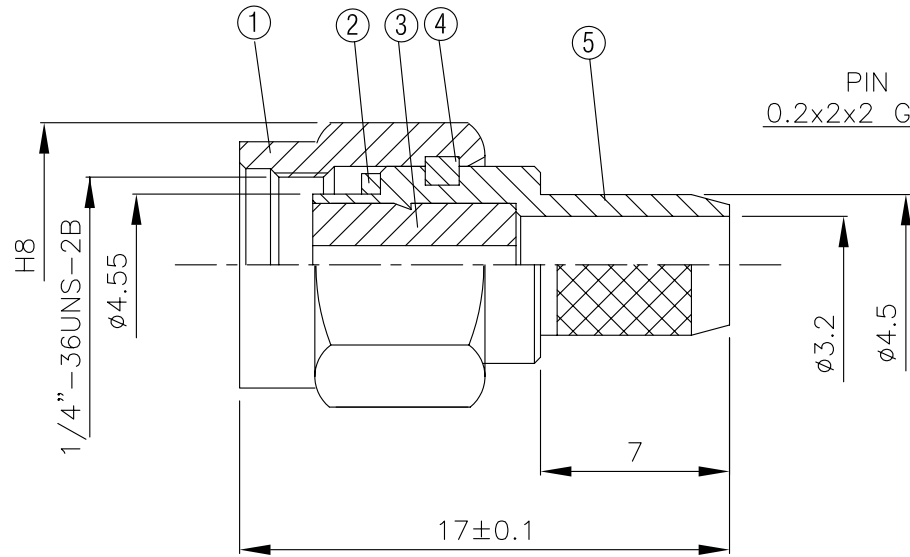

PIN CHUCK  
0.2x2x2 GROOVE

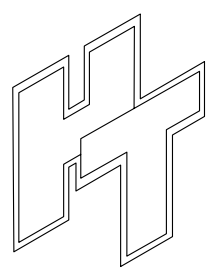
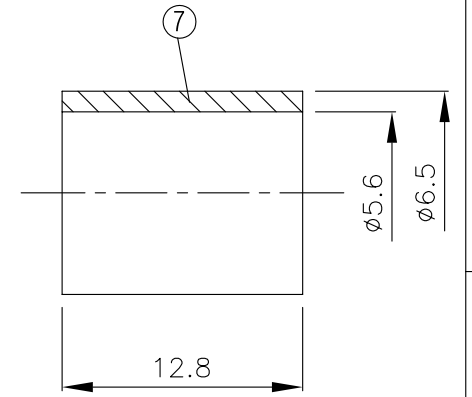
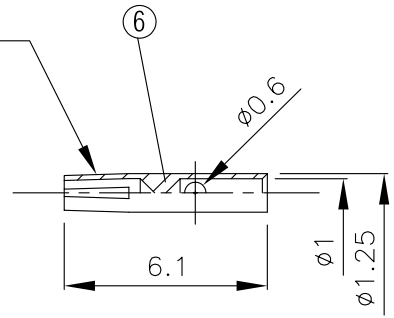

**HUS-TSAN GROUP CO., LTD.**  
P.O.BOX 40-76.TAINAN.TAIWAN,R.O.C.  
TITLE SMA MALE CRIMP FOR RG58/U REVERSE POLARITY  
PART NO. SMA-03F-TGN-RP  
DRAWING NO. SMA-03F-TGN-RP

DRAWN MARY DATE 90.01.25  
CHECKED 蘇志欣 DATE 97.05.02  
Q.A. 蘇姿潔 DATE  
APPROVAL 徐燦霖 DATE  
REVISION DATE

DIMENSIONS ARE IN MILLIMETERS  
UNLESS OTHERWISE SPECIFIED TOLERANCE  
0.5-5=±0.2 120-315=±1  
5-30=±0.4 315-1000=±1.6  
30-120±0.6 1000-2000=±2.4  
SCALE 4:1 SIZE A

REVISION	
DESCRIPTION	ENGINEER