

PPAC series / PPAC-XX series

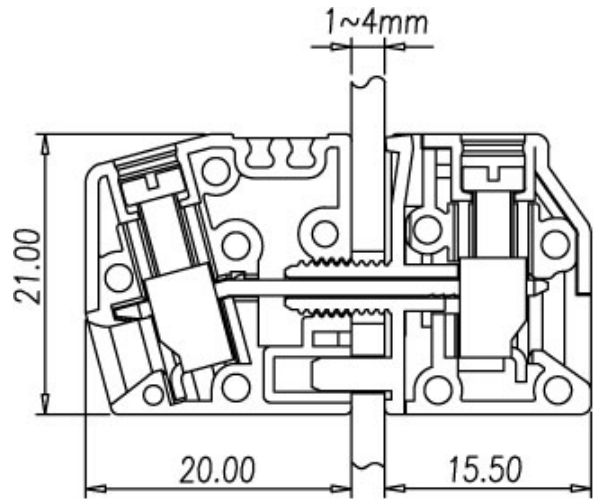

PPACN-4 / PPACN-4G



Approval	UL	
Technical Data	UL	IEC
Rated voltage	300V	400V
Rated current	30A	41A
Conductor cross-section, solid (AWG / mm ²)	30~10 / 0.2~6	
Conductor cross-section, flexible (AWG / mm ²)	30~10 / 0.2~4	
Rated impulse withstand voltage	6KV	
Torque (N-m)	0.59	
Screw	M3	
Wire strip length	9mm	
Insulating material	PA	
Outer dimension TxHxW (mm)	8.1 x 21 x 20	
Inner dimension TxHxW (mm)	8.1 x 21 x 15	

	Accessories	Cat. No.
Marking label		TM22
Tool		



Dimension

