

SPECIFICATION
 Current Rating:1A AC/DC
 Voltage Rating:50V AC/DC
 Withstanding Voltage:500V AC/Minute
 Contact Resistance:20 Milliohms Max.
 Insulation Resistance:500 Megaohms Min.
 Temperature Range:-25°C~+85°C
 RoHS Compliant

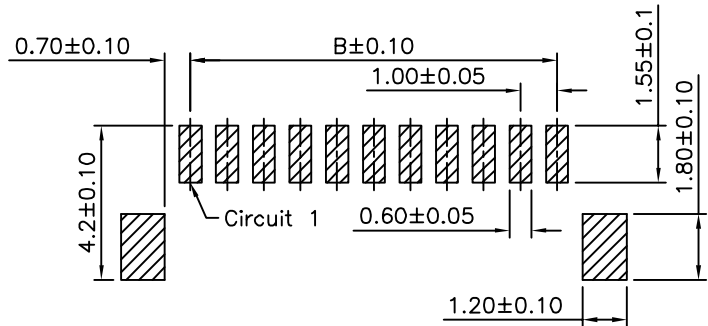

Recommended P.C.B. Layout(Top Side)
 P.C.B. Thickness=1.20~1.60mm(Tolerance:±0.05)

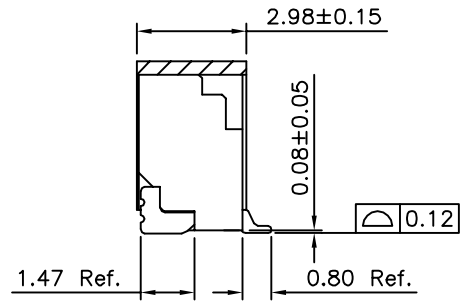
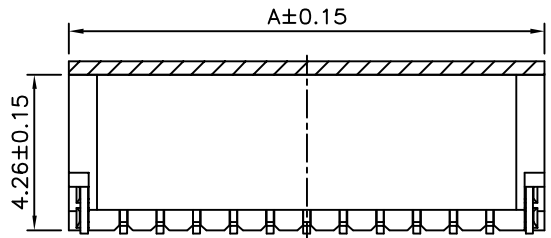
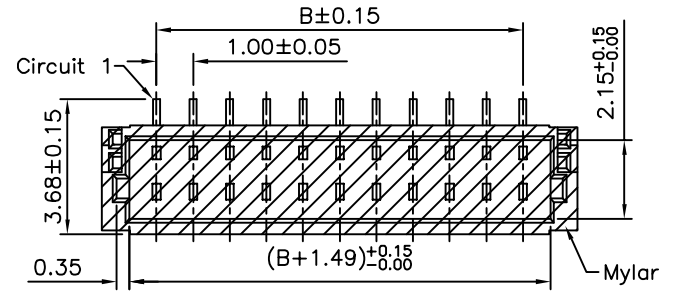

SH XX V C - R1K - H
 (1) (2) (3) (4) (5) (6)

- (1) SH:1.0 SH Series
- (2) XX: No. Of Position/Per Row
- (3) V:SMT Straight
- (4) C:With Mylar
- (5) R1K:Tape & Reel 1000 PCS/Reel
- (6) H:RoHS Compliant

Pin	A	B	Pin	A	B
2	4.00	1.00	12	14.00	11.00
3	5.00	2.00	13	15.00	12.00
4	6.00	3.00	14	16.00	13.00
5	7.00	4.00	15	17.00	14.00
6	8.00	5.00	16	18.00	15.00
7	9.00	6.00	17	19.00	16.00
8	10.00	7.00	18	20.00	17.00
9	11.00	8.00	19	21.00	18.00
10	12.00	9.00	20	22.00	19.00
11	13.00	10.00			

Name	Material	Remark
Fixed Slice	Brass	Matte Tin Over Nickel
Terminal	Brass	Matte Tin Over Nickel
Housing	PA9T,UL94V-0	Nature

AUK A MEMBER OF AUK GROUP
太聯事業股份有限公司
AUK CONTRACTORS CO., LTD.

CATEGORY		APPROVED BY		UNLESS OTHERWISE SPECIFIED TOLERANCES ARE .X ±0.25 .X' ±2* .XX ±0.20 .XX' ±1* .XXX ±0.10
PART No. SHXXVC-R1K-H		MEI		
DRAWING No. SHXXVC-R1K-H		CHECKED BY HZF		
		DRAWING BY WSS		
SCALE	NONE	REV.	BO	UNIT mm

NO.	REV.	REVISIONS	CHK	DATE

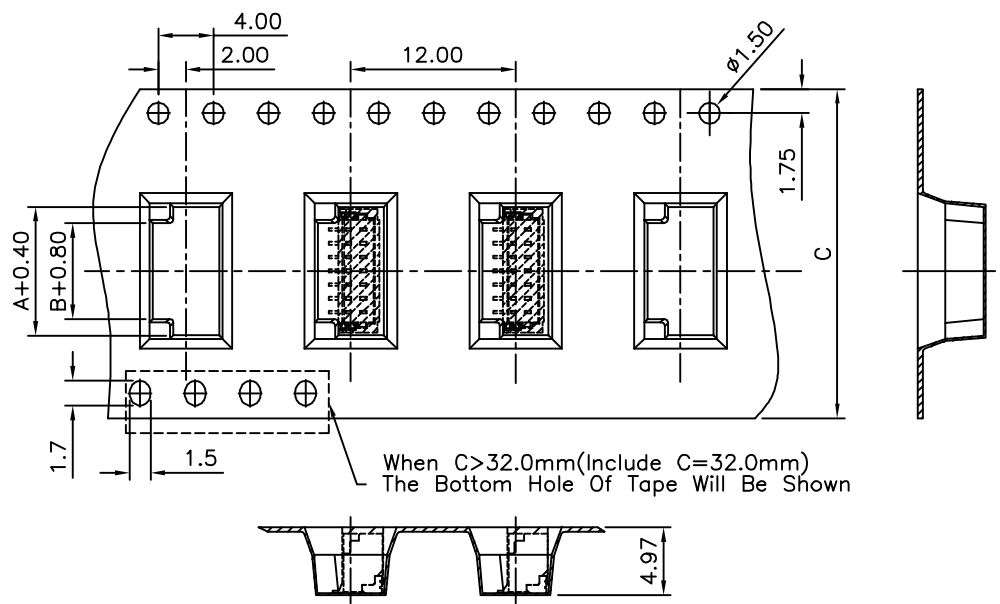
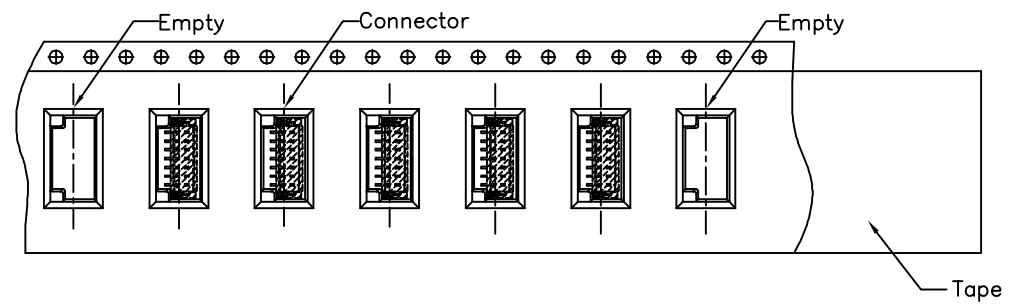
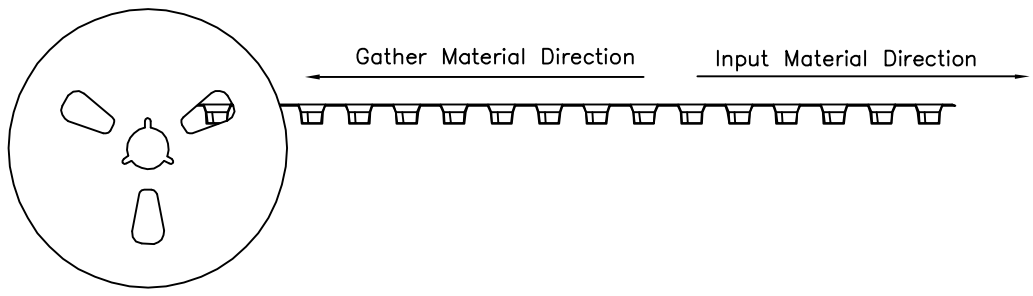

Pin	C	Reel/Box	PCS/Reel
2	16.0	16	1000
3			
4			
5			
*6			
7	24.0	12	
8			
*9			
*10			
*11			
*12	32.0	10	
*13			
*14			
*15			
*16			
*17	44.0	8	
*18			
*19			
*20			

The "*" Pin Of Tape & Reel Packaging Tooling Is Not Already

AUK A MEMBER OF AUK GROUP
太聯事業股份有限公司
AUK CONTRACTORS CO., LTD.

CATEGORY		APPROVED BY		UNLESS OTHERWISE SPECIFIED TOLERANCES ARE
PART No. SHXXVC-R1K-H		MEI		
DRAWING No. SHXXVC-R1K-H		CHECKED BY		.X ±0.25 .X* ±2*
SCALE NONE		DRAWING BY		.XX ±0.20 .XX* ±1*
REV.	BO	WSS		.XXX ±0.10
UNIT	mm	REV.		UNIT
NONE		BO		mm

NO.	REV.	BO	NEW RELEASE	HZF	05/02/2011
		REVISIONS		CHK	DATE