

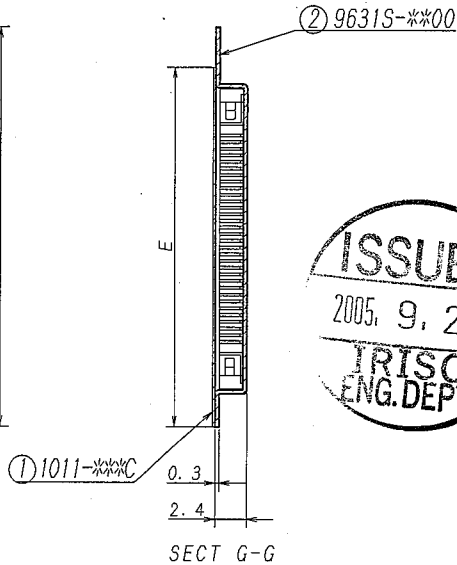

A B C D E F G H

PRODUCT WITHDRAWAL DIRECTION  
製品引き出し方向

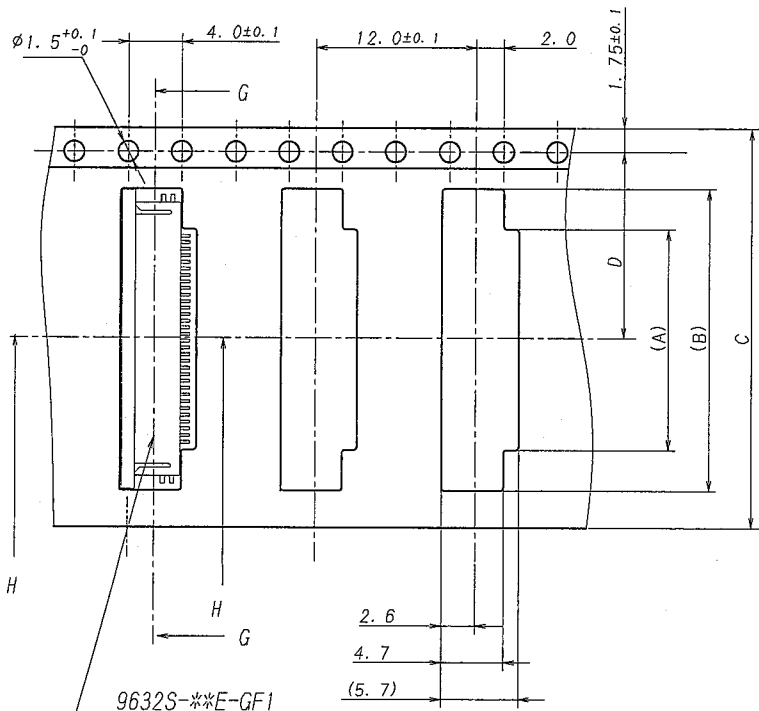

ISSUED  
2005. 9. 29  
IRISO  
ENG. DEPT.

枚数/CKT	製品番号/PARTS No	A	B	C	D	E	FDP No.
4	9632S-04Y910	2.6	8.9	16	7.5	13.5	06082504
5	-05Y910	3.1	9.4				06087520
6	-06Y910	3.6	9.9				06087670
7	-07Y910	4.1	10.4				06082507
8	-08Y910	4.6	10.9				06082508
9	-09Y910	5.1	11.4				
10	-10Y910	5.6	11.9				06082510
11	-11Y910	6.1	12.4				
12	-12Y910	6.6	12.9				
13	-13Y910	7.1	13.4	24	11.5	21.5	06082513
14	-14Y910	7.6	13.9				06082514
15	-15Y910	8.1	14.4				
16	-16Y910	8.6	14.9				06082516
17	-17Y910	9.1	15.4				
18	-18Y910	9.6	15.9				06082518
19	-19Y910	10.1	16.4				
20	9632S-20Y910	10.6	16.9				06082520

NOTE

1. 梱包数量/UNIT QUANTITY: 3000
2. リードテープ長さ/LEAD TAPE LENGTH

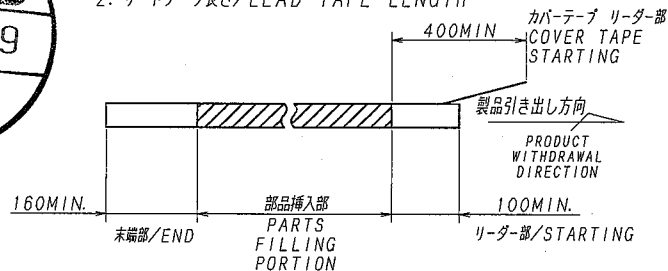

3. カバーテープの剥離強度/COVER TAPE PEELING FORCE  $\Delta: 0.2 \sim 1.3N$

SECT H-H

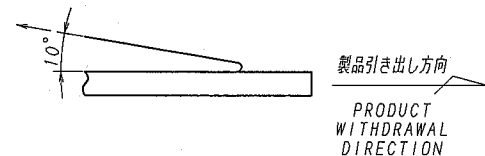
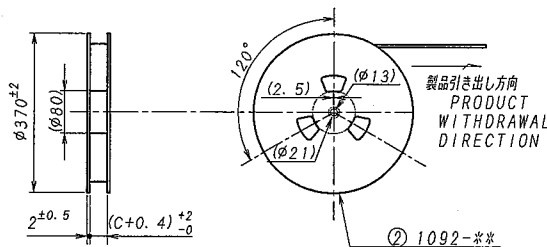

MATERIAL 材質					GENERAL TOLERANCES - 一般公差		SCALE 尺度		UNIT 単位		TITLE 名称	
① カバーテープ/COVER TAPE: PET-TYPE ② キャリアテープ/CARRIER TAPE: A-PET ③ リール/REEL: 紙/PAPER					DIM 寸法 ± 0.3 ANGLE 角度 ±		DR 1/25 Y. Ogura 3/27 CHK 1/05 Y. Yoshikai 9/27		mm		SERIES 9632 SOCKET TAPING PRODUCT 9632シリーズ ソケット エンボス梱包品	
FINISH 仕上り					3RD. ANG. PROJ. 三角法		IRISO ELECTRONICS CO., LTD. イリソ電子工業株式会社		APP 05/19/07		EDP No	
REVISION RECORD					DR		DATE		PARTS No 部番		上記参照/SEE THE CHART	
REVISED M.F. MS 05-9-29					44		65.9.27		9632S-**Y910		DWG No 図番	
RELEASED Y.O. 44 65.9.27									IMS-9632S-**Y910		REV. 9	

# 製品仕様書/Product Specification

No. IS-9632Z01 来歴 4

頁/Page 1/3

標題: 9632 シリーズ 0.5mmピッチ FPC/FFC コネクタ

制定年月日/ISSUED DATE '03-11-25

SUBJECT: Series 9632 0.5mm Pitch FPC/FFC Connector

改訂年月日/REVISED DATE '04-11-29

## 1. 適用範囲

本仕様書は、イリソ電子工業株式会社製 9632 シリーズ 0.5mmピッチ FPC/FFC コネクタに関する仕様及び性能上の必要事項について規定する。

## 1. Scope

This product specification is applied for IRISO ELECTRONICS CO., LTD. Series 9632 0.5mm Pitch FPC/FFC Connector.

## 2. 構造及び寸法

構造、寸法、主要部品の材質、表面処理等は添付図による。  
適合 FPC/FFC : 0.5mm ピッチ、厚さ 0.3±0.05mm  
適用製品 : IMSA-9632S-\*\*○-TB (○=A~F TYPE)  
IMSA-9632S-\*\*○-GF1 (○=A~F TYPE)

## 2. Configuration, dimensions and materials

See the product drawing attached.  
FPC/FFC Mated : 0.5mm Pitch, t=0.3±0.05mm  
Applied to product : IMSA-9632S-\*\*○-TB (○=A~F TYPE)  
IMSA-9632S-\*\*○-GF1 (○=A~F TYPE)

## 3. 定格

- (1)最大定格電圧 50V (AC, DC)
- (2)最大定格電流 0.5A
- (3)使用温度範囲 -40~+105℃

## 3. Rating

- (1) Maximum rating voltage: 50V (AC, DC)
- (2) Maximum rating current: 0.5 A
- (3) Temperature range : -40~+105℃

## 4. 試験環境

特に規定のある場合を除き、性能試験は、下記の試験条件のもとで行う。

- 常温 15~35℃
- 常湿 25~85%RH (相対湿度)

## 4. Performances

All performance test, unless otherwise specified, is taken as per following environmental conditions.

- Ambient temperature : 15~35℃
- Ambient temperature : 25~85%RH

## 5. 性能

### 5-1. 電気的性能

## 5. Performance

### 5-1. Electrical performance

項目/Item	条件/Test condition	規格/Specification
1 接触抵抗 Contact Resistance	短絡電流 1mA、最大開放電圧 20mV、周波数 1kHz のローレベル抵抗計にて測定する。 It shall be measured by the dry electric circuit specified as follows; 1mA, 20mV, 1kHz frequency.	初期値 : 30mΩ以下 各試験後 : 50mΩ以下 Initial : 30mΩ or below. After each test : 50mΩ or below.
2 耐電圧 Dielectric Withstanding Voltage	隣接する極間に AC250V を 1分間印加する。 AC 250V shall be applied for one minute to between next terminals.	絶縁破壊等異常のない事。 Should not have any changes.
3 絶縁抵抗 Insulation resistance	隣接する極間に DC250V を印加する。 DC250V shall be applied to between next terminals.	初期値 : 100MΩ以上 耐湿試験後 : 100MΩ以上 Initial : 100MΩ or more After humidity test: 100MΩ or more
4 外観 Appearance	目視 Visual	有害となる割れ、剥がれ、ガタ変形、変色のない事。 Should not have any flaw, scratch, discoloration, and crushed.

### 5-2. 機械的特性

### 5-2. Functional Performance

項目/Item	条件/Test condition	規格/Specification
1 端子の保持力 Contact retention force	端子に 25mm/分の速度で加重を加え、端子がハウジングより抜け始めたときの荷重を測定する。 The contact shall be pulled at the speed of 25mm per minute and measured the force when the contact begins to remove from the housing.	2.45N 以上 2.45N or more
2 挿抜耐久性 Insertion /Extraction endurance	FPC/FFC を 20 回繰返し挿抜を行ない接触抵抗を測定する。 (スライダーを開閉し、開時毎に挿抜する。) The FPC/FFC shall be mated and unmated 20 times and measured the contact resistance.	50mΩ以下 50mΩ or below
3 衝撃試験 Shock test	FPC/FFC を嵌合した状態にて治具に取り付け、加速度 980m/s <sup>2</sup> 、衝撃作用時間 6ms を X,Y,Z、方向の 6 面に各 10 回加え、試験中の瞬断の有無の確認、試験後の接触抵抗の測定及び外観観察する。 The connector and FPC/FFC mated are installed in the machine. They are applied pulses 10 times to each 6 faces of 3 mutually perpendicular directions(X,Y,Z); in conditions as specified ; acceleration of 980m/s <sup>2</sup> and shock pulses for a duration of 6ms . It shall be tested the discontinuity of the contact current during the test and measured the contact resistance and observed its appearance after the test	試験中 1 μs 以上の瞬断の無き事。 50mΩ以下 外観 : 異常なきこと Discontinuity : 1 μs or less. 50mΩ or below Should not have any damages

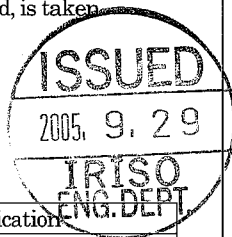

4	振動試験 Vibration test	FPC/FFC を嵌合した状態にて、振動周波数 10~500~10Hz、掃引時間 1 2分、振幅 1.5mm、又は加速度 98m/s <sup>2</sup> のいずれか小さい方にて X 軸方向に 4 時間、Y Z 軸方向に各 2 時間計 8 時間の振動を加える。試験中、瞬断の有無の確認、試験後の接触抵抗の測定及び外観観察をする。 The connector and FPC/FFC mated is vibrated in the frequency range of 10~500~10Hz/12min and in the constant vibration amplitude 1.5mm or the acceleration of 98m/s <sup>2</sup> . The amplitude or the acceleration above shall be chosen either one under which the connectors is loaded more slightly. And this motion is applied for period of 4hours in one of 3 mutually perpendicular directions(X-axis), and 2hours in other two of them(Y and Z-axis). It shall be tested the discontinuity of the contact current during the test and measured the contact resistance and observed its appearance after the test.	試験中 1 μs 以上の瞬断の無き事。 50mΩ以下 外観：異常なきこと  Discontinuity: 1 μs or less. 50mΩ or below Should not have any damages
5	FPC/FFC 保持力 FPC/FFC retention force	FPC/FFC に 25mm/分の速度で加重を加え、ハウジングより抜け始めたときの荷重を測定する。 The FPC/FFC shall be pulled at the speed of 25mm per minute and measured the force when the FPC/FFC begins to remove from the housing.	0.29N/極 以上  0.29N/PIN or more

5-3. 環境特性

5-3.Environmental performance

項目/Item	条件/Test condition	規格/Specification
1 耐熱性 Heat resistance	FPC/FFC を嵌合した状態にて温度 105±2℃の恒温槽に 96 時間放置し、試験後接触抵抗測定及び外観観察を行う。 The connector and FPC/FFC mated is exposed in the heat chamber 105±2℃ for 96 hours. It shall be measured the contact resistance and observed its appearance after the test.	50mΩ以下 外観：異常なきこと 50mΩ or below Should not have any damages
2 耐寒性 Chilly resistance	FPC/FFC を嵌合した状態にて温度-40±2℃の低温槽に 96 時間放置し、試験後接触抵抗測定及び外観観察を行う。 The connector and FPC/FFC mated is exposed in the chilly chamber-40±2℃ for 96 hours. It shall be measured the contact resistance and observed its appearance after the test.	50mΩ以下 外観：異常なきこと 50mΩ or below Should not have any damages
3 耐湿性 Humidity	FPC/FFC を嵌合した状態にて温度 60±2℃、相対湿度 95%RH の恒温恒湿槽に 96 時間放置し、試験後接触抵抗測定及び外観観察を行う。 The connector and FPC/FFC mated is exposed in the heat chamber 60±2℃,95%RH for 96 hours. It shall be measured the contact resistance and observed its appearance after the test.	50mΩ以下 外観：異常なきこと 50mΩ or below Should not have any damages
4 H <sub>2</sub> S ガス試験 H <sub>2</sub> S gas test	FPC/FFC を嵌合した状態にて、温度 40±2℃相対湿度 75%RH、濃度 3±1ppm の雰囲気中に 96 時間放置し、試験後接触抵抗を測定する。 The connector and FPC/FFC mated is exposed in the H <sub>2</sub> S gas chamber 40±2℃,75%RH 3±1ppm for 96 hours. It shall be measured the contact resistance after the test.	50mΩ以下 外観：異常なきこと 50mΩ or below Should not have any damages
5 SO <sub>2</sub> ガス試験 SO <sub>2</sub> gas test	FPC/FFC を嵌合した状態にて、温度 40±2℃相対湿度 75%RH、濃度 10±3ppm の雰囲気中に 96 時間放置し、試験後接触抵抗を測定する。 The connector and FPC/FFC mated is exposed in the SO <sub>2</sub> gas chamber 40±2℃,75%RH 10±3ppm for 96 hours. It shall be measured the contact resistance after the test.	50mΩ以下 外観：異常なきこと 50mΩ or below Should not have any damages
6 塩水噴霧試験 Salt spray test	FPC/FFC を嵌合した状態にて、温度 35±2℃、濃度 5±1%、の塩水噴霧中に 48 時間放置し、試験後接触抵抗を測定する。 The connector and FPC/FFC mated is exposed in the salt spray chamber 35±2℃,5±1% salt density for 48 hours. It shall be measured the contact resistance after the test.	50mΩ以下 外観：異常なきこと 50mΩ or below Should not have any damages
7 冷熱衝撃試験 Thermal shock test	FPC/FFC を嵌合した状態にて下図の温度条件を 1 サイクルとして 10 サイクル実施し、試験後接触抵抗測定及び外観観察を行う。 The connector and FPC/FFC mated is exposed 10 cycles in the following temperature conditions. It shall be measured the contact resistance and observed its appearance after the test.	50mΩ以下 外観：異常なきこと 50mΩ or below Should not have any damages

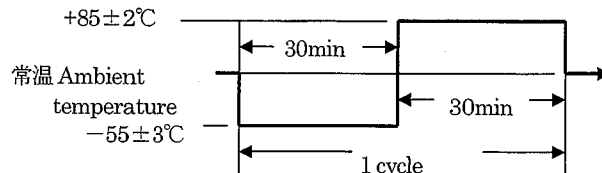

項目/Item	条件/Test condition	規格/Specification
8 温湿度 サイクル試験 Humidity resistance	<p>FPC/FFC を嵌合した状態にて下図の温度条件を 1 サイクルとして 10 サイクル実施し、試験後接触抵抗測定及び外觀観察を行う。 The connector and FPC/FFC mated is exposed 10 cycles in the following temperature conditions. It shall be measured the contact resistance and observed its appearance after the test.</p> <p>+80±2°C 95%RH</p> <p>-20±3°C</p> <p>← 2h → ← 2h → ← 2h → ← 2h →</p> <p>← 1 cycle →</p>	<p>50mΩ以下 外觀：異常なきこと 50mΩ or below Should not have any damages</p>

5-4. その他の性能

5-4.Other specification

項目/Item	条件/Test condition	規格/Specification
1 半田付け性 Solder ability	<p>コネクタの半田付け部をフラックスに浸漬した後、245±5°Cの Sn-Ag-Cu 系の鉛フリー半田槽に 3±0.5 秒浸す。 The terminal of connector shall be put into the flux and dipped into Pb free solder bath(Type of Sn-Ag-Cu) 245±5°C, 3±0.5s.</p>	<p>浸した面積の 95%以上に半田が、むらなく付着する事。 Solder shall be covered 95% or more of the area that is Dipped into the solder bath</p>
2 半田耐熱性 Soldering heat test	<p>下記条件にて、半田耐熱試験を行う。 The connector shall be tested resistance to soldering heat in the following conditions. (1)リフローの場合 / In case of reflow リフロー回数 / number of reflow : 1 回 / Once 250°C(ピーク温度), MAX10s (Peak temperature)</p> <p>← (90±30s) →</p> <p>(予熱 150~180°C) (pre-heat : from 150~180°C)</p> <p>250°C</p> <p>230°C MIN.</p> <p>(30~60s)</p> <p>温度は製品上面の温度とする。 The temperature shall be measured on the surface of the Product.</p>	<p>実使用上の問題無き事 Should not have any problems.</p>
3 温度上昇試験 Raise of temperature test	<p>最大許容電流を通電し、熱伝対法にてコネクタの温度上昇を測定する。 The connector shall be operated in the maximum raise of current and measured raise of the temperature at contact point.</p>	<p>温度上昇：30°C以下 Raise of temperature: 30°C or below</p>

1. 適用範囲

本仕様書は、イリソ電子工業株式会社製コネクタに関する梱包仕様について規定する。

1. Scope

This product specification are applied for IRISO ELECTRONICS CO., LTD. CONNECTOR.

2. 梱包方法

本製品は、専用のエンボステープに梱包しダンボール箱に梱包する。(梱包数量はエンボス図面参照)

2. Method of Packing.

This product shall be packed in the emboss taping and then packed in cardboard box.  
(Packing quantity shall be seen to emboss taping drawing)

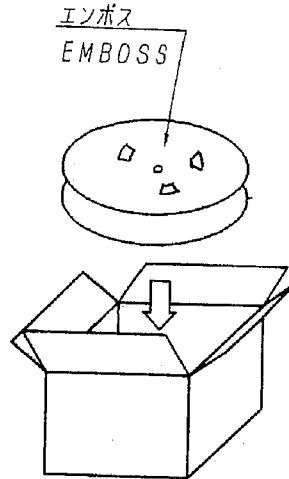

箱の大きさ / BOX SIZE  
385×385×320  
385×385×140

3. 現品票

エンボス梱包が完了したリールの表面に現品票を貼ります。尚、これには品名、部番、数量と製造番号が記入されています。

3. Product label

A product label shall be put on an emboss reel completed.  
It is filled with the product name, parts number quantity and lot number.

現品票	
納入先	御中
品名	
部品番号	
数量	個
製造番号	
IRISO 電子工業株式会社	

CUSTOMER	
ITEM	
DRAWING No.	
QUANTITY	PCS.
LOT No.	

製造番号の読み方 / how to read the product level

7 4 04 00011

製造番号 / Product No.

処理日(移動伝票を発行した日) / Product day

処理月(移動伝票を発行した月) / Product month

1~9月 / Jan~Sep : 1~9, 10月 / Oct X

11月 / Nov : Y, 12月 / Dec : Z

西暦下1桁(移動伝票を発行した年) / Product year