

Industrial Nano USB

USB Series

Customer: _____

Customer

Part Number: _____

InnoDisk

Part Number: _____

InnoDisk

Model Name: _____

Date: _____

InnoDisk Approver	Customer Approver

the total solution for
industrial flash storage

Table of contents

REVISION HISTORY	3
1. Introduction.....	6
2. Features.....	6
3. Pin Assignment.....	8
4. Specifications	8
4.1 CE and FCC Compatibility	8
4.2 RoHS Compliance	8
5. Environmental Specifications	9
5.1 Temperature Ranges.....	9
5.2 Humidity.....	9
5.3 Shock and Vibration.....	9
5.4 Mean Time between Failures (MTBF)	9
5.5 Mechanical Dimensions.....	10
5.6 Electrical Specifications	10
5.6.1 Absolute Maximum Ratings	10
5.6.2 Operating Conditions.....	10
6. i-S.M.A.R.T Utility	11
7. Part Number Rule.....	13

REVISION HISTORY

Revision	Description	Date
Preliminary	First Release	2012/11/14

List of Tables

Table 1: Industrial Nano USB Pin Assignments	8
Table 2: Shock/Vibration Testing for Industrial Nano USB.....	9
Table 3: Industrial Nano USB MTBF	9
Table 4: Industrial Nano USB	10
Table 5: Industrial Nano USB Operating Conditions.....	10

List of Figures

Figure 1: Appearance of Industrial Nano USB	6
Figure 2: Mechanical Dimension of Industrial Nano USB	10
Figure 3: User Interface of i-S.M.A.R.T Utility	11

1. Introduction

The InnoDisk Industrial Nano USB is the smallest industrial USB storage in the world. It electrically complies with High-speed USB 2.0 interface & backward compatible with USB 1.1. In order to fulfill the industrial applications, Industrial Nano USB is embedded with SLC NAND flash. Moreover, it features enhanced power cycling which ensures data integrity in flash when abnormal power failure happens.

The Industrial Nano USB offers following key features which make it more reliable, such as being ESD resistant to 8KV (contact discharge) and 15KV (air discharge). At the same time, it also features a wide operating temperature range from -40°C to 85°C, making it well-suited for industrial control applications in a variety of different rugged operating conditions. Also, the health of Industrial Nano USB can be monitored by a specific i-S.M.A.R.T utility.



Figure 1: Appearance of Industrial Nano USB

2. Features

The Industrial Nano USB provides following features:

- NAND flash type: SLC
- Capacities: 1GB, 2GB, 4GB, 8GB
- High-speed USB 2.0 interface; backward compatible with USB 1.1
- BCH ECC: 16bits/1KBytes
- High performance (Sequential Read/Write, Max, MB/sec):
 - 4GB/8GB: 19/17
 - 2GB: 18/15

- 1GB:18/13
- Customized PID/VID (specify 4bits for each ID, Hexadecimal(0~F))
 Ex: PID: 182C; VID: 019F
- Global Wear-leveling supported
- Power supply: 5V DC \pm 5%
- Low power consumption (Max.):
 - Read: 90mA
 - Write: 90mA
 - Idle: 60mA
- ESD Proof:
 - Air Discharge: 15KV
 - Contact Discharge: 8KV
- Temperature range:
 - Operating:
 - 0°C ~ +70°C (Standard grade)
 - 40°C ~ +80°C (Industrial grade)
 - Storage: -55°C ~ +95°C
- Humidity: 10-95%, non-condensing
- Environmental reliability:
 - Vibration: 7 Hz to 2K Hz, 5G, 3 axes
 - Shock: Duration: 0.5ms, 50G, 3 axes
- Dimension (W x L x H): 15.4 x 19.4 x 6.9 (\pm 0.2mm)
- Certification: CE, FCC, RoHS
- Weight: 2.6g

3. Pin Assignment

Please refer to Table 1 for Industrial Nano USB pin assignments.

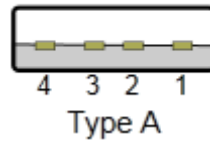

Pin No.	Name	Description
1	VBUS	+5V
2	D-	Data -
3	D+	Data +
4	GND	Ground

Table 1: Industrial Nano USB Pin Assignments

4. Specifications

4.1 CE and FCC Compatibility

The InnoDisk Industrial Nano USB conforms to CE requirements and FCC standards.

4.2 RoHS Compliance

The InnoDisk Industrial Nano USB is fully compliant with RoHS directive.

5. Environmental Specifications

5.1 Temperature Ranges

- Operating Temperature Range:
 - ◆ 0°C ~ +70°C (Standard grade)
 - ◆ -40°C ~ +85°C (Industrial grade)
- Storage Temperature Range: -55°C to +95°C

5.2 Humidity

Relative Humidity: 10-95%, non-condensing.

5.3 Shock and Vibration

Table 2: Shock/Vibration Testing for Industrial Nano USB

Reliability	Test Conditions	Reference Standards
Vibration	7 Hz to 2000 Hz, 5G, 3 axes	IEC 68-2-6
Shock	Duration: 0.5ms, 50G, 3 axes	IEC 68-2-27

5.4 Mean Time between Failures (MTBF)

Table 3 summarizes the MTBF prediction results for various Industrial Nano USB configurations. The analysis was performed using a RAM Commander™ failure rate prediction.

- **Failure Rate:** The total number of failures within an item population, divided by the total number of life units expended by that population, during a particular measurement interval under stated condition.
- **Mean Time between Failures (MTBF):** A basic measure of reliability for repairable items: The mean number of life units during which all parts of the item perform within their specified limits, during a particular measurement interval under stated conditions.

Table 3: Industrial Nano USB MTBF

Product	Condition	MTBF (Hours)
Industrial Nano USB	Telcordia SR-332 GB, 25°C	3,000,000

5.5 Mechanical Dimensions

- Dimension (W x L x H): 15.4 x 19.4 x 6.9 (±0.2mm)

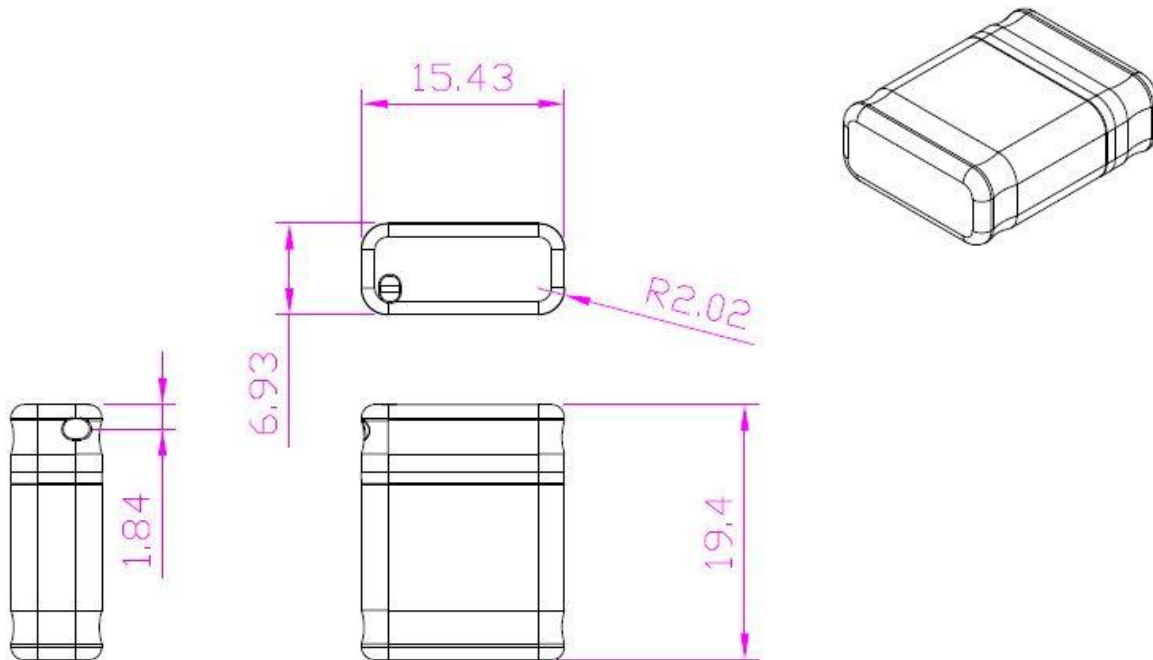

Figure 2: Mechanical Dimension of Industrial Nano USB

5.6 Electrical Specifications

5.6.1 Absolute Maximum Ratings

Table 4: Industrial Nano USB

Item	Symbol	Rating	Unit
Storage Temperature	T _{Storage}	-55 ~ +95	°C
Ambient Operating Temperature	T _a	0 ~ +70	°C
3.3V supply voltage	VCC33	-0.3 ~ 3.6	V
1.8V supply voltage	VCC18	-0.3 ~ 2	V
3.3V buffer input voltage	V _{in33}	-0.3 ~ 3.6	V
3.3V/5V buffer input voltage	V _{in335}	-0.3 ~ 5	V
1.8V buffer input voltage	V _{in18}	-0.3 ~ 2	V

5.6.2 Operating Conditions

Table 5: Industrial Nano USB Operating Conditions

Item	Symbol	Rating	Unit
USB 5V supply voltage	USBV _{in}	3.2 ~ 5.5	V
3.3V supply voltage	VDD33	3.0 ~ 3.6	V

1.8V supply voltage	VDD18	1.6 ~ 2	V
---------------------	-------	---------	---

6. i-S.M.A.R.T Utility

The health of Industrial Nano USB can be monitored by a specific i-S.M.A.R.T utility as below:

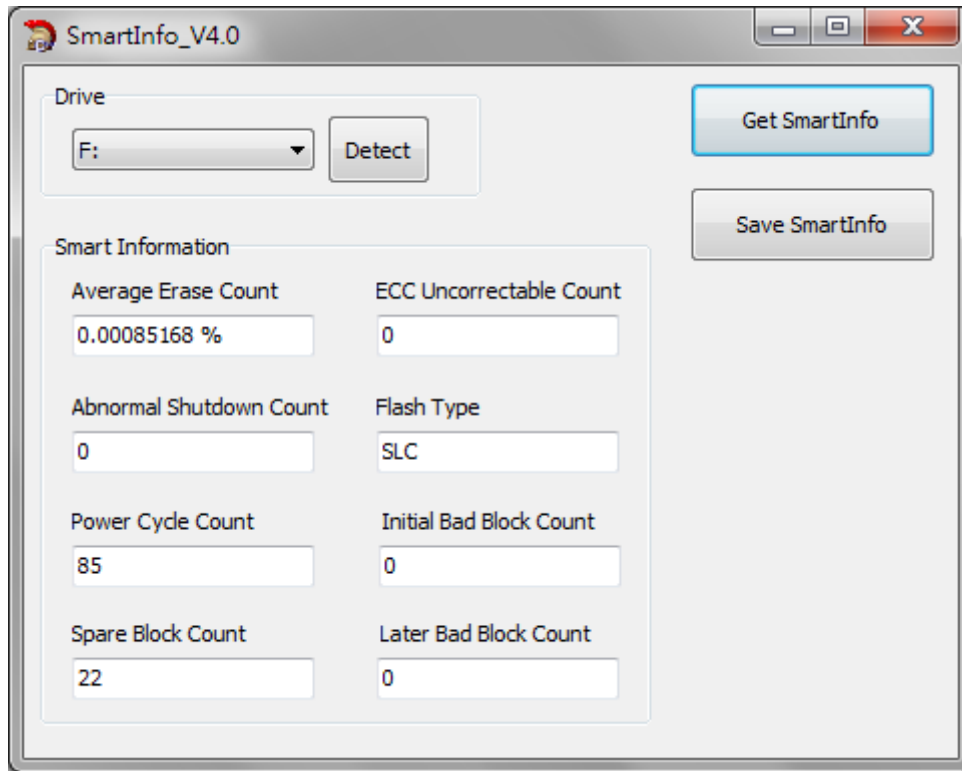

Figure 3: User Interface of i-S.M.A.R.T Utility

Detailed Description for SMART Information:

- **Average Erase Count**

Value: To record average erase ratio. This value is calculated by “total erase counts”, “Flash P/E cycles”, “Flash total blocks”.

Initial value = 00.00%

Maximum value = 100.00%

- **Abnormal Shutdown Count**

Value: To record abnormal shutdown condition. Increasing this value by 1 when detected error in the power on stage.

Initial value = 0.

Maximum value = 4294967295.

- **Power Cycle Count**

Value: To record power cycle condition. Increasing this value by 1 when a power Cycle (both normal and abnormal) occurred.

Initial value = 0.

Maximum value = 4294967295.

- **Spare Block Count**

Value: To record spare block counts. Decreasing this variable when detected run-time bad blocks. (note: run-time bad blocks may be “erase error”, “program error”, “read error”.)

Initial value = depends on Flash.

Maximum value = 255.

Minimum value = 0.

- **ECC Uncorrectable Count**

Value: To record ECC uncorrectable block counts. Increase this value by 1 when fatal error occurred in Flash read operation.

Initial value = 0.

Maximum value = 255.

- **Flash Type**

Value: To determinate mounted Flash type, and always keep in original value.
0: SLC, 1: MLC.

Initial value = depends on Flash.

- **Initial Bad Block Count**

Value: To record initial bad blocks when MP process, and always keep in original value.

Initial value = depends on Flash.

Maximum value = 65535.

- **Later Bad Block Count**

Value: To record run time bad blocks. Increasing this variable when detected run-time bad blocks.

Initial value = 0.

Maximum value = 65535.

7. Part Number Rule

Part Number	1	2	3	4	5	6	7	8	9	10	11	12	13	14	15	16	17	18	19	20
	D	E	U	N	-	0	8	G	S	2	3	A	W	1	S	B	-			
																T				
Description	Disk	Industrial Nano USB			-	Capacity			Category		Internal control	Operation Temp.	PCB Version	Channel	Flash		Customized Code			
Definition																				
Code 1st (Disk)											Code 12th (Internal control)									
D: Disk											Code 13th (Operation Temperature)									
Code 2nd ~ 4th (Form Factor)											C: Standard Grade (0°C ~ +70°C)									
EUN: Industrial Nano USB											W: Industrial Grade (-40°C ~ +85°C)									
Code 6th ~8th (Capacity)											Code 14th (PCB Version)									
01G: 1GB											1: First Version									
02G: 2GB											Code 15th (Channel)									
04G: 4GB											S: Single									
08G: 8GB											Code 16th (Flash)									
Code 9th ~11th (Category)											B: Toshiba SLC (1GB)									
S23: Industrial Nano USB											T: Micron SLC (2/4/8GB)									