

Mechanical:

REV.	ECN NO.	DESCRIPTION	DATE	APPD
A	REL		07/12/2009	

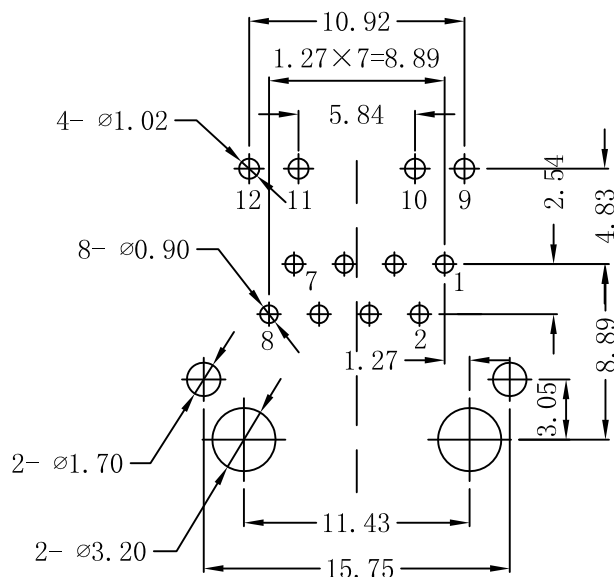
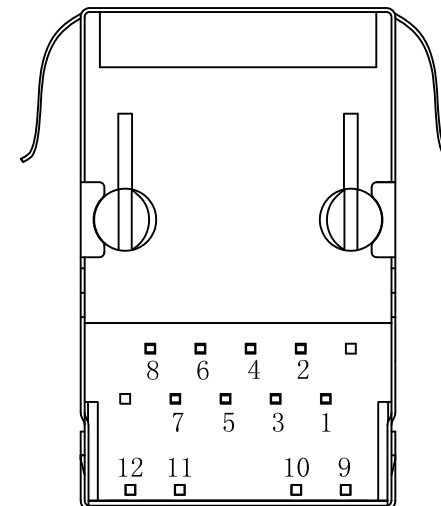
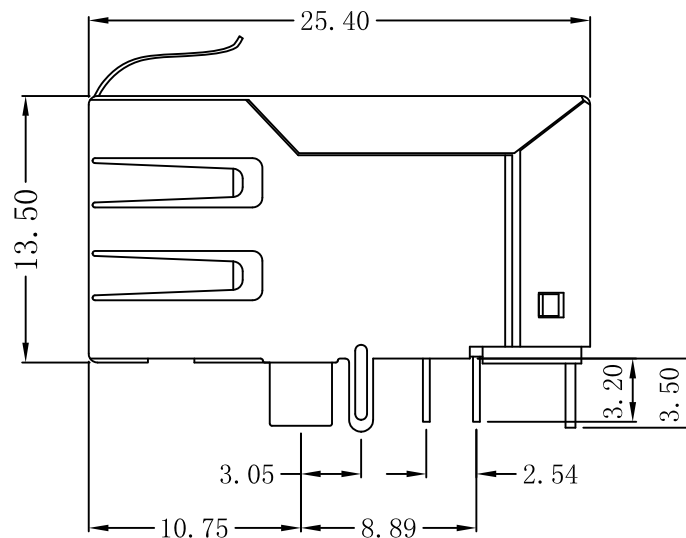
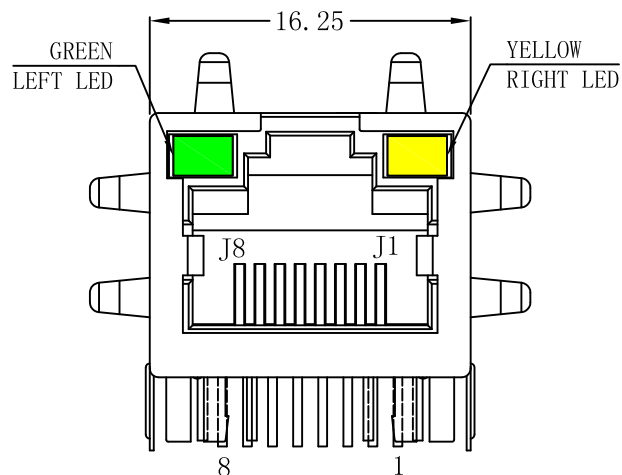

SUGGESTED PCB LAYOUT(TOP VIEW)

NOTES:

1. Designed to support application, such as SOHO (ADSL modems), LAN-on-Motherboard (LOM), hub and Switches.
2. Meets IEEE 802.3 specification
3. Connector Materials:
Housing: Thermoplastic UL94V-0
Contact/Shield: Copper alloy
Shield plating: Nickel
Contact plating: Gold 6 micro-inches min. In contact area.
4. Wave solder tip temperature: 265°C Max
Wave solder tip temperature time: 5 Sec Max
5. UL Certification: File Number E321120



X:X	± 0.20	APPD:	Trxcom
X:XX	± 0.10	CHKD:	
X:XXX	± 0.05	DR: C. H. Y	TITLE: RJ45 Connector With 10/100 Base-TX Integrated Magnetic
ANGLES	$\pm 1^\circ$	UNIT: mm	PART NO.: TRJ6014AHNL
	SCALE: 2/1	SHEET: 1/2	REV: A
			DWG NO.: TRC09120701

Schematic:

REV.	ECN NO.	DESCRIPTION	DATE	APPD
A	REL		07/12/2009	

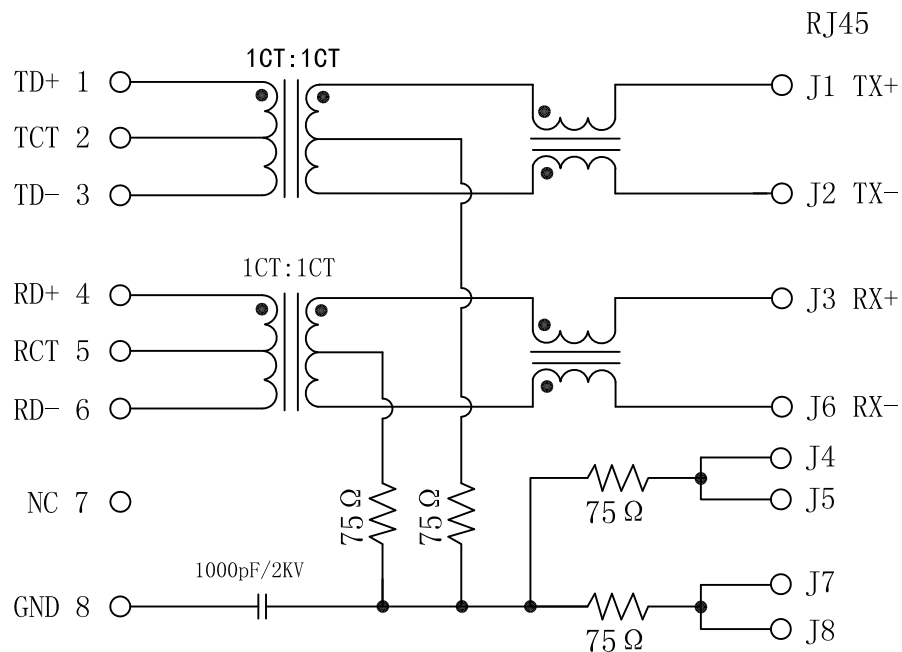

Electrical Specification @25°C

- Turns Ratio:
TX=1CT:1CT RX=1CT:1CT
- OCL: 350uH Min
@100KHz/100mVRMS 8mA DC BIAS
- Return Loss:
1-30MHz:-18dB Min
30-60MHz:-[18+20LOG(F/30MHz)]dB Min
60-80MHz:-12dB Min
- Crosstalk:
500KHz-100MHz:-30dB Min
- Insertion Loss:
1-100MHz:-1.1dB Max
- CMR:
100KHz-100MHz:-30dB Min
- DCMR:
100KHz-100MHz:-40dB Min
- Isolation Voltage: 1500Vrms
- Operating Temperature: -40°C ~ +85°C.

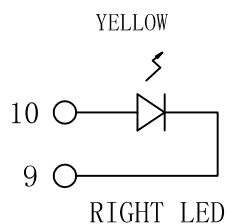
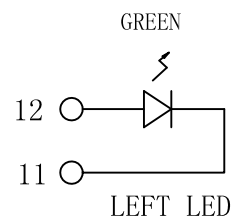

X:X	±0.20	APPD:	Trxcom ShenZhen Trxcom Electronics Co., ltd
X:XX	±0.10	CHKD:	
X:XXX	±0.05	DR: C. H. Y	TITLE: RJ45 Connector With 10/100 Base-TX Integrated Magnetic
ANGLES	±1°	UNIT: mm	PART NO.: TRJ6014AHNL
	SCALE: 2/1	SHEET: 2/2	REV: A DWG NO.: TRC09120701

TRXCOM

Part NO: TRJ6014AHNL

PART NAME: Lan filter in DIP connector



REV: A

TEMP (°C): 25

HUM (%): 65 RH

SUGGESTED PROFILE OF WAVE SOLDER FOR ROHS PRODUCT

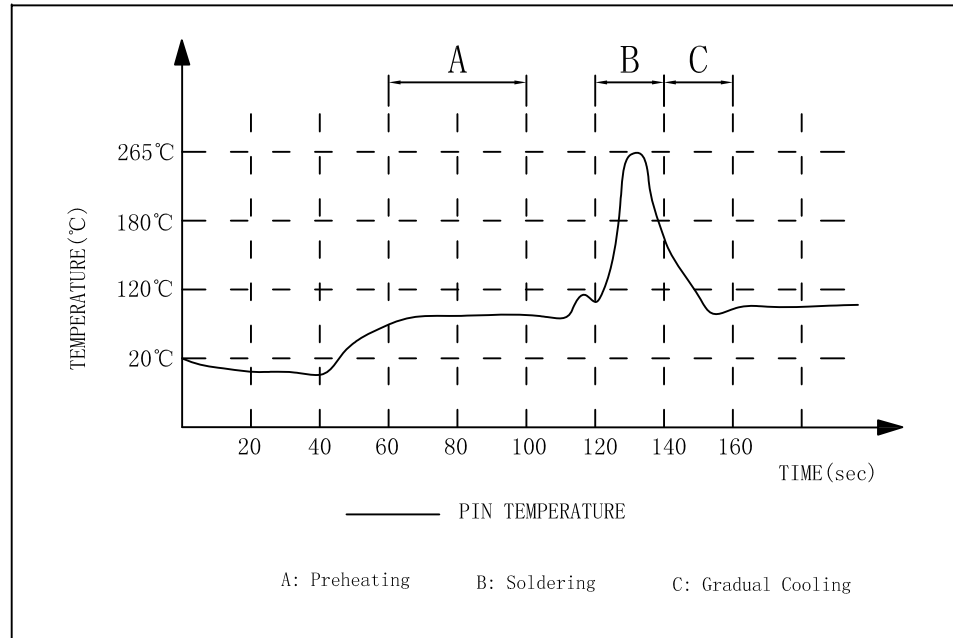

(1) Tip Temperature: 265°C max

(2) Tip Temperature time: 5sec max

Note: The melting point of Tin: 219°C

TRXCOM

PACKAGING

Part number: TRJ6014AHNL

1. Packaging unit: 60PCS/tray

2. Packaging material: PVC

3. Packaging shape: [Unit=cm]

4. Outer carton

Unit: 20Trays with plastic bag / outer carton (1200PCS) (G.W.: 11Kg)

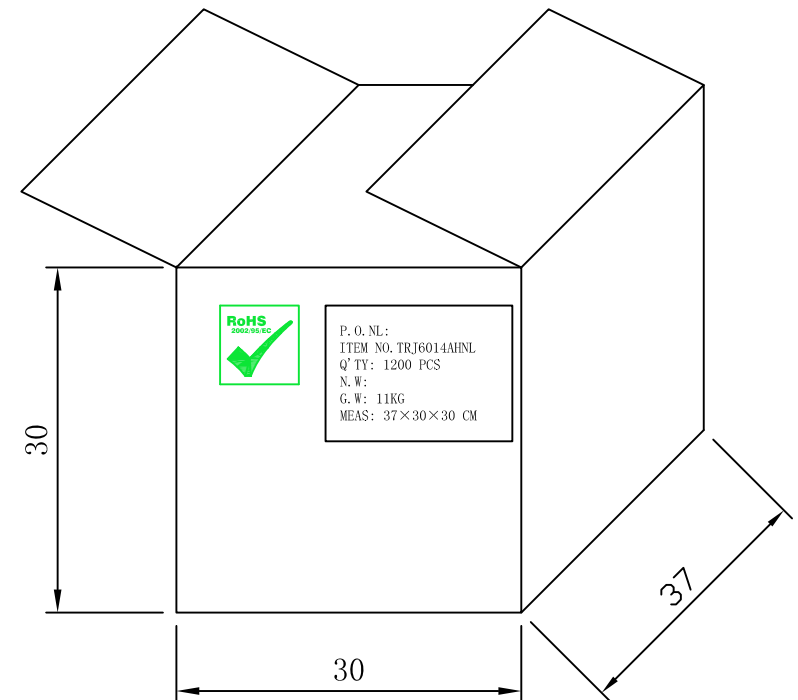
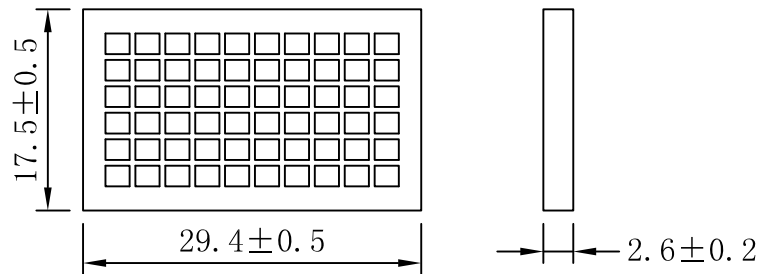

ORDER INFORMATION:
MOQ 4800PCS IN FOUR CTNS