

Mechanical:

REV.	ECN NO.	DESCRIPTION	DATE	APPD
A	REL		2009/08/31	

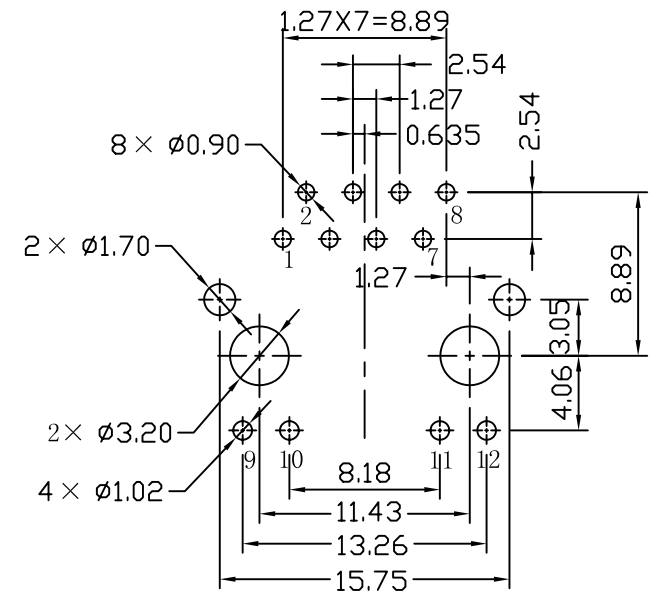

SUGGESTED PCB LAYOUT (TOP VIEW)

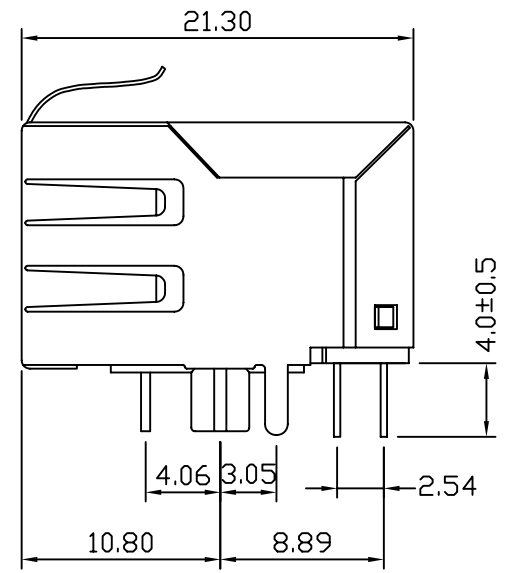
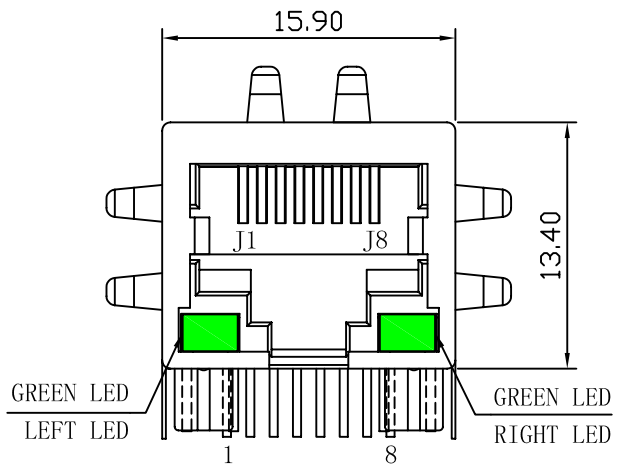
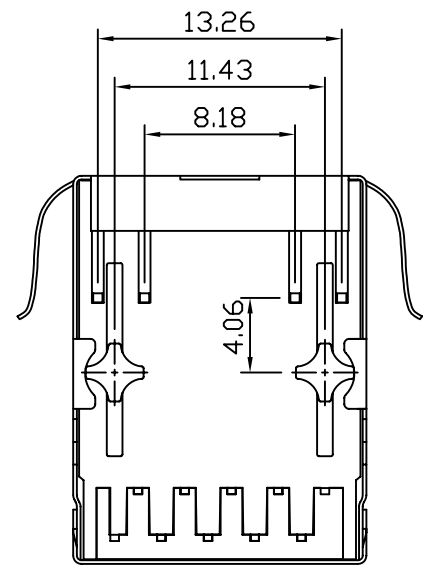

NOTES:

1. Designed to support application, such as SOHO (ADSL modems), LAN-on-Motherboard (LOM), hub and Switches.
2. Meets IEEE 802.3 specification
3. Connector Materials:
 Housing: Thermoplastic UL94V-0
 Contact/Shield: Copper alloy
 Shield plating: Nickel
 Contact plating: Gold 6 micro-inches min. In contact area.
4. Wave solder tip temperature: 265°C Max
 Wave solder tip temperature time: 5 Sec Max.
5. UL Certification: File Number E321120



X:X ±0.25	APPD:	Trxcom		
X:XX ±0.20	CHKD:	ShenZhen Trxcom Electronics Co., Ltd		
X:XXX ±0.05	DR: C. H. Y	TITLE: RJ45 Connector with 10/100 Base-T Integrated Magnetics		
ANGLES ±1°	UNIT: mm	PART NO.: TRJ4012GFNL		
	SCALE: 2/1	SHEET: 1/2	REV: A	DWG NO.: TRC09083101

Schematic:

REV.	ECN NO.	DESCRIPTION	DATE	APPD
A	REL		2009/08/31	

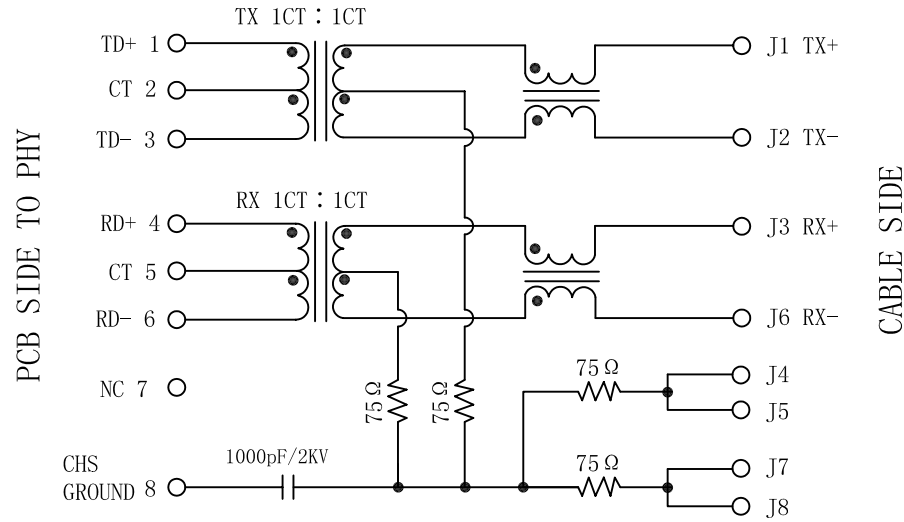

ELECTRICAL SPECIFICATIONS @25°C

- Turn Ratio ($\pm 2\%$):
TX=1CT:1CT RX=1CT:1CT
- Inductance OCL: 350uH MIN
@ 100KHz/0.1V 8mA DC Bias
- Insertion Loss:
-1.0dB MAX @ 1.0-100MHz
- Return Loss:
-18dB MIN @ 1-30MHz
-15dB MIN @ 30-60MHz
-12dB MIN @ 60-80MHz
-10dB MIN @ 80-100MHz
- Cross talk:
-40dB MIN @ 30MHz
-35dB MIN @ 60MHz
-30dB MIN @ 100MHz
- Common Mode Rejection:
-40dB MIN @ 30MHz
-35dB MIN @ 60MHz
-30dB MIN @ 100MHz
- Hipot Test: 1500Vrms
- Operating Temperature Range: -40°C TO +85°C

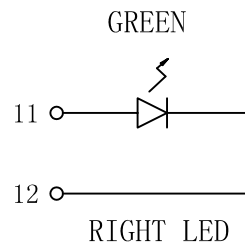
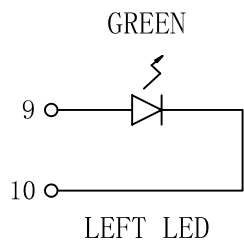

X:X ±0.25	APPD:	Trxcom ShenZhen Trxcom Electronics Co., ltd
X:XX ±0.20	CHKD:	
X:XXX ±0.05	DR: C. H. Y	TITLE: RJ45 Connector with 10/100 Base-T Integrated Magnetics
ANGLES ±1°	UNIT: mm	PART NO.: TRJ4012GFNL
	SCALE: 2/1	SHEET: 2/2
	REV: A	DWG NO.: TRC09083101



SUGGESTED PROFILE OF WAVE SOLDER FOR ROHS PRODUCT

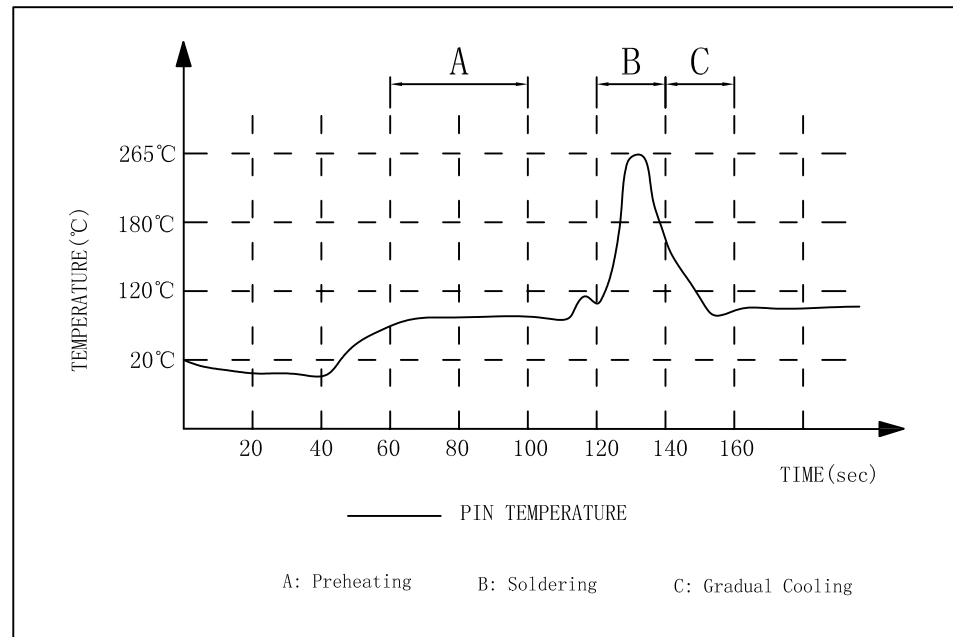

(1) Tip Temperature: 265°C max

(2) Tip Temperature time: 5sec max

Note: The melting point of Tin: 219°C

ShenZhen Trxcom Electronics Co., Ltd

PACKAGING

Part number: TRJ4012GFNL

1. Packaging unit: 60PCS/tray

2. Packaging material: PVC

3. Packaging shape: [Unit=cm]

4. Outer carton

Unit: 22Trays with plastic bag / outer carton (1320PCS) (G.W.:10 Kg)

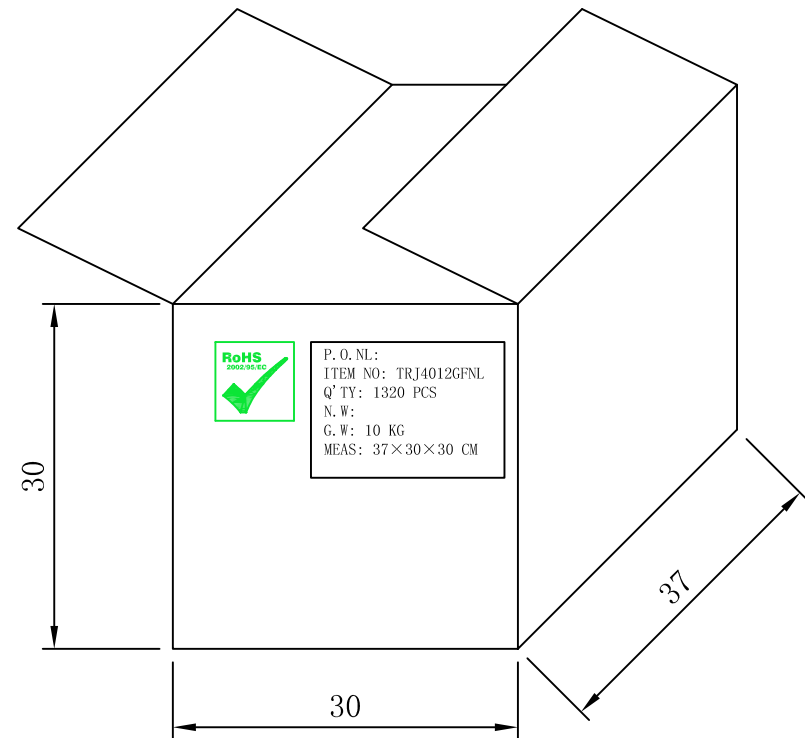
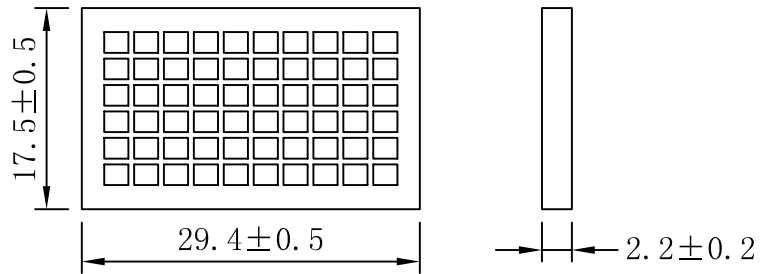

ORDER INFORMATION:
MOQ 5280PCS IN FOUR CTNS