

SPECIFICATION
 Q'ty:1000 PCS/Reel
 Reel:PVC,Size:φ330X30.4
 Tape:PVC,Size:20200X24.00X3.0mm
 RoHS Compliant

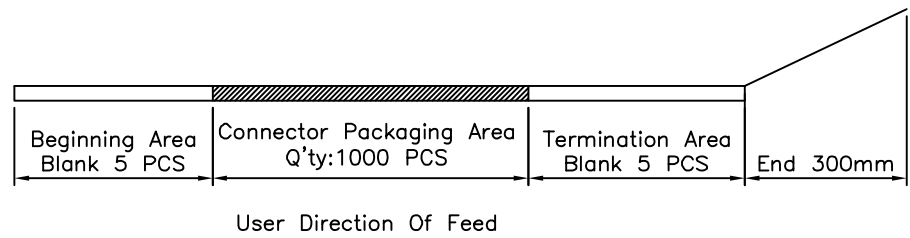

△ TFC 08 W P 0 1 F - SXX - R1K - H
 (1) (2) (3) (4) (5) (6) (7) (8) (9) (10)

- (1) TF:T-Flash Connector
- (2) 08:No. Of Position
- (3) W:SMT Right Angle
- (4) P:Push-Push Type
- (5) 0:Standoff 0mm
- (6) 1:Normal Type
- (7) F:Rear Solder Tail
- (8) SXX>Contact Finish
 Blank:Gold Flash On Contact Area
 Tin Plated On Solder Tail,Over Nickel
 S03:Gold Plated 3u" On Contact Area
 Tin Plated On Solder Tail,Over Nickel
- (9) R1K:Tape & Reel 1000 PCS/Reel
- (10) H:RoHS Compliant

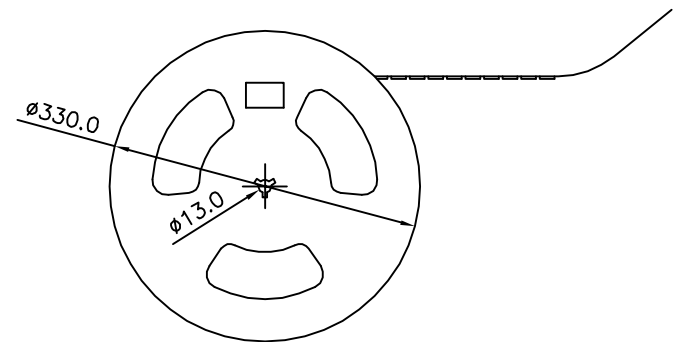
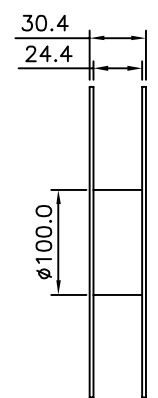

AUK A MEMBER OF AUK GROUP
太聯事業股份有限公司
AUK CONTRACTORS CO., LTD.

CATEGORY		APPROVED BY MEI		UNLESS OTHERWISE SPECIFIED TOLERANCES ARE .X ±0.25 .XX ±0.20 .XXX ±0.10 ANG. ±2°				
PART No. TFC08WP01F-SXX-R1K-H		CHECKED BY HZF						
DRAWING No. TFC08WP01F-SXX-R1K-H		DRAWING BY WSS			△ A1	Modify Data	HZF	05/16/2011
SCALE NONE		REV.	A1		UNIT mm	△ A0	NEW RELEASE	HZF
					NO.REV.	REVISIONS	CHK	DATE