

NO	DESCRIPTION	MATERIAL	Q'TY	FINISH	REMARK
1	BODY 1	BRASS	1	GOLD	B-SMA0086-G
2	BODY 2	BRASS	1	GOLD	B-SMB0795-G
3	INSULATION 1	TEFLON	1	TEFLON	I-0383T
4	PIN	BRASS	1	GOLD	P-SMB0554-G
5	INSULATION 2	TEFLON	1	TEFLON	I-0055T
6	WASHER	BRASS	1	GOLD	W-0009-G
7	NUT	BRASS	1	GOLD	N-0005-G

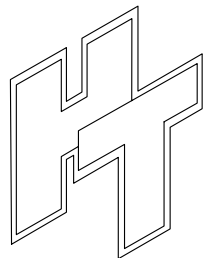
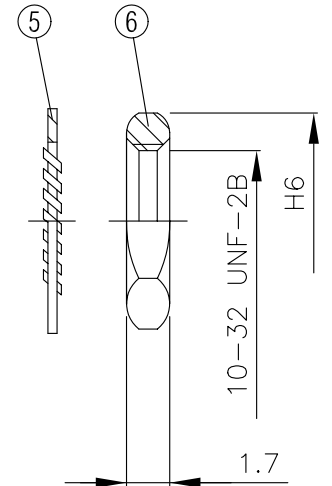
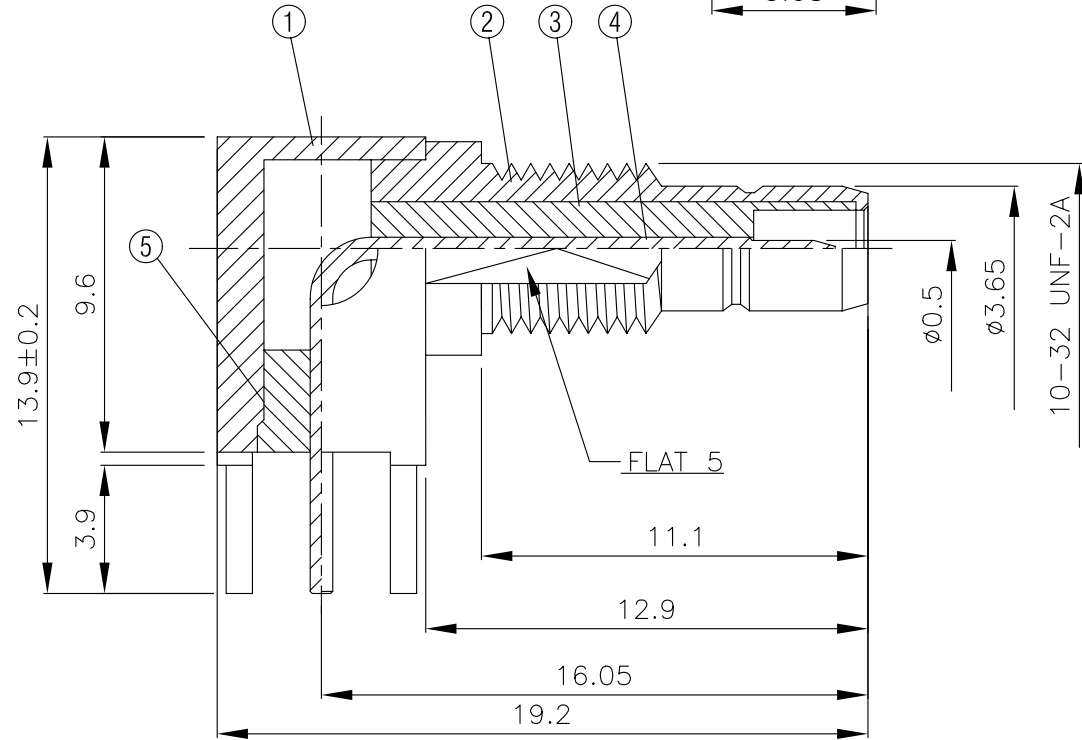
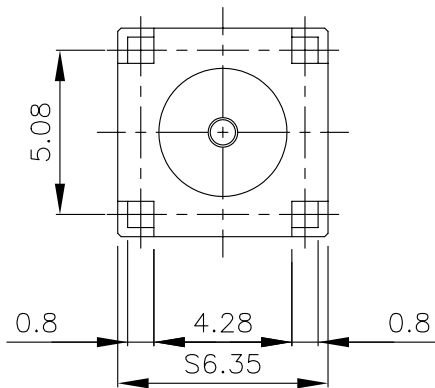
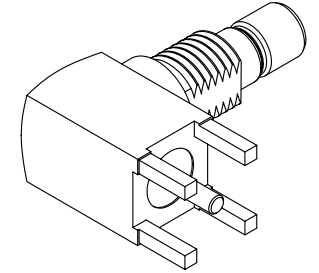
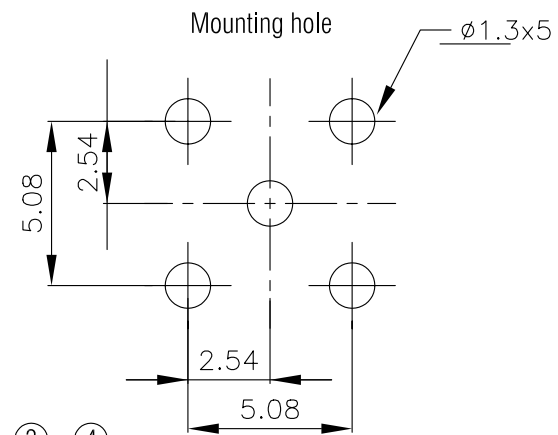

HUS-TSAN GROUP CO., LTD.
P.O.BOX 40-76.TAINAN.TAIWAN,R.O.C.
TITLE SMB ANGLE MALE FOR PCB MOUNT RECEPTACLE
PART NO. SMB-07V5-TGG
DRAWING NO. SMB 07V5 TGG

DRAWN	MARY	DATE	96.03.13
CHECKED	黃巧君	DATE	96.03.13
Q.A.	蘇姿潔	DATE	
APPROVAL	徐燦霖	DATE	
REVISION		DATE	

DIMENSIONS ARE IN MILLIMETERS			
UNLESS OTHERWISE SPECIFIED TOLERANCE			
0.5-5=±0.2	120-315=±1		
5-30= ±0.4	315-1000=±1.6		
30-120±0.6	1000-2000=±2.4		
SCALE	4:1	SIZE	A

REVISION	
DESCRIPTION	ENGINEER