

NO	DESCRIPTION	MATERIAL	Q' TY	FINISH	REMARK
1	SHELL	BRASS	1	GOLD	B-SMA0043-N
2	GASKET	SI RUBBER	1	RUBBER	RU-0008
3	WASHER	PH.BRONZE	1	GOLD	W-0012
4	BODY	BRASS	1	GOLD	B-SMA0821-G
5	INSULATION	TEFLON	1	TEFLON	I-0132T
6	PIN	BE CU	1	GOLD	

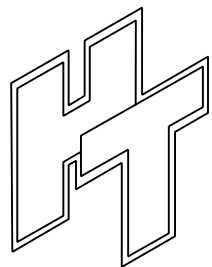
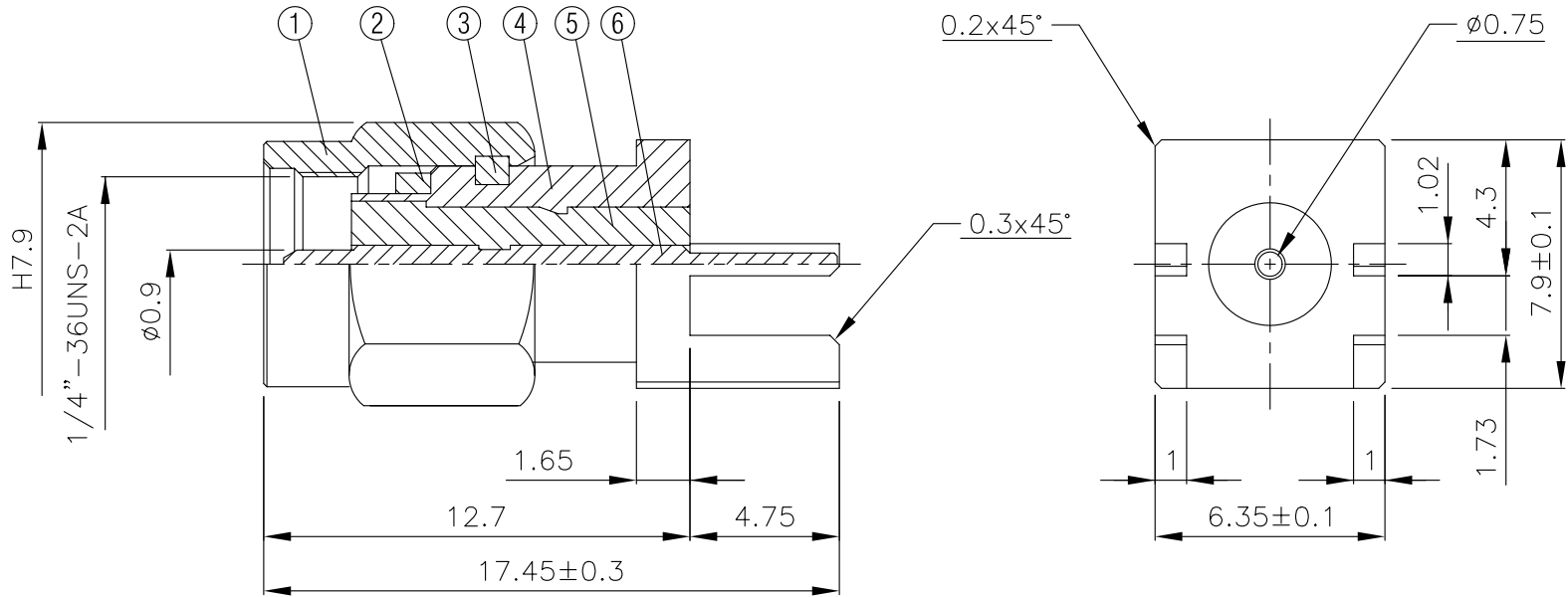
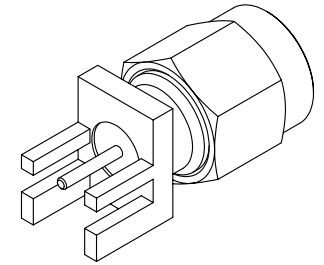

HUS-TSAN GROUP CO., LTD.

P.O. BOX 40-76. TAINAN, TAIWAN, R.O.C.

TITLE SMA MALE END LAUNCH
REVERSE POLARITY (1.57)

PART NO. SMA-50V7-TGG

DRAWING NO. SMA 50V7 TGG

DRAWN MARY DATE 96.03.27

CHECKED 蘇姿潔 DATE

Q.A. 馮健華 DATE

APPROVAL 徐燦霖 DATE

REVISION DATE

DIMENSIONS ARE IN MILLIMETERS

UNLESS OTHERWISE SPECIFIED
TOLERANCE

0.5-5=±0.2 120-315=±1

5-30=±0.4 315-1000=±1.6

30-120±0.6 1000-2000=±2.4

SCALE 4:1 SIZE A

REVISION

DESCRIPTION	ENGINEER