

NO	DESCRIPTION	MATERIAL	Q'TY	FINISH	REMARK
1	BODY	BRASS	1	GOLD	
2	INSULATION	TEFLON	1	TEFLON	I-0016T
3	PIN	BE CU	1	GOLD	P-SMA0098-G
4	NUT	BRASS	1	GOLD	N-0006-G
5	WASHER	BRASS	1	GOLD	W-0016-G

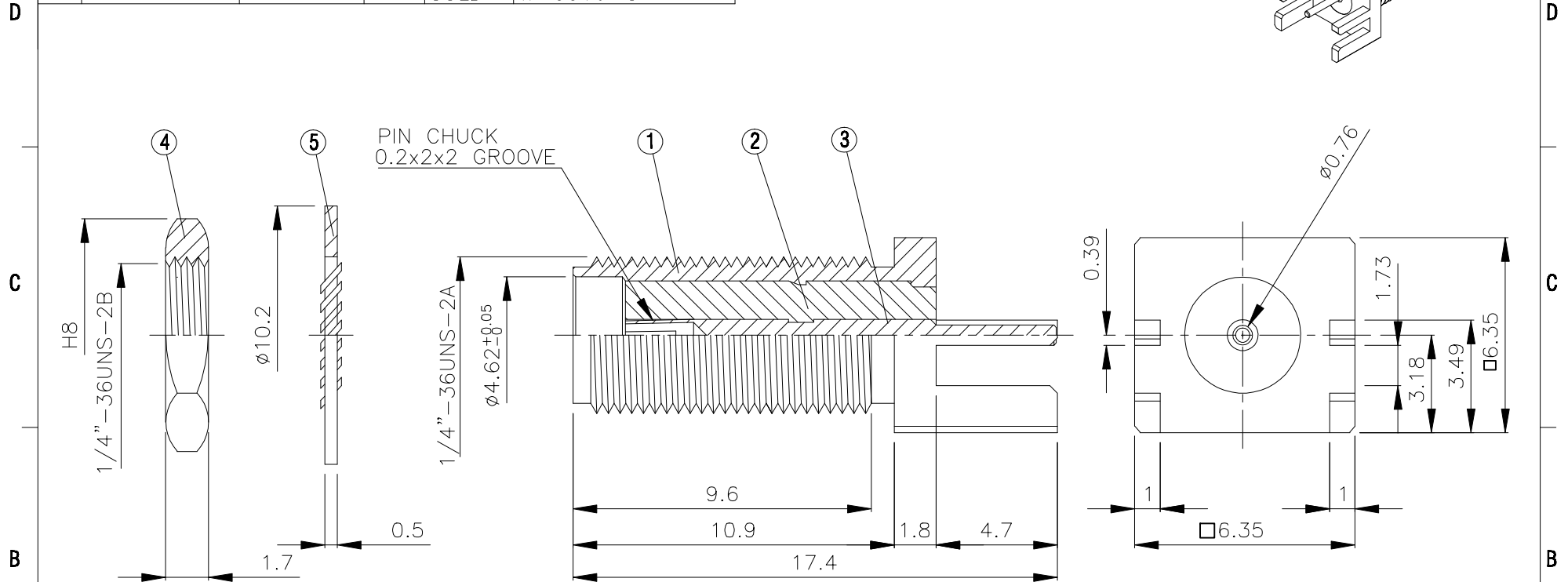
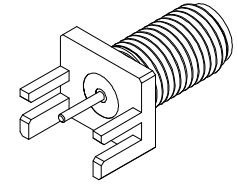

	HUS-TSAN GROUP CO., LTD. P.O. BOX 40-76. TAINAN. TAIWAN, R.O.C.		DRAWN 林孟翰 DATE 103.07.10	DIMENSIONS ARE IN MILLIMETERS		REVISION		
	TITLE SMA FEMALE END LAUNCH		CHECKED 林孟翰 DATE 103.07.10	UNLESS OTHERWISE SPECIFIED TOLERANCE		DESCRIPTION	ENGINEER	
	PART NO. SMA-10V49-TGG		Q.A. 莊千慧 DATE	0.5-5 = ±0.2 120-315 = ±1				
	DRAWING NO. SMA 10V49 TGG		APPROVAL 徐燦霖 DATE	5-30 = ±0.4 315-1000 = ±1.6				
			REVISION DATE	30-120 = ±0.6 1000-2000 = ±2.4	SCALE 4:1	SIZE A		