

NO	DESCRIPTION	MATERIAL	Q'TY	FINISH	REMARK
1	NUT	BRASS	1	GOLD	N-0006-G
2	WASHER	BRASS	1	GOLD	W-0016-G
3	GASKET	SI RUBBER	1	RUBBER	RU-0014
4	INSULATION	TEFLON	1	TEFLON	I-0131T
5	BODY	BRASS	1	GOLD	B-SMA0205-G
6	PIN	BE CU	1	GOLD	P-SMA0635-G
7	INSULATION	TEFLON	1	TEFLON	I-0256T
8	BODY	BRASS	1	GOLD	B-SMA0902-G

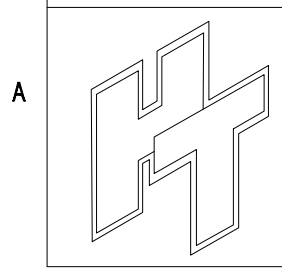
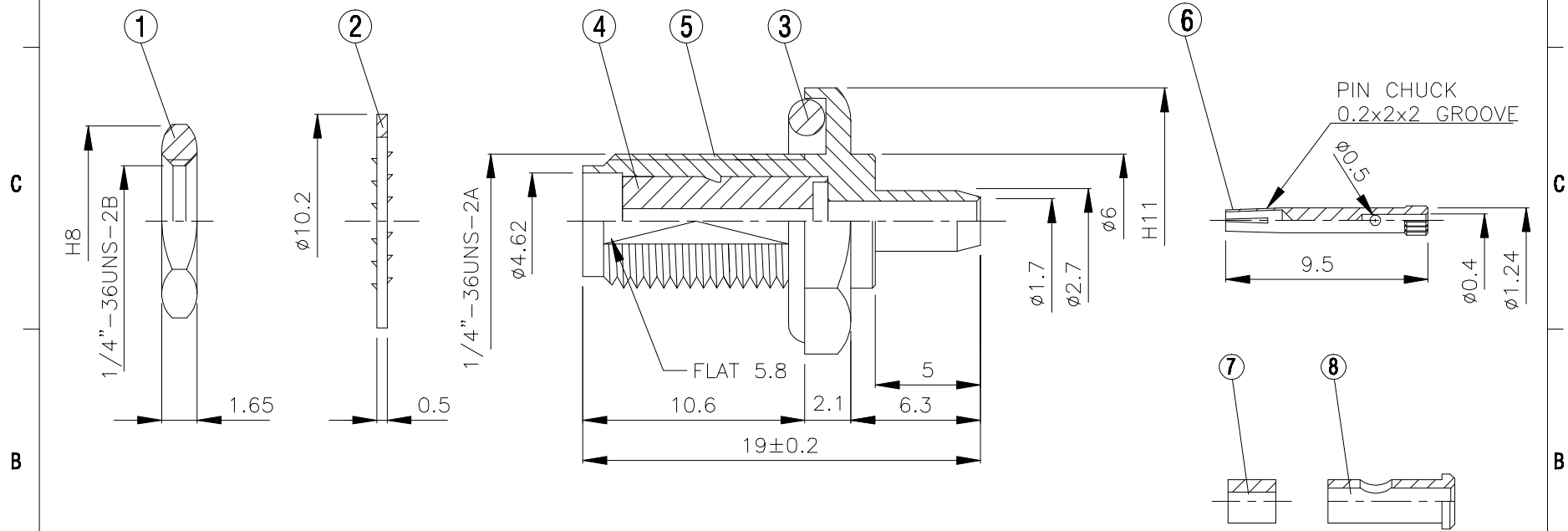
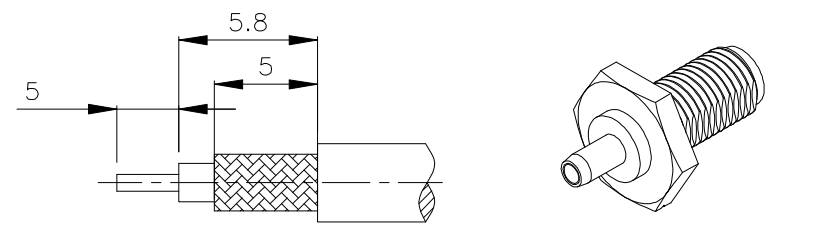

HUS-TSAN GROUP CO., LTD.
P.O.BOX 40-76.TAINAN.TAIWAN,R.O.C.
TITLE SMA FEMALE CRIMP FOR HRS 1.3mm
PART NO. SMA-05U-TGG
DRAWING NO. SMA 05U TGG

DRAWN MARY **DATE 96.03.15**
CHECKED 蘇姿潔 **DATE**
Q.A. 馮健華 **DATE**
APPROVA 徐燦霖 **DATE**
REVISION **DATE**

DIMENSIONS ARE IN MILLIMETERS
UNLESS OTHERWISE SPECIFIED TOLERANCE
0.5-5=±0.2 120-315=±1
5-30= ±0.4 315-1000=±1.6
30-120=±0.6 1000-2000=±2.4
SCALE 4:1 **SIZE A**

REVISION	
DESCRIPTION	ENGINEER