

NO	DESCRIPTION	MATERIAL	Q'TY	FINISH	REMARK
1	NUT	BRASS	1	NICKEL	N-0006-G
2	WASHER	BRASS	1	NICKEL	W-0016-G
3	GASKET	SI RUBBER	1	RUBBER	RU-0014
4	INSULATION	TEFLON	1	TEFLON	I-0131T
5	BODY	BRASS	1	NICKEL	B-SMA0205-N
6	PIN	BE CU	1	GOLD	P-SMA0635-G
7	INSULATION	TEFLON	1	TEFLON	I-0256T
8	BODY	BRASS	1	NICKEL	B-SMA0473-N

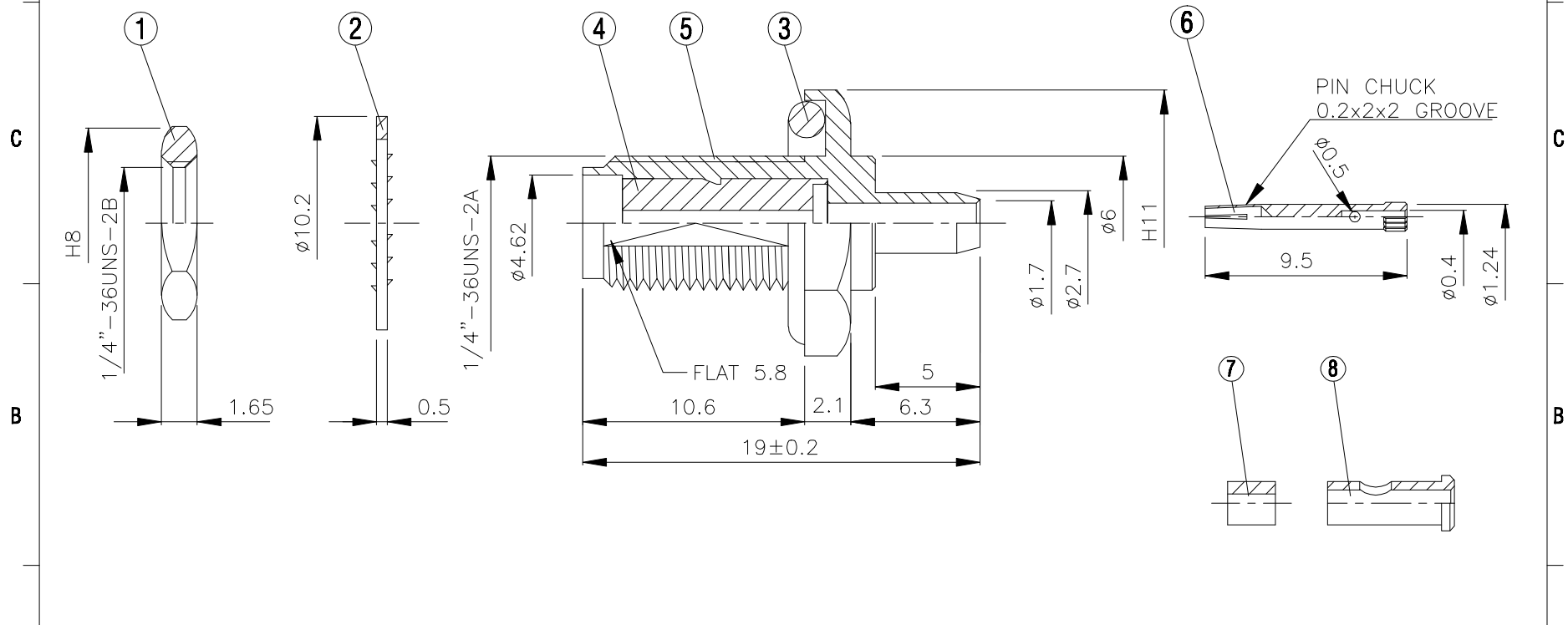
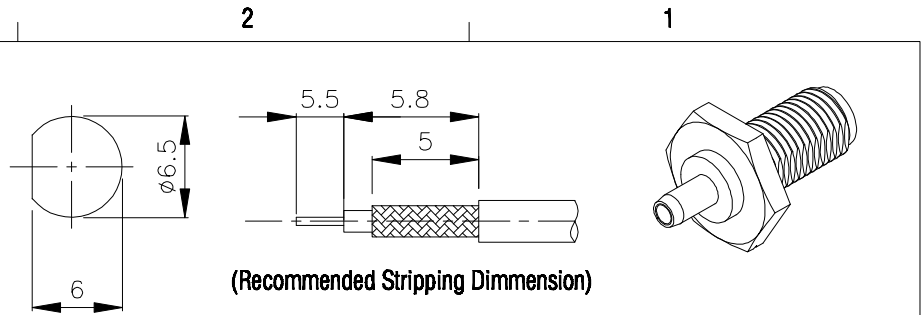

	HUS-TSAN GROUP CO., LTD.		DRAWN	MARY	DATE	96.03.19		DIMENSIONS ARE IN MILLIMETERS		REVISION	
	P.O.BOX 40-76.TAINAN.TAIWAN,R.O.C.		CHECKED	蘇姿潔	DATE			UNLESS OTHERWISE SPECIFIED TOLERANCE		DESCRIPTION	ENGINEER
	TITLE SMA FEMALE CRIMP FOR 178/U		Q.A.	馮健華	DATE			0.5-5=±0.2	120-315=±1		
	PART NO. SMA-05M-TGG		APPROVA	徐燦霖	DATE			5-30= ±0.4	315-1000=±1.6		
	DRAWING NO. SMA 05M TGG		REVISION		DATE			30-120=±0.6	1000-2000=±2.4		
					SCALE	4:1	SIZE	A			