

NO	DESCRIPTION	MATERIAL	Q'TY	FINISH	REMARK
1	NUT	BRASS	1	NICKEL	N-0006
2	WASHER	BRASS	1	NICKEL	W-0016
3	GASKET	SI RUBBER	1	RUBBER	RU-0014
4	INSULATION	TEFLON	1	TEFLON	I-0131T
5	BODY	BRASS	1	NICKEL	B-SMA0090-N
6	PIN	BE CU	1	GOLD	P-SMA0056-G
7	RING	BRASS	1	NICKEL	R-0002

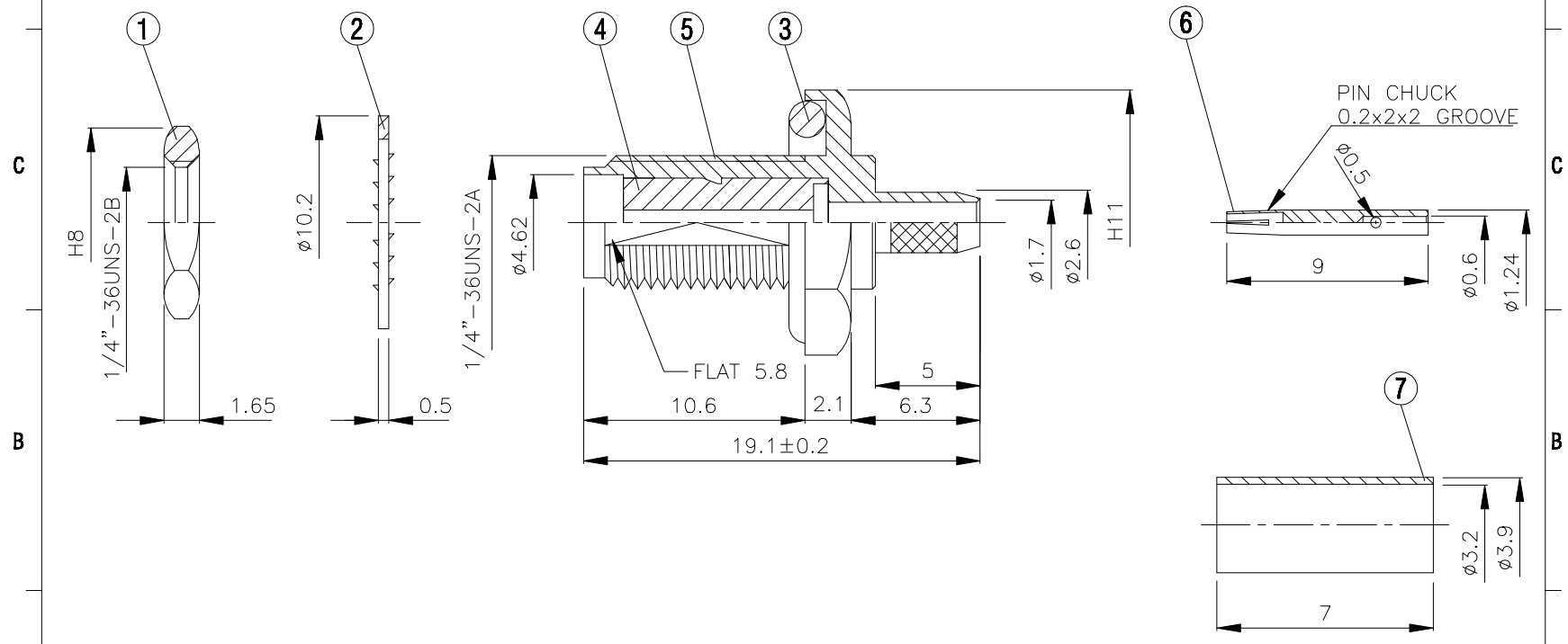
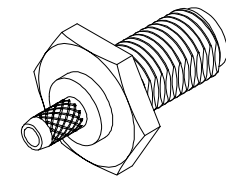
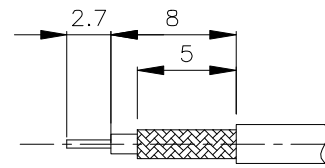

	<b>HUS-TSAN GROUP CO., LTD.</b> P.O. BOX 40-76. TAINAN. TAIWAN, R.O.C.		DRAWN MARY DATE 90.01.22	DIMENSIONS ARE IN MILLIMETERS UNLESS OTHERWISE SPECIFIED TOLERANCE		REVISION	
	TITLE SMA FEMALE CRIMP FOR RG-316/U		CHECKED 蘇志欣 DATE 97.07.08	0.5-5 = $\pm 0.2$ 120-315 = $\pm 1$ 5-30 = $\pm 0.4$ 315-1000 = $\pm 1.6$ 30-120 = $\pm 0.6$ 1000-2000 = $\pm 2.4$		DESCRIPTION	ENGINEER
	PART NO. SMA-05LV1-TGN		Q.A. 蘇姿潔 DATE	SCALE 4:1    SIZE A			
	DRAWING NO. SMA 05LV1 TGN		APPROVAL 徐燦霖 DATE				
			REVISION DATE				