

NO	DESCRIPTION	MATERIAL	Q'TY	FINISH	REMARK
1	SHELL	BRASS	1	GOLD	B-SMA0043-G
2	GASKET	SI RUBBER	1	RUBBER	RU-0008
3	INSULATION	TEFLON	1	TEFLON	I-0115T
4	WASHER	PH.BRONZE	1	GOLD	W-0012
5	BODY	BRASS	1	GOLD	B-SMA0042-G
6	PIN	BRASS	1	GOLD	P-SMA0037-G

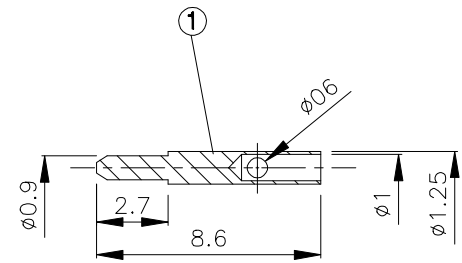
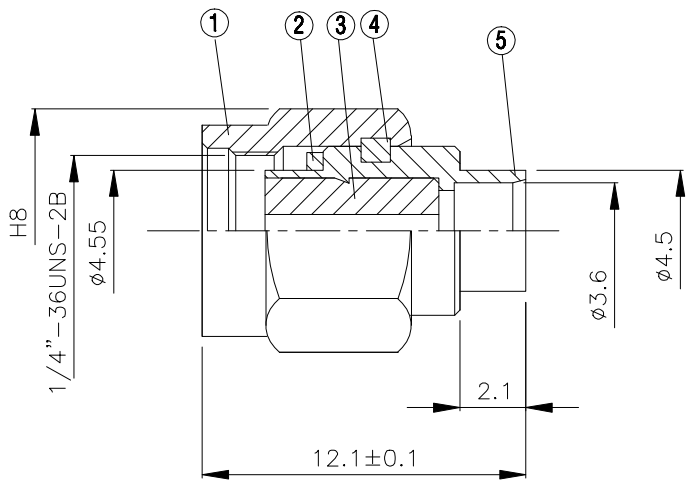
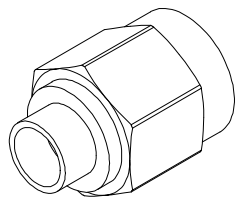
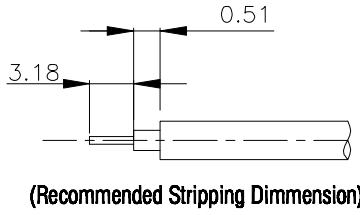

D

D

C

C

B

B

A

A

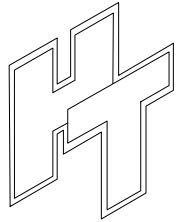

HUS-TSAN GROUP CO., LTD.
P.O.BOX 40-76.TAINAN.TAIWAN,R.O.C.
TITLE SMA MALE SOLDER FOR RG402 (.141)
PART NO. SMA-03V2-TGG
DRAWING NO. SMA 03V2 TGG

DRAWN MARY **DATE 90.02.22**
CHECKED 蘇志欣 **DATE 97.07.02**
Q.A. 蘇姿潔
APPROVAL 徐燦霖
REVISION **DATE**

DIMENSIONS ARE IN MILLIMETERS
UNLESS OTHERWISE SPECIFIED TOLERANCE
0.5-5=±0.2 120-315=±1
5-30= ±0.4 315-1000=±1.6
30-120±0.6 1000-2000=±2.4
SCALE 4:1 **SIZE A**

REVISION	
DESCRIPTION	ENGINEER

4

3

2

1