

REV.	DESCRIPTION	DRAWN	CHECKED	APPROVED
A	NEW RELEASE	LL 11/15/06'		

NOTES:

1. MATERIALS

- . Insulator: thermoplastic, UL 94V-0 Rated
- . Contacts: Copper Alloy
- . Shell: Copper Alloy

2. SPECIFICATION

- . Contact resistance: 50mΩ max.
- . Insulation resistance: 100MΩ min.
- . Dielectric withstanding voltage: 100 VAC 1 minute.
- . Temperature range: -40°C to +105°C.

3. PRODUCT NUMBER CODE:

DS1117 - X X X

- Contact plating
 - 0: selective gold flash
 - C: selective 3u" gold
 - 1: selective 10u" gold
- Shell plating
 - 8: Full Gold Flash
 - 6: Tin
 - N: Nickel
- Color of housing
 - B: Black

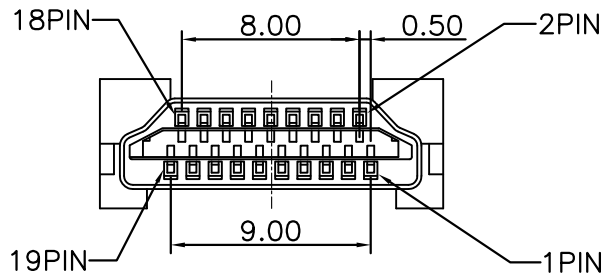
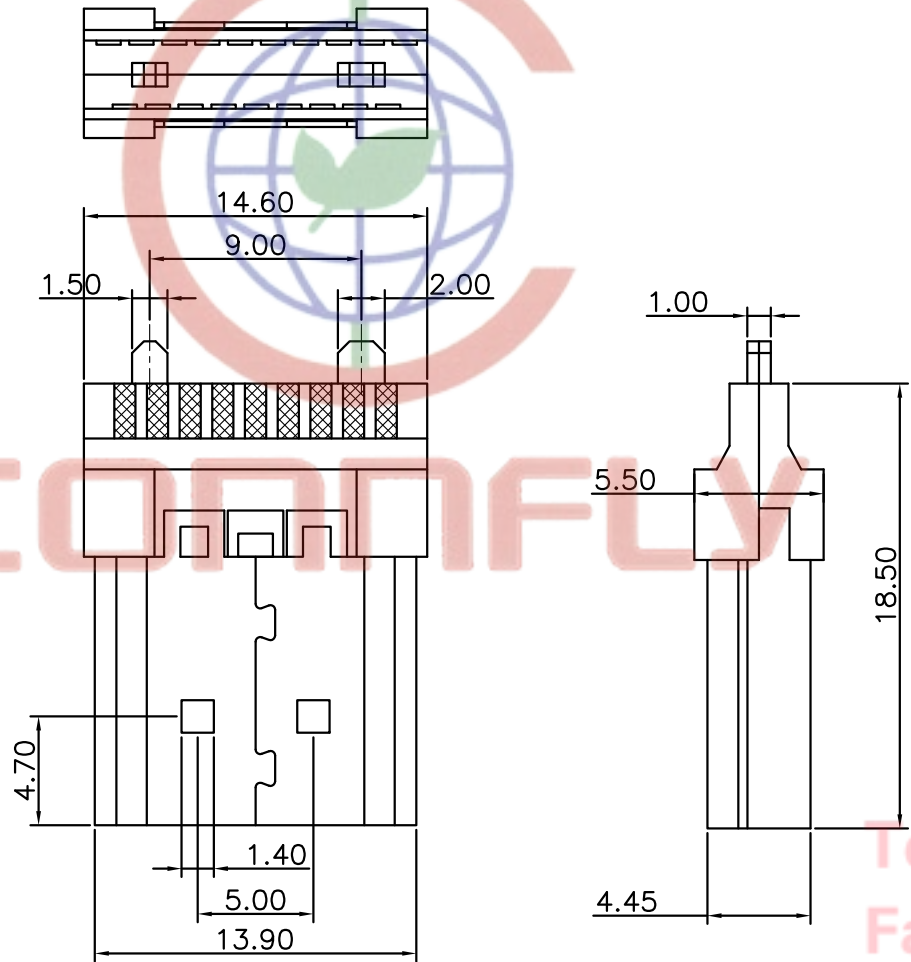

GENERAL TOLERANCE	ANGLE TOLERANCE	PROJECTION	TITLE
X. ±0.60	X. ±5°	UNITS mm	HDMI 19PIN MALE Solder type
.X ±0.38	.X ±3°	SHEET SIZE A4	SERIES DS1117
.XX ±0.25	.XX ±2°		
DRAWING TYPE	CUSTOMER	 晨翔电子有限公司 CONNFLY CONNFLY ELECTRONIC CO. LTD	
SCALE	1:1 SHEET 1 OF 1		
DRAWING NO.	C-DS1117-XXX		

Tel:86-574-63508787
 Fax:86-574-63510817
 E-mail:sale@zhenqin.com.cn
 Http://www.connfly.com