

REV.	DESCRIPTION	DRAWN	CHECKED	APPROVED
A	NEW RELEASE	LL 01/22/07'	~	LJC 01/22/07'
B	整理图面	YCH 07/12/07'	~	LJC 07/12/07'
C	加长度规格	YCH 07/16/08'	~	

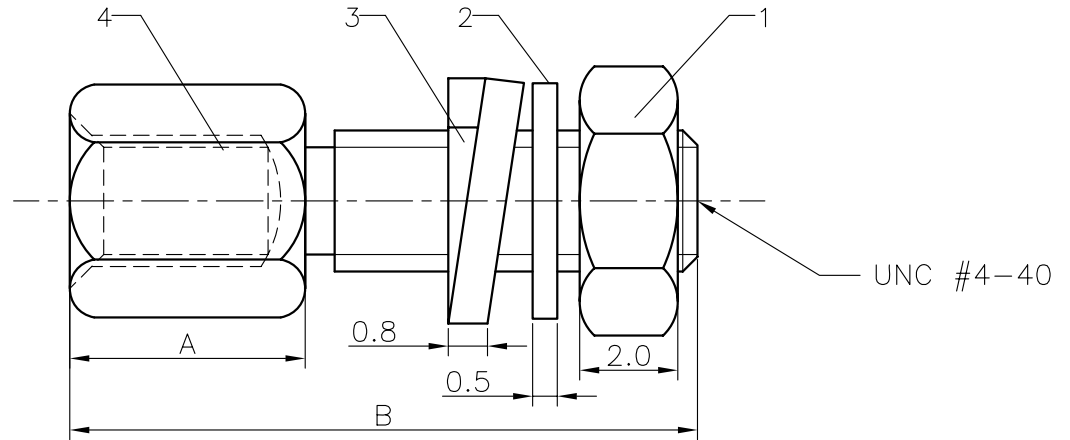
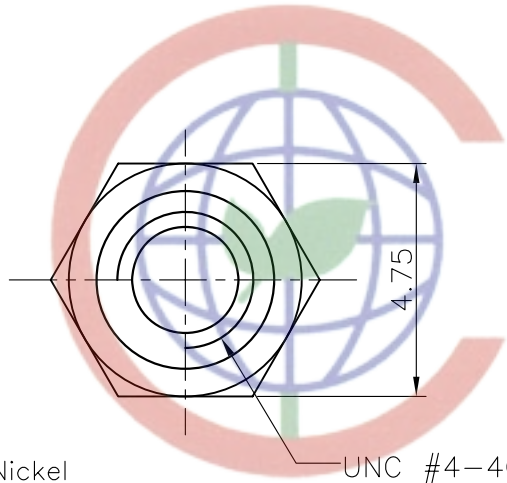

NOTES:

1. Plating: Nickel
2. Product Number Code

DS1045-01 - X X X

Components support:

- 1: W/O screw 1
- 2: W/O washer 2
- 3: W/O split washer 3
- 4: standard (W/ 1 2 3)
- 5: W/O washer 2 and split washer 3
- X: W/O 1 2 3

Dim. A type:

- 0480: 4.80mm
- 0580: 5.80mm

Dim. B type:

- 1180: 11.8mm
- 1200: 12.0mm
- 1280: 12.8mm
- 1780: 17.8mm
- 1570: 15.7mm
- 1880: 18.8mm
- 1000: 10.0mm

Tel:86-574-63508787

Fax:86-574-63510817

E-mail:sale@zhenqin.com.cn

Http://www.connfly.com

				GENERAL TOLERANCE	ANGLE TOLERANCE	PROJECTION	TITLE
4	BOLT		Steel	NICKEL	X. ±0.20	X. ±2°	SCREW ASSEMBLY
3	SPLIT WASHER	W-C0550-0080-2	Steel	NICKEL	.X ±0.15	.X ±1°	
2	WASHER	W-C0550-0050-1	Steel	NICKEL	.XX ±0.10	.XX ±0.5°	
1	NUT	N-L0475-0200-04	Steel	NICKEL	DRAWING TYPE CUSTOMER		SERIES DS1045-01 SERIES
ITEM	PART NAME	PART NO.	MATERILAS	FINISHED	SCALE	1:1 SHEET 1 OF 1	
				DRAWING NO.	C-DS1045-01-XXX-C		



晨翔电子有限公司

CONNFLY CONNFLY ELECTRONIC CO. LTD