

TFT COLOR LCD MODULE

NL3224BC35-22

**14cm (5.5 Type)
QVGA**

DATA SHEET 

DOD-PP-1056 (7th edition)

**This DATA SHEET is updated document from
DOD-PP-0301(6).**

**All information is subject to change without notice.
Please confirm the sales representative before
starting to design your system.**

INTRODUCTION

The Copyright to this document belongs to NEC LCD Technologies, Ltd. (hereinafter called "NEC"). No part of this document will be used, reproduced or copied without prior written consent of NEC.

NEC does and will not assume any liability for infringement of patents, copyrights or other intellectual property rights of any third party arising out of or in connection with application of the products described herein except for that directly attributable to mechanisms and workmanship thereof. No license, express or implied, is granted under any patent, copyright or other intellectual property right of NEC.

Some electronic parts/components would fail or malfunction at a certain rate. In spite of every effort to enhance reliability of products by NEC, the possibility of failures and malfunction might not be avoided entirely. To prevent the risks of damage to death, human bodily injury or other property arising out thereof or in connection therewith, each customer is required to take sufficient measures in its safety designs and plans including, but not limited to, redundant system, fire-containment and anti-failure.

The products are classified into three quality grades: "**Standard**", "**Special**", and "**Specific**" of the highest grade of a quality assurance program at the choice of a customer. Each quality grade is designed for applications described below. Any customer who intends to use a product for application other than that of Standard quality grade is required to contact an NEC sales representative in advance.

The **Standard** quality grade applies to the products developed, designed and manufactured in accordance with the NEC standard quality assurance program, which are designed for such application as any failure or malfunction of the products (sets) or parts/components incorporated therein a customer uses are, directly or indirectly, free of any damage to death, human bodily injury or other property, like general electronic devices.

Examples: Computers, office automation equipment, communications equipment, test and measurement equipment, audio and visual equipment, home electronic appliances, machine tools, personal electronic equipment, industrial robots, etc.

The **Special** quality grade applies to the products developed, designed and manufactured in accordance with an NEC quality assurance program stricter than the standard one, which are designed for such application as any failure or malfunction of the products (sets) or parts/components incorporated therein a customer uses might directly cause any damage to death, human bodily injury or other property, or such application under more severe condition than that defined in the Standard quality grade without such direct damage.

Examples: Control systems for transportation equipment (automobiles, trains, ships, etc.), traffic control systems, anti-disaster systems, anti-crime systems, medical equipment not specifically designed for life support, safety equipment, etc.

The **Specific** quality grade applies to the products developed, designed and manufactured in accordance with the standards or quality assurance program designated by a customer who requires an extremely higher level of reliability and quality for such products.

Examples: Military systems, aircraft control equipment, aerospace equipment, nuclear reactor control systems, medical equipment/devices/systems for life support, etc.

The quality grade of this product is the "**Standard**" unless otherwise specified in this document.

CONTENTS

INTRODUCTION 2

1. OUTLINE 4

 1.1 STRUCTURE AND PRINCIPLE 4

 1.2 APPLICATION 4

 1.3 FEATURES 4

2. GENERAL SPECIFICATIONS 5

3. BLOCK DIAGRAM 6

4. DETAILED SPECIFICATIONS 8

 4.1 MECHANICAL SPECIFICATIONS 8

 4.2 ABSOLUTE MAXIMUM RATINGS 8

 4.3 ELECTRICAL CHARACTERISTICS 9

 4.3.1 LCD panel signal processing board 9

 4.3.2 Backlight lamp 10

 4.3.3 Power supply voltage ripple 11

 4.3.4 Fuse 11

 4.4 POWER SUPPLY VOLTAGE SEQUENCE 12

 4.4.1 LCD panel signal processing board 12

 4.4.2 Inverter 12

 4.5 CONNECTIONS AND FUNCTIONS FOR INTERFACE PINS 13

 4.5.1 LCD panel signal processing board 13

 4.5.2 Backlight lamp 14

 4.5.3 Positions of plugs and a socket 14

 4.6 DISPLAY COLORS AND INPUT DATA SIGNALS 15

 4.7 DISPLAY POSITIONS 16

 4.8 SCANNING DIRECTIONS 16

 4.8.1 QVGA mode 16

 4.8.2 VGA mode 17

 4.9 INPUT SIGNAL TIMINGS 18

 4.9.1 QVGA mode 18

 4.9.2 VGA mode 24

 4.10 OPTICS 30

 4.10.1 Optical characteristics 30

 4.10.2 Definition of contrast ratio 31

 4.10.3 Definition of luminance uniformity 31

 4.10.4 Definition of response times 31

 4.10.5 Definition of viewing angles 31

5. ESTIMATED LUMINANCE LIFETIME 32

6. RELIABILITY TESTS 33

7. PRECAUTIONS 34

 7.1 MEANING OF CAUTION SIGNS 34

 7.2 CAUTIONS 34

 7.3 ATTENTIONS 34

 7.3.1 Handling of the product 34

 7.3.2 Environment 35

 7.3.3 Characteristics 35

 7.3.4 Other 36

8. OUTLINE DRAWINGS 37

 8.1 FRONT VIEW 37

 8.2 REAR VIEW 38

1. OUTLINE

1.1 STRUCTURE AND PRINCIPLE

Color LCD module NL3224BC35-22 is composed of the amorphous silicon thin film transistor liquid crystal display (a-Si TFT LCD) panel structure with driver LSIs for driving the TFT (Thin Film Transistor) array and a backlight.

The a-Si TFT LCD panel structure is injected liquid crystal material into a narrow gap between the TFT array glass substrate and a color-filter glass substrate.

Color (Red, Green, Blue) data signals from a host system (e.g. signal generator, etc.) are modulated into best form for active matrix system by a signal processing circuit, and sent to the driver LSIs which drive the individual TFT arrays.

The TFT array as an electro-optical switch regulates the amount of transmitted light from the backlight assembly, when it is controlled by data signals. Color images are created by regulating the amount of transmitted light through the TFT array of red, green and blue dots.

1.2 APPLICATION

- For industrial use

1.3 FEATURES

- Adoption of ST-NLT (Super-Transmissive Natural Light TFT)
- High luminance
- Wide color gamut
- Wide viewing angle
- Low reflection
- 6-bit digital RGB signals
- Reversible-scan direction
- Selectable QVGA or VGA mode
- Edge light type (without inverter)
- Replaceable lamp for backlight
- Acquisition product for UL60950-1/CSA-C22.2 No.60950-1-03 (File number: E170632)
- Compliance with the European RoHS directive (2002/95/EC)
(From product which was produced after April. 1, 2006)

2. GENERAL SPECIFICATIONS

Display area	111.36 (H) × 83.52 (V) mm
Diagonal size of display	14cm (5.5 inches)
Drive system	a-Si TFT active matrix
Display color	262,144 colors
Pixel	320 (H) × 240 (V) pixels
Pixel arrangement	RGB (Red dot, Green dot, Blue dot) vertical stripe
Dot pitch	0.116 (H) × 0.348 (V) mm
Pixel pitch	0.348 (H) × 0.348 (V) mm
Module size	134.0 (W) × 104.5 (H) × 12.5 (D) mm (typ.)
Weight	215g (typ.)
Contrast ratio Note1	500:1 (typ.)
Viewing angle Note1	At the contrast ratio ≥ 10:1 <ul style="list-style-type: none"> • Horizontal: Right side 55° (typ.), Left side 55° (typ.) • Vertical: Up side 50° (typ.), Down side 40° (typ.)
Designed viewing direction	At DPSH, DPSV= Low or Open: Normal scan <ul style="list-style-type: none"> • Viewing direction without image reversal: Down side (6 o'clock) • Viewing direction with contrast peak: Up side (12 o'clock) • Viewing angle with optimum grayscale ($\gamma \approx 2.2$): Normal axis (perpendicular)
Polarizer surface	Clear + Antireflection (AR)
Polarizer pencil-hardness	2H (min.) [by JIS K5400]
Color gamut	At LCD panel center 50% (typ.) [against NTSC color space]
Response time	Ton+Toff (10%←→90%) 30ms (typ.)
Luminance	At IBL= 5.0mAmps / lamp 750cd/m ² (typ.)
Signal system	6-bit digital signals for data of RGB colors, Dot clock (CLK), Data enable (DE), Horizontal synchronous signal (Hsync), Vertical synchronous signal (Vsync)
Power supply voltage	LCD panel signal processing board: 3.3V or 5.0V
Backlight	Edge light type: 2 cold cathode fluorescent lamps <div style="margin-left: 20px;"> (Replaceable part) <ul style="list-style-type: none"> • Lamp holder set: Type No. 55LHS11 </div> <div style="margin-left: 20px;"> (Recommended inverter (Option)) <ul style="list-style-type: none"> • Inverter: Type No. 55PW131 </div>
Power consumption Note1	At IBL= 5.0mAmps / lamp, Checkered flag pattern 3.8W (typ., Power dissipation of the inverter is not included.)

Note1: At QVGA mode



Note1: Relations between GND (Signal ground), shield plate and VBLC (Lamp low voltage terminal) in the LCD module are as follows.

Front shield plate - Rear shield plate	Not connected
GND - Front shield plate and Rear shield plate	Not connected
VBLC - Front shield plate and Rear shield plate	Not connected
GND - VBLC	Not connected

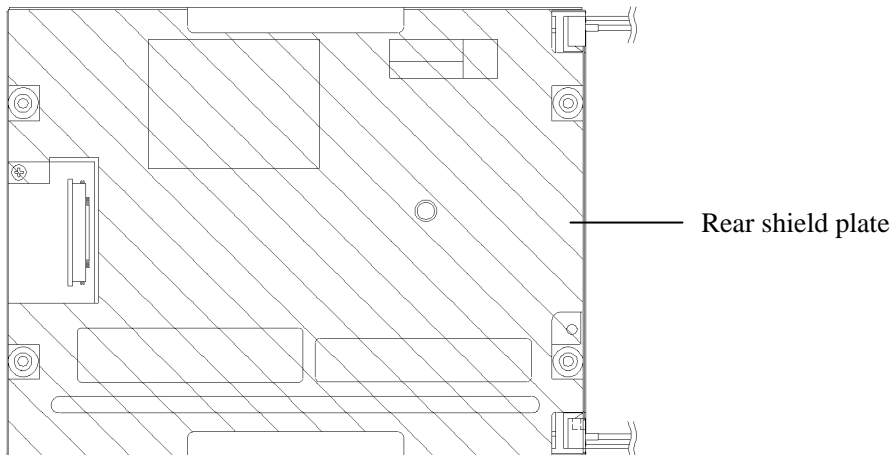
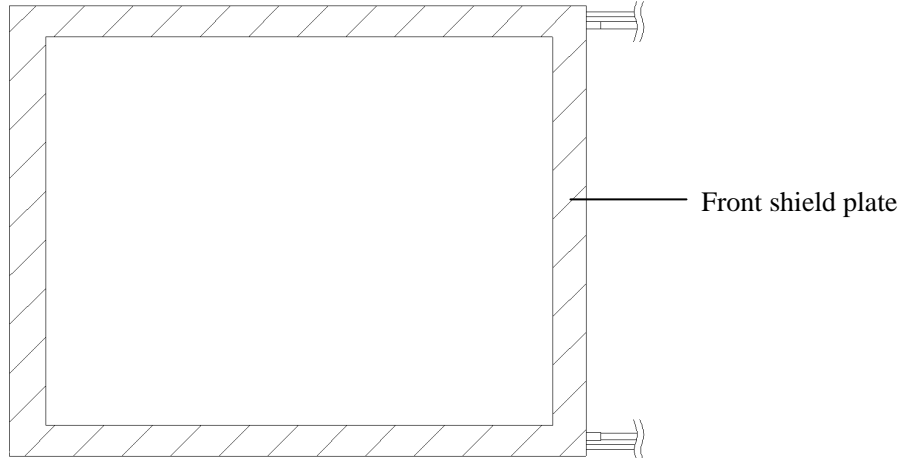

Note2: GND and GNDB must be connected to customer equipment's ground, and it is recommended that these grounds are connected together in customer equipment.

Note3: Pull-down resistance of DPSH pin

Power supply voltage VCC	Pull-down resistance of DPSH pin (kΩ)		
	min.	typ.	max.
at 3.3V	8.2	13.0	18.3
at 5.0V	6.0	10.0	15.0

Note4: Pull-down resistance of DPSV pin and Q/V pin

Power supply voltage VCC	Pull-down resistance of DPSV pin and Q/V pin (kΩ)		
	min.	typ.	max.
at 3.3V	13.0	18.3	23.0
at 5.0V	10.0	15.0	20.0

4. DETAILED SPECIFICATIONS

4.1 MECHANICAL SPECIFICATIONS

Parameter	Specification	Unit
Module size	134.0 ± 0.5 (W) × 104.5 ± 0.5 (H) × 12.5 ± 0.5 (D) Note1	mm
Display area	111.36 (H) × 83.52 (V) Note1	mm
Weight	215 (typ.), 225 (max.)	g

Note1: See "8. OUTLINE DRAWINGS".

4.2 ABSOLUTE MAXIMUM RATINGS

Parameter		Symbol	Rating	Unit	Remarks	
Power supply voltage	LCD panel signal processing board	VCC	-0.3 to +6.5	V	Ta= 25°C	
	Lamp voltage	VBLH	1,500	Vrms		
Input voltage for signals	Display signals Note1	VD	-0.3 to VCC+0.3	V		
	Function signals Note2	VF				
Incident light intensity		II	150,000	lx		Note3
Storage temperature		Tst	-30 to +80	°C		-
Operating temperature	Front surface	TopF	-10 to +70	°C	Note4	
	Rear surface	TopR	-10 to +75	°C	Note5	
Relative humidity Note6		RH	≤ 95	%	Ta ≤ 40°C	
			≤ 85	%	40 < Ta ≤ 50°C	
			≤ 70	%	50 < Ta ≤ 55°C	
			≤ 60	%	55 < Ta ≤ 60°C	
			≤ 50	%	60 < Ta ≤ 65°C	
			≤ 42	%	65 < Ta ≤ 70°C	
Absolute humidity Note6		AH	≤ 83 Note7	g/m ³	Ta > 70°C	

Note1: CLK, Hsync, Vsync, DE, DATA (R0 to R5, G0 to G5, B0 to B5)

Note2: DPSH, DPSV, Q/V

Note3: If the product surface (polarizer) is exposed to an ultraviolet ray, the polarizer may discolor (Surface treatment may be damaged.). Use a filter to protect the polarizer from the ultraviolet ray.

Note4: Measured at center of LCD panel surface (including self-heat)

Note5: Measured at center of LCD module's rear shield surface (including self-heat)

Note6: No condensation

Note7: Water amount at Ta= 70°C and RH= 42%

4.3 ELECTRICAL CHARACTERISTICS

4.3.1 LCD panel signal processing board

(Ta= 25°C)

Parameter	Symbol	min.	typ.	max.	Unit	Remarks	
Power supply voltage	VCC	3.0	3.3	3.6	V	at VCC= 3.3V	
		4.75	5.0	5.25	V	at VCC= 5.0V	
Power supply current	QVGA mode	ICC	-	65 Note1	105 Note2	mA	at VCC= 3.3V
			-	50 Note1	85 Note2	mA	at VCC= 5.0V
	VGA mode		-	95 Note1	175 Note2	mA	at VCC= 3.3V
			-	70 Note1	130 Note2	mA	at VCC= 5.0V
Logic input voltage for display signals	High	VDLH	0.7VCC	-	VCC	CMOS level	
	Low	VDLL	0	-	0.3VCC		
Input voltage for DPSH, DPSV and Q/V signal	High	VFDH	0.7VCC	-	VCC	-	
	Low	VFDL	0	-	0.9		

Note1: Checkered flag pattern [by EIAJ ED-2522]

Note2: Pattern for maximum current

4.3.2 Backlight lamp

(Ta= 25°C, Note1)

Parameter	Symbol	min.	typ.	max.	Unit	Remarks
Lamp current Note3	IBL	4.5	5.0	5.5	mArms	at IBL= 5.0mArms: L= 750cd/m ²
Lamp voltage Note2, Note3	VBLH	-	350	-	Vrms	-
Lamp starting voltage Note2, Note3, Note4, Note7	VS	550	-	-	Vrms	Ta= 25°C
		780	-	-	Vrms	Ta= -10°C
Lamp oscillation frequency Note5	FO	39	43	47	kHz	-

Note1: This product consists of 2 backlight lamps, and these specifications are for each lamp.

Note2: The lamp voltage cycle between lamps should be kept on a same phase. "VS" and "VBLH" are the voltage value between low voltage side (Cold) and high voltage side (Hot).

Note3: The asymmetric ratio of working waveform for lamps (Power supply voltage peak ratio, power supply current peak ratio and waveform space ratio) should be less than 5 % (See the following figure.). If the waveform is asymmetric, DC (Direct current) element apply into the lamp. In this case, a lamp lifetime may be shortened, because a distribution of a lamp enclosure substance inclines toward one side between low voltage terminal (Cold terminal) and high voltage terminal (Hot terminal). When designing the inverter, evaluate asymmetric of lamp working waveform sufficiently.

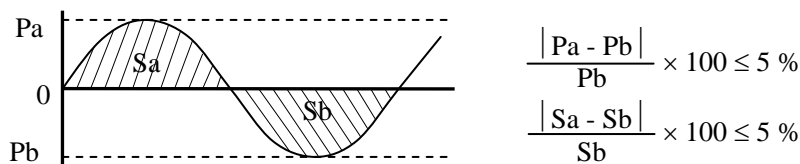

Pa: Supply voltage/current peak for positive, Pb: Supply voltage/current peak for negative
Sa: Waveform space for positive part, Sb: Waveform space for negative part.

Note4: The inverter should be designed so that the lamp starting voltage can be maintained for more than 1 second. Otherwise the lamp may not be turned on.

Note5: In case "FO" is not the recommended value, beat noise may display on the screen, because of interference between "FO" and "1/th". Recommended value of "FO" is as following

$$FO = \frac{1}{4} \times \frac{1}{th} \times (2n-1)$$

th: Horizontal cycle (See "4.9 INPUT SIGNAL TIMINGS".)

n: Natural number (1, 2, 3)

Note6: Method of lamp cable installation may invite fluctuation of lamp current and voltage or asymmetric of lamp working waveform. When designing method of lamp cable installation, evaluate the fluctuation of lamp current, voltage and working waveform sufficiently.

Note7: In case of Inverter with Ballast capacitor, "VS" is the voltage level between Ballast capacitor and Connector (Refer to the below "Example of measurement"). "VS" should be designed to be more than minimum "VS". Otherwise the lamp may not be turned on because the lamp starting voltage is less than minimum "VS".

Example of measurement

Probe capacitance: 3pF (Tektronix, Inc.: P6015A)

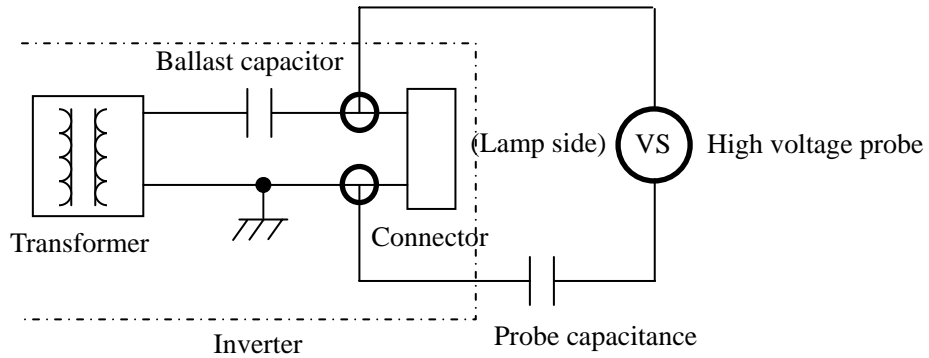

4.3.3 Power supply voltage ripple

This product works, even if the ripple voltage levels are beyond the permissible values as following the table, but there might be noise on the display image.

Power supply voltage		Ripple voltage (Measure at input terminal of power supply)	Note1	Unit
VCC	3.3V	≤ 100		mVp-p
	5.0V	≤ 100		mVp-p

Note1: The permissible ripple voltage includes spike noise.

4.3.4 Fuse

Parameter	Fuse		Rating	Fusing current	Remarks
	Type	Supplier			
VCC	ICP-S1.8	ROHM Co., Ltd.	1.8A	4.0A	Note1
			50V		

Note1: The power supply capacity should be more than the fusing current. If it is less than the fusing current, the fuse may not blow in a short time, and then nasty smell, smoke and so on may occur.

4.4 POWER SUPPLY VOLTAGE SEQUENCE

4.4.1 LCD panel signal processing board

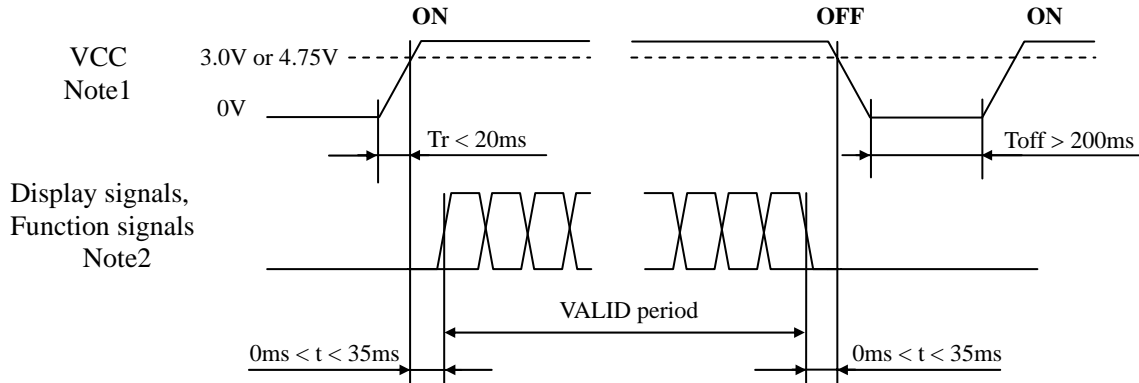

Note1: In terms of voltage variation (voltage drop) while VCC rising edge is below 3.0V in "VCC = 3.3V" or 4.75V in "VCC = 5.0V", a protection circuit may work, and then this product may not work.

Note2: Display signals (CLK, Hsync, Vsync, DE, DATA (R0 to R5, G0 to G5, B0 to B5)) and function signals (DPSH, DPSV, Q/V) must be Low or High-impedance, exclude the VALID period (See above sequence diagram), in order to avoid that internal circuits is damaged. If some of display and function signals of this product are cut while this product is working, even if the signal input to it once again, it might not work normally. VCC should be cut when the display and function signals are stopped.

4.4.2 Inverter (Option)

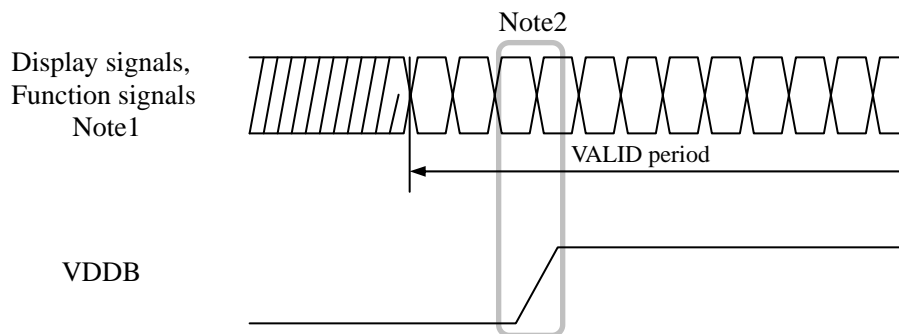

Note1: These are the display and function signals for LCD panel signal processing board.

Note2: The backlight should be turned on within the valid period of display and function signals, in order to avoid unstable data display.

4.5 CONNECTIONS AND FUNCTIONS FOR INTERFACE PINS

4.5.1 LCD panel signal processing board

CN1 socket (LCD module side): 08 6260 033 340 829+ (Kyocera Elco Corp.)

Pin No.	Symbol	Signal	Remarks	
1	GND	Ground	Note1	
2	CLK	Dot clock	-	
3	Hsync	Horizontal synchronous signal		
4	Vsync	Vertical synchronous signal		
5	GND	Ground	Note1	
6	R0	Red data (LSB)	Least significant bit	
7	R1	Red data	-	
8	R2	Red data		
9	R3	Red data		
10	R4	Red data		
11	R5	Red data (MSB)	Most significant bit	
12	GND	Ground	Note1	
13	G0	Green data (LSB)	Least significant bit	
14	G1	Green data	-	
15	G2	Green data		
16	G3	Green data		
17	G4	Green data		
18	G5	Green data (MSB)	Most significant bit	
19	GND	Ground	Note1	
20	B0	Blue data (LSB)	Least significant bit	
21	B1	Blue data	-	
22	B2	Blue data		
23	B3	Blue data		
24	B4	Blue data		
25	B5	Blue data (MSB)	Most significant bit	
26	GND	Ground	Note1	
27	DE	Selection of DE / Fixed mode	Data enable signal: DE mode High or Open: Fixed mode	
28	VCC	Power supply	Note1	
29	VCC	Power supply		
30	DPSH	Selection of scan direction (Horizontal)	Low or Open: Normal scan	Note2
31	DPSV	Selection of scan direction (Vertical)	High: Reverse scan	
32	Q/V	Selection of QVGA / VGA mode	High: VGA mode Low or Open: QVGA mode	Note2
33	GND	Ground	Note1	

Note1: All VCC and GND terminals should be used without any non-connected lines.

Note2: See "**4.8 SCANNING DIRECTIONS**".

4.5.2 Backlight lamp

Attention: VBLH and VBLC must be connected correctly. Wrong connections will cause electric shock and also break down of the product.

CN2 plug: BHR-03VS-1 (J.S.T Mfg. Co., Ltd.)
 Adaptable socket: SM03 (4.0) B-BHS-1-TB (LF) (SN),
 SM03 (4.0) B-BHS-1-TB (J.S.T. Mfg. Co., Ltd.)

Pin No.	Symbol	Signal	Remarks
1	VBLH	High voltage (Hot)	Cable color: Pink
2	N.C.	-	Keep this pin open.
3	VBLC	Low voltage (Cold)	Cable color: White

CN3 plug: BHR-03VS-1 (J.S.T Mfg. Co., Ltd.)
 Adaptable socket: SM03 (4.0) B-BHS-1-TB (LF) (SN),
 SM03 (4.0) B-BHS-1-TB (J.S.T. Mfg. Co., Ltd.)

Pin No.	Symbol	Signal	Remarks
1	VBLH	High voltage (Hot)	Cable color: Pink
2	N.C.	-	Keep this pin open.
3	VBLC	Low voltage (Cold)	Cable color: White

4.5.3 Positions of plugs and a socket

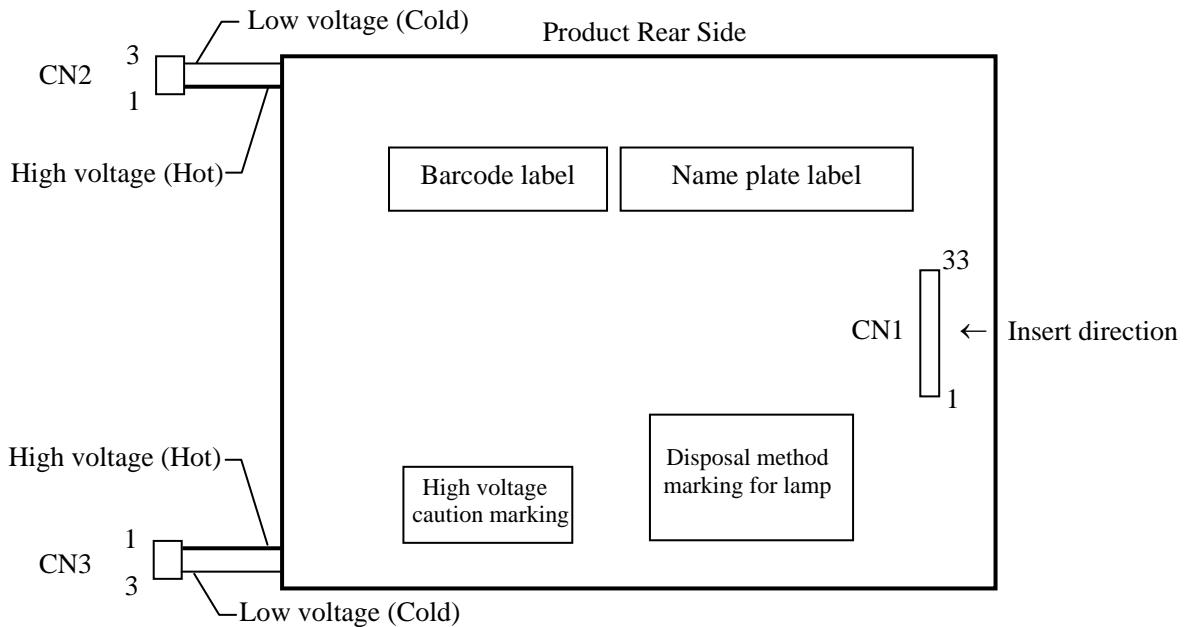

4.6 DISPLAY COLORS AND INPUT DATA SIGNALS

This product can display in equivalent to 262,144 colors in 64 gray scales. Also the relation between display colors and input data signals is as the following table.

Display colors		Data signal (0: Low level, 1: High level)																	
		R5	R4	R3	R2	R1	R0	G5	G4	G3	G2	G1	G0	B5	B4	B3	B2	B1	B0
Basic colors	Black	0	0	0	0	0	0	0	0	0	0	0	0	0	0	0	0	0	0
	Blue	0	0	0	0	0	0	0	0	0	0	0	0	1	1	1	1	1	1
	Red	1	1	1	1	1	1	0	0	0	0	0	0	0	0	0	0	0	0
	Magenta	1	1	1	1	1	1	0	0	0	0	0	0	1	1	1	1	1	1
	Green	0	0	0	0	0	0	1	1	1	1	1	1	0	0	0	0	0	0
	Cyan	0	0	0	0	0	0	1	1	1	1	1	1	1	1	1	1	1	1
	Yellow	1	1	1	1	1	1	1	1	1	1	1	1	0	0	0	0	0	0
	White	1	1	1	1	1	1	1	1	1	1	1	1	1	1	1	1	1	1
Red gray scale	Black	0	0	0	0	0	0	0	0	0	0	0	0	0	0	0	0	0	0
	dark	0	0	0	0	1	0	0	0	0	0	0	0	0	0	0	0	0	0
	↑				:					:						:			
	↓				:					:						:			
	bright	1	1	1	1	0	1	0	0	0	0	0	0	0	0	0	0	0	0
Red	1	1	1	1	1	1	0	0	0	0	0	0	0	0	0	0	0	0	
Green gray scale	Black	0	0	0	0	0	0	0	0	0	0	0	0	0	0	0	0	0	0
	dark	0	0	0	0	0	0	0	0	0	0	1	0	0	0	0	0	0	0
	↑				:					:						:			
	↓				:					:						:			
	bright	0	0	0	0	0	0	1	1	1	1	0	1	0	0	0	0	0	0
Green	0	0	0	0	0	0	1	1	1	1	1	1	0	0	0	0	0	0	
Blue gray scale	Black	0	0	0	0	0	0	0	0	0	0	0	0	0	0	0	0	0	0
	dark	0	0	0	0	0	0	0	0	0	0	0	0	0	0	0	0	1	0
	↑				:					:						:			
	↓				:					:						:			
	bright	0	0	0	0	0	0	0	0	0	0	0	0	1	1	1	1	0	1
Blue	0	0	0	0	0	0	0	0	0	0	0	0	1	1	1	1	1	0	
Blue	0	0	0	0	0	0	0	0	0	0	0	0	1	1	1	1	1	1	

4.7 DISPLAY POSITIONS

The following table is the coordinates per pixel (See "4.8 SCANNING DIRECTIONS".).

C (0, 0)									
<table border="1" style="margin: auto;"> <tr> <td style="padding: 2px;">R</td> <td style="padding: 2px;">G</td> <td style="padding: 2px;">B</td> </tr> </table>							R	G	B
R	G	B							
C(0, 0)	C(1, 0)	...	C(X, 0)	...	C(318, 0)	C(319, 0)			
C(0, 1)	C(1, 1)	...	C(X, 1)	...	C(318, 1)	C(319, 1)			
⋮	⋮	⋮	⋮	⋮	⋮	⋮			
C(0, Y)	C(1, Y)	...	C(X, Y)	...	C(318, Y)	C(319, Y)			
⋮	⋮	⋮	⋮	⋮	⋮	⋮			
C(0,238)	C(1,238)	...	C(X,238)	...	C(318, 238)	C(319, 238)			
C(0,239)	C(1,239)	...	C(X,239)	...	C(318, 239)	C(319, 239)			

4.8 SCANNING DIRECTIONS

4.8.1 QVGA mode

The following figures are seen from a front view. Also the arrow shows the direction of scan.

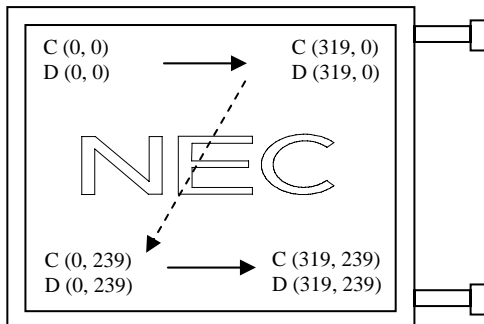

Figure1. DPSH= Low or Open (Normal scan)
DPSV= Low or Open (Normal scan)

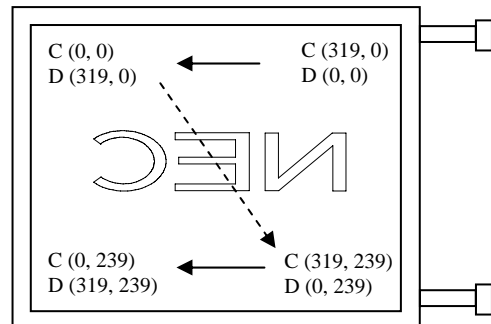

Figure2. DPSH= High (Reverse scan)
DPSV= Low or Open (Normal scan)

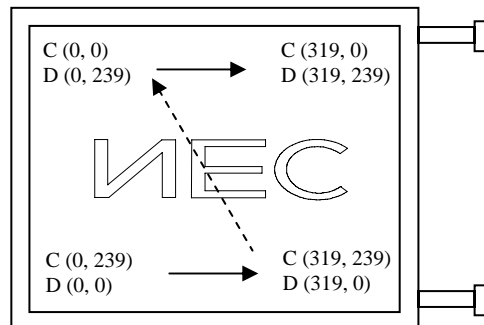

Figure3. DPSH= Low or Open (Normal scan)
DPSV= High (Reverse scan)

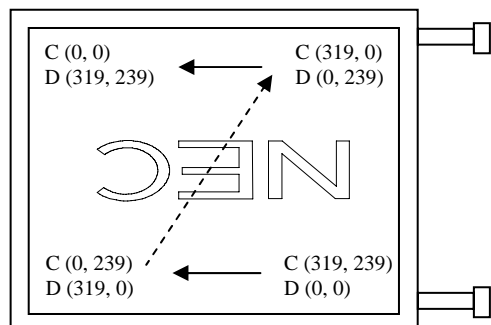

Figure4. DPSH= High (Reverse scan)
DPSV= High (Reverse scan)

Note1: Meaning of C (X, Y) and D (X, Y)

C (X, Y): The coordinates of the display position (See "4.7 DISPLAY POSITIONS".)

D (X, Y): The data number of input signal for LCD panel signal processing board

4.8.2 VGA mode

The following figures are seen from a front view. Also the arrow shows the direction of scan. In the VGA mode, only quarter of VGA data signals (640×480) are displayed on the screen.

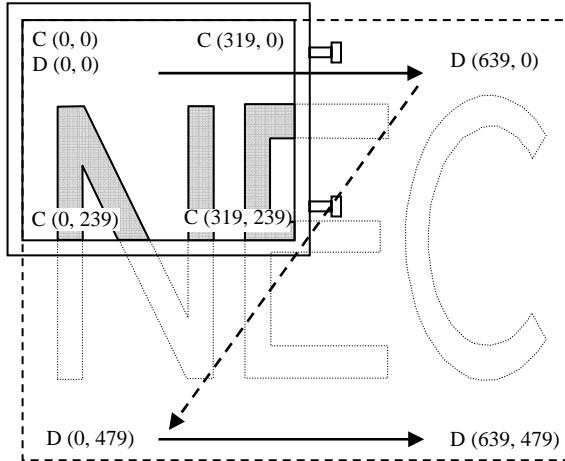

Figure1. DPSH= Low or Open (Normal scan)
DPSV= Low or Open (Normal scan)

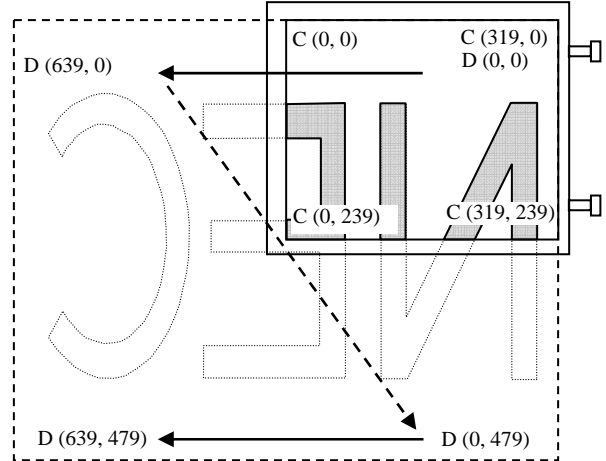

Figure2. DPSH= High (Reverse scan)
DPSV= Low or Open (Normal scan)

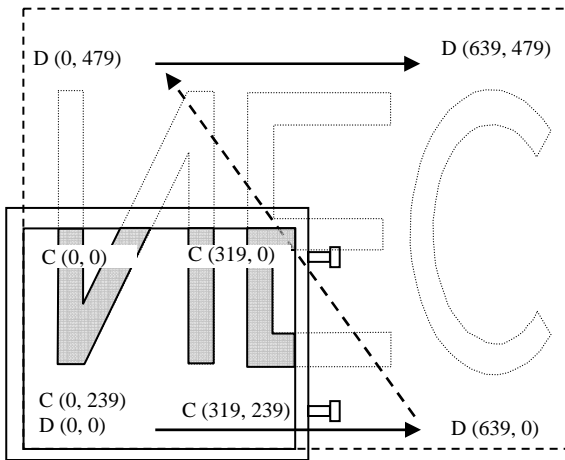

Figure3. DPSH= Low or Open (Normal scan)
DPSV= High (Reverse scan)

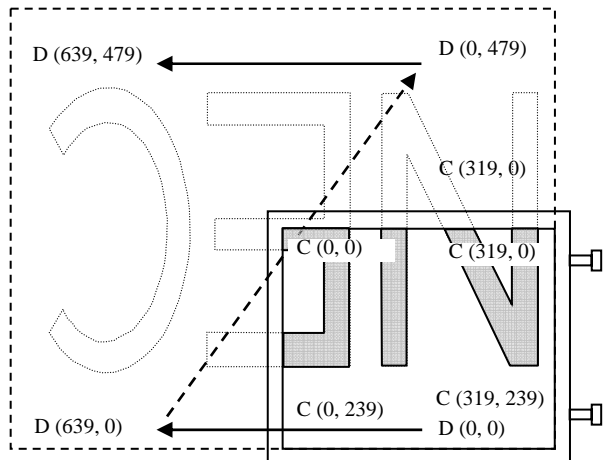

Figure4. DPSH= High (Reverse scan)
DPSV= High (Reverse scan)

Note1: Meaning of C (X, Y) and D (X, Y)

C (X, Y): The coordinates of the display position (See "4.7 DISPLAY POSITIONS".)

D (X, Y): The data number of input signal for LCD panel signal processing board

4.9 INPUT SIGNAL TIMINGS

4.9.1 QVGA mode

(1) Outline of input signal timings

• Horizontal signal

Note1

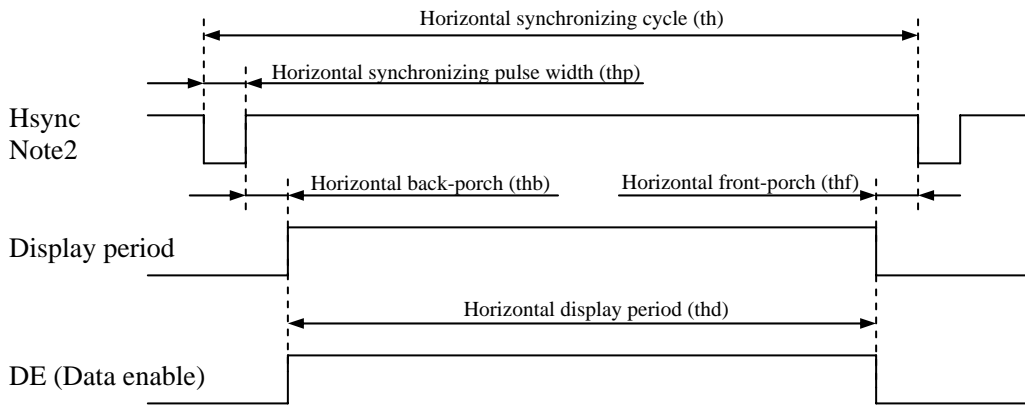

• Vertical signal

Note1

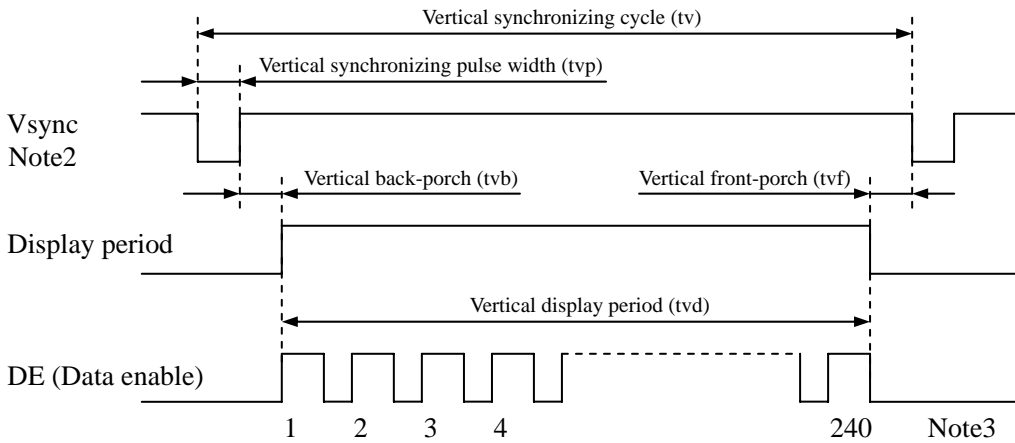

Note1: This diagram indicates virtual signal for set up to timing.

Note2: Fixed mode cannot be used while working of DE mode.

Note3: See "4.9.1 (3) Input signal timing chart" for numeration of pulse.

(2) Timing characteristics

(a) Fixed mode

(Note1)

Parameter		Symbol	min.	typ.	max.	Unit	Remarks		
CLK	Frequency	1/tc	5.0	6.4	7.0	MHz	157.5ns (typ.)		
	Duty	tcd	0.4	-	0.6	-	-		
	Rise time, Fall time	trf	-	-	10	ns	-		
DATA (R0-R5) (G0-G5) (B0-B5)	CLK-DATA	Setup time	tds	5	-	-	ns	-	
		Hold time	tdh	10	-	-	ns		
	Rise time, Fall time	tdrf	-	-	10	ns			
Hsync	Cycle	th	57.7	63.5	80.8	μs	15.7kHz (typ.)		
			404			CLK	-		
	Display period	thd	320			CLK			
	Front-porch	thf	7			CLK			
	Pulse width	thp	3	-	76	CLK			
	Back-porch	thb	1	-	74	CLK			
	Total of pulse width and back-porch	thp + thb	77			CLK		Note2	
	CLK-Hsync	Setup time	ths	5	-	-		ns	-
		Hold time	thh	10	-	-		ns	
Rise time, Fall time	thrf	-	-	10	ns				
Vsync	Cycle	tv	15.1	16.6	21.2	ms	60.1Hz (typ.)		
			262			H	-		
	Display period	tvd	240			H			
	Front-porch	tvf	1			H			
	Pulse width	tvp	2	-	20	H			
	Back-porch	tvb	1	-	19	H			
	Total of pulse width and back-porch	tvp + tvb	21			H		Note2	
	Hsync-Vsync timing	thv	1	-	-	CLK		-	
	Vsync-Hsync timing	tvh	10	-	-	ns			
Rise time, Fall time	tvrf	-	-	10	ns				

Note1: Definition of parameters is as follows.

tc= 1CLK, tcd= tch/tc, th= 1H

Note2: Keep tvp + tvb and thp + thb within the table. If it is out of specification, display position will be shifted to right/left side or up/down.

(b) DE mode

(Note1, Note2)

Parameter		Symbol	min.	typ.	max.	Unit	Remarks	
CLK	Frequency	1/tc	5.0	6.4	7.0	MHz	157.5ns (typ.)	
	Duty	tcd	0.4	-	0.6	-	-	
	Rise time, Fall time	tcrf	-	-	10	ns	-	
DATA (R0-R5) (G0-G5) (B0-B5)	CLK-DATA	Setup time	tds	5	-	-	ns	-
		Hold time	tdh	10	-	-	ns	
	Rise time, Fall time	tdrf	-	-	10	ns		
Vsync	Pulse width		tvp	2	-	20	H	-
	Vsync-DE	Setup time	tvds	1	-	-	CLK	
		Hold time	tvdh	1	-	-	CLK	
	Rise time, Fall time		tvrf	-	-	10	ns	
DE	Horizontal	Cycle	th	57.7	63.5	80.8	μs	15.7kHz (typ.)
				331	404	-	CLK	-
		Display period	thd	320			CLK	-
	Vertical (One frame)	Cycle	tv	15.1	16.6	21.2	ms	60.1Hz (typ.)
				242	262	-	H	-
		Display period	tvd	240			H	-
	CLK-DE	Setup time	tdes	5	-	-	ns	-
		Hold time	tdeh	10	-	-	ns	
	Rise time, Fall time		tderf	-	-	10	ns	-

Note1: Definition of parameters is as follows.

$$tc = 1CLK, tcd = tch/tc, th = 1H$$

Note2: Hsync signal (Pin No.3 of CN1) is not used inside the product at DE mode but do not keep pin open to avoid noise problem.

Note3: Vertical cycle (tv) should be specified in integral multiple of Horizontal cycle (th).



(3) Input signal timing chart

(a) Fixed mode

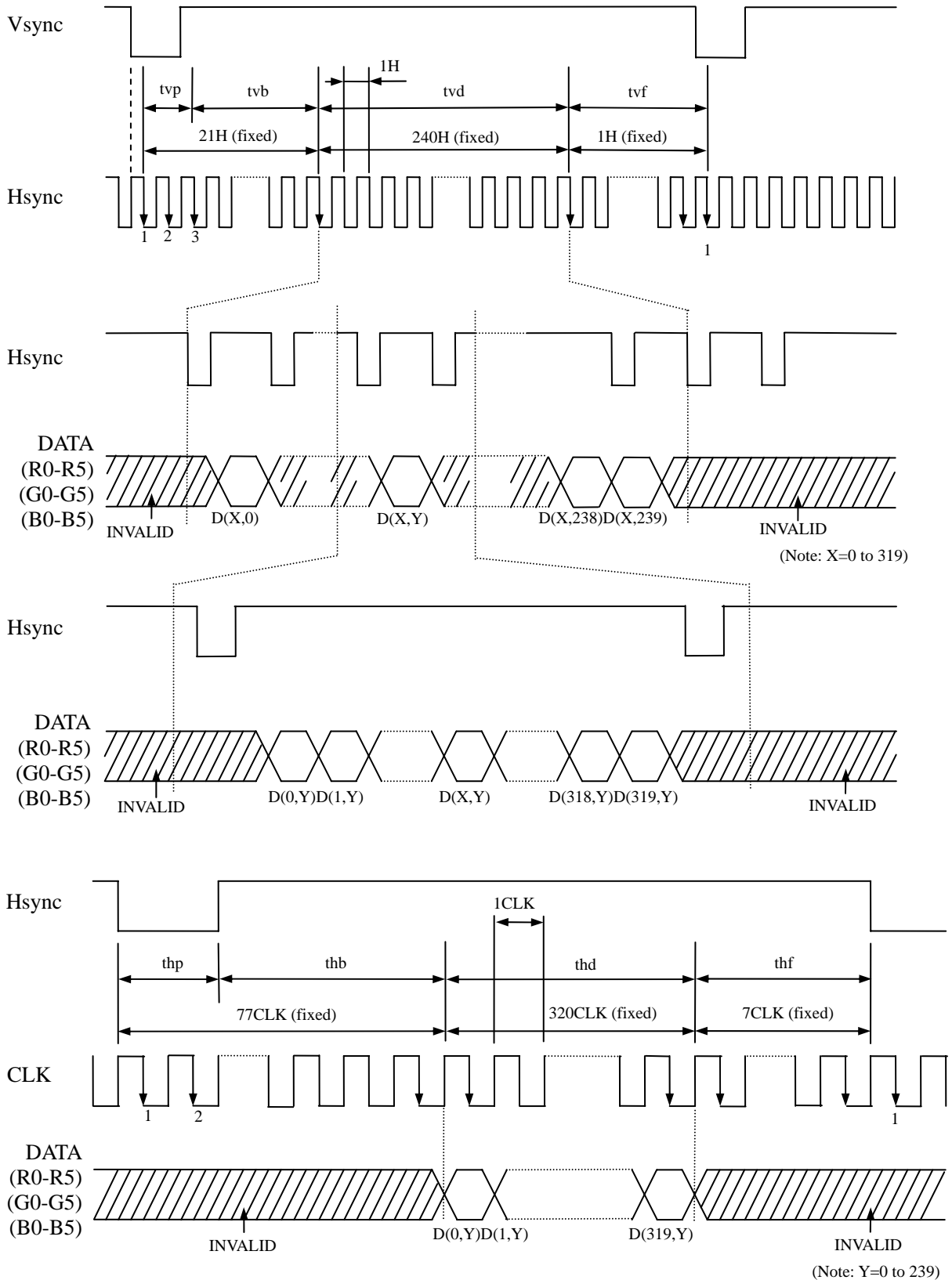

(b) DE mode

Horizontal timing

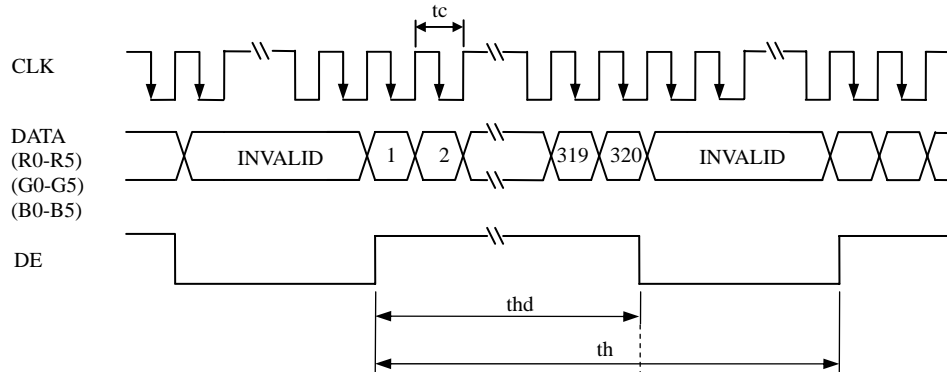

Vertical timing

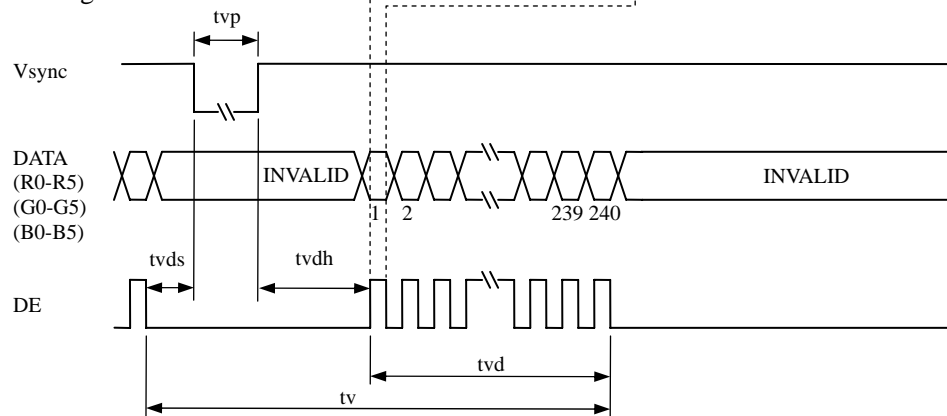

(c) Common item of Fixed mode and DE mode

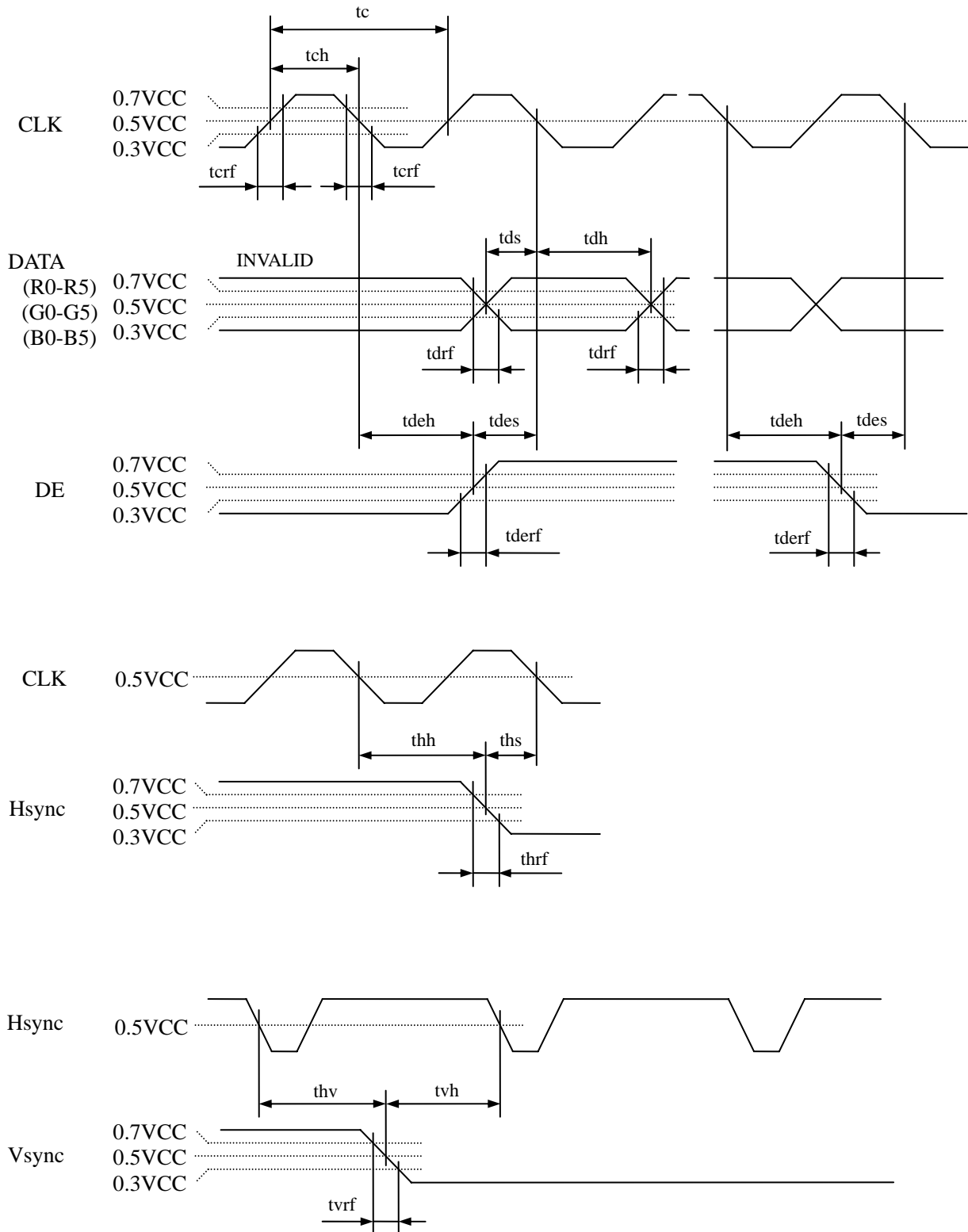

4.9.2 VGA mode

(1) Outline of input signal timings

• Horizontal signal

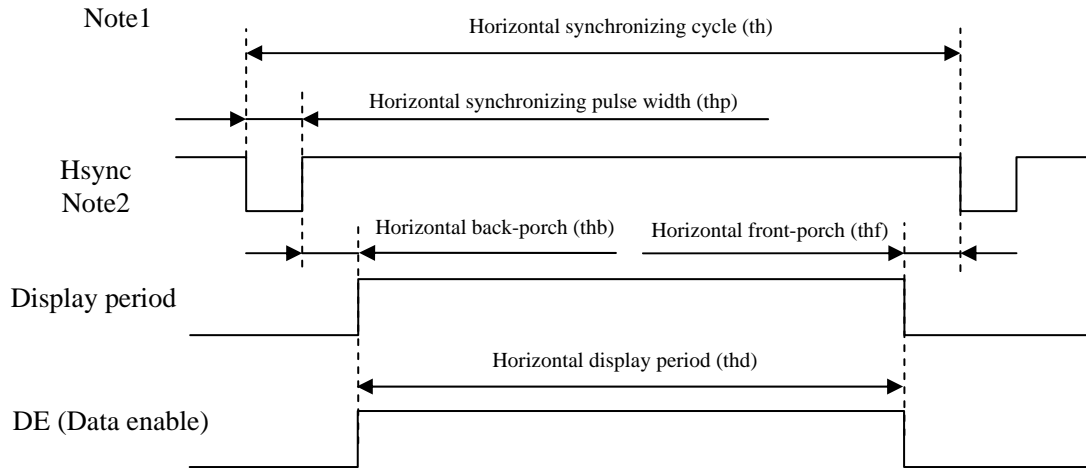

• Vertical signal

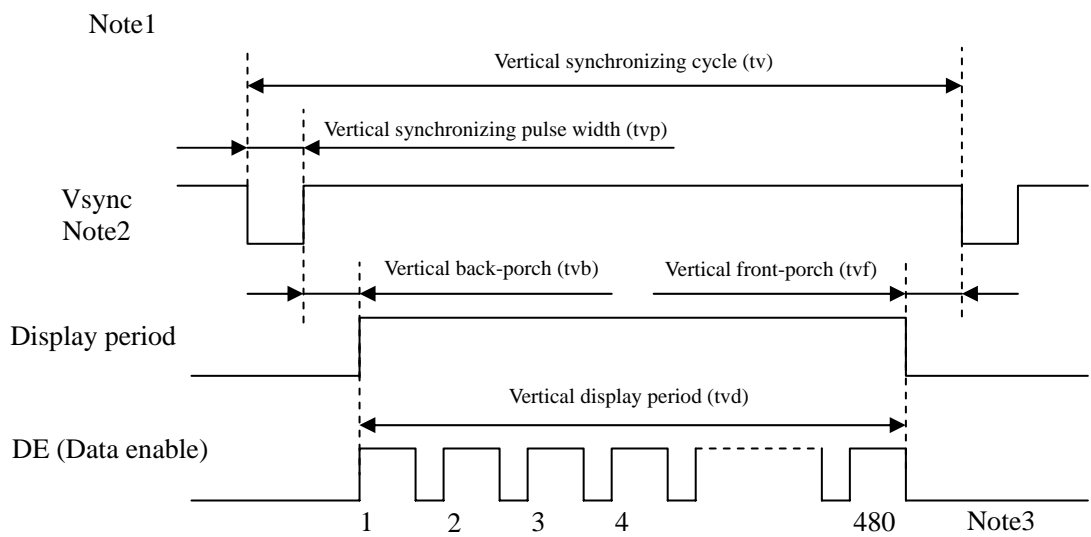

Note1: This diagram indicates virtual signal for set up to timing.

Note2: Fixed mode cannot be used while working of DE mode.

Note3: See "4.9.2 (3) Input signal timing chart" for numeration of pulse.

(2) Timing characteristics

(a) Fixed mode

(Note1)

Parameter		Symbol	min.	typ.	max.	Unit	Remarks		
CLK	Frequency	1/tc	21.0	25.175	29.0	MHz	39.72ns (typ.)		
	Duty	tcd	0.4	0.5	0.6	-	-		
	Rise time, Fall time	trf	-	-	10	ns	-		
DATA (R0-R5) (G0-G5) (B0-B5)	CLK-DATA	Setup time	tds	8	-	-	ns	-	
		Hold time	tdh	12	-	-	ns		
	Rise time, Fall time	trf	-	-	10	ns			
Hsync	Cycle	th	30.0	31.778	33.6	μs	31.468kHz (typ.)		
			800			CLK	-		
	Display period	thd	640			CLK			
	Front-porch	thf	16			CLK			
	Pulse width	thp	10	96	-	CLK			
	Back-porch	thb	-	48	134	CLK			
	Total of pulse width and back-porch	thp + thb	144			CLK		Note2	
	CLK- Hsync	Setup time	ths	8	-	-		ns	-
		Hold time	thh	12	-	-		ns	
Rise time, Fall time	thrf	-	-	10	ns				
Vsync	Cycle	tv	16.1	16.683	17.2	ms	59.94Hz (typ.)		
			525			H	-		
	Display period	tvd	480			H			
	Front-porch	tvf	12			H			
	Pulse width	tvp	1	2	-	H			
	Back-porch	tvb	-	31	32	H			
	Total of pulse width and back-porch	tvp + tvb	33			H		Note2	
	Hsync-Vsync timing	thv	1	-	-	CLK		-	
	Vsync-Hsync timing	tvh	30	-	-	ns			
Rise time, Fall time	tvrf	-	-	10	ns				

Note1: Definition of parameters is as follows.

tc= 1CLK, tcd= tch/tc, th= 1H

Note2: Keep tvp + tvb and thp + thb within the table. If it is out of specification, display position will be shifted to right/left side or up/down.

(b) DE mode

(Note1, Note2)

Parameter		Symbol	min.	typ.	max.	Unit	Remarks	
CLK	Frequency	1/tc	21.0	25.175	29.0	MHz	39.72ns (typ.)	
	Duty	tcd	0.4	0.5	0.6	-	-	
	Rise time, Fall time	tcrf	-	-	10	ns	-	
DATA (R0-R5) (G0-G5) (B0-B5)	CLK-DATA	Setup time	tds	8	-	-	ns	-
		Hold time	tdh	12	-	-	ns	
	Rise time, Fall time	tdrf	-	-	10	ns		
Vsync	Pulse width		tvp	1	2	-	H	-
	Vsync-DE timing	Setup time	tvds	1	-	-	CLK	
		Hold time	tvdh	1	-	-	CLK	
	Rise time, Fall time		tvrf	-	-	10	ns	
DE	Horizontal	Cycle	th	30.0	31.778	33.6	μs	31.468kHz (typ.)
				-	800	-	CLK	-
		Display period	thd	640			CLK	-
	Vertical (One frame)	Cycle	tv	16.1	16.683	17.2	ms	59.94Hz (typ.)
				-	525	-	H	-
		Display period	tvd	480			H	-
	CLK-DE	Setup time	tdes	8	-	-	ns	-
		Hold time	tdeh	12	-	-	ns	
Rise time, Fall time		tderf	-	-	10	ns		

Note1: Definition of parameters is as follows.

tc= 1CLK, tcd= tch/tc, th= 1H

Note2: Hsync signal (Pin No.3 of CN1) is not used inside the product at DE mode.

Do not keep pin open to avoid noise problem.

Note3: Vertical cycle (tv) should be specified in integral multiple of Horizontal cycle (th).



(3) Input signal timing chart

(a) Fixed mode

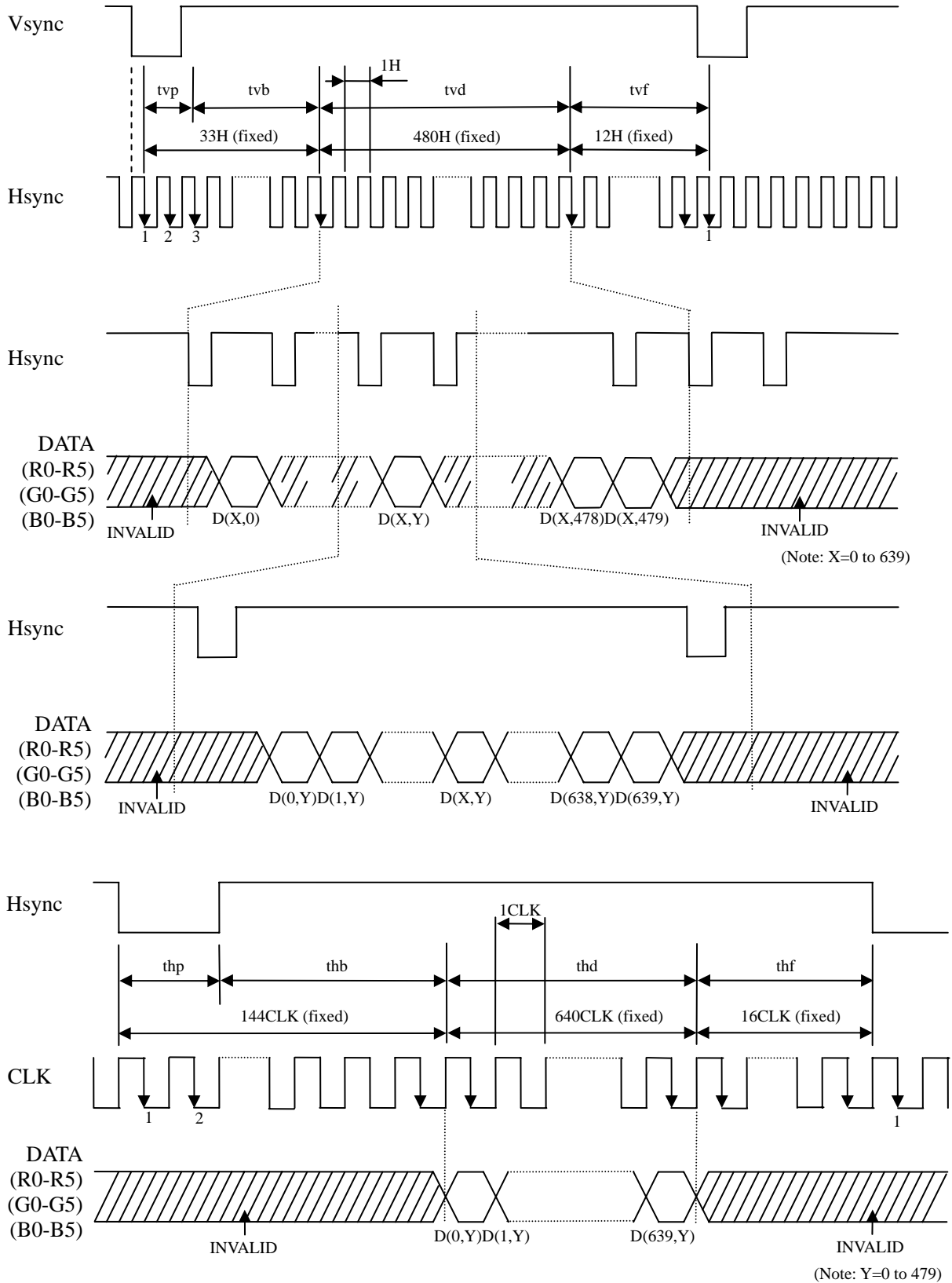

(b) DE mode

Horizontal timing

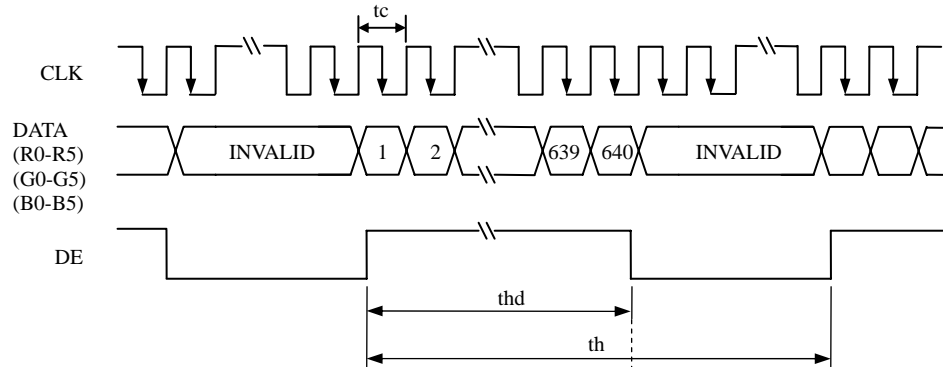

Vertical timing

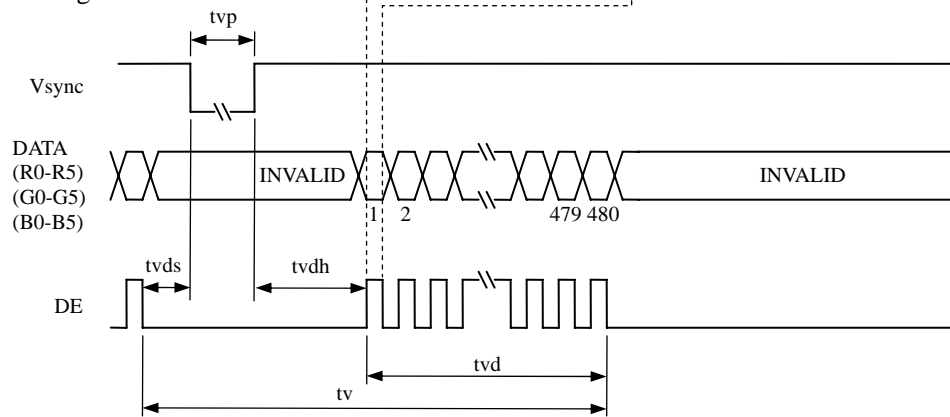

(c) Common item of Fixed mode and DE mode

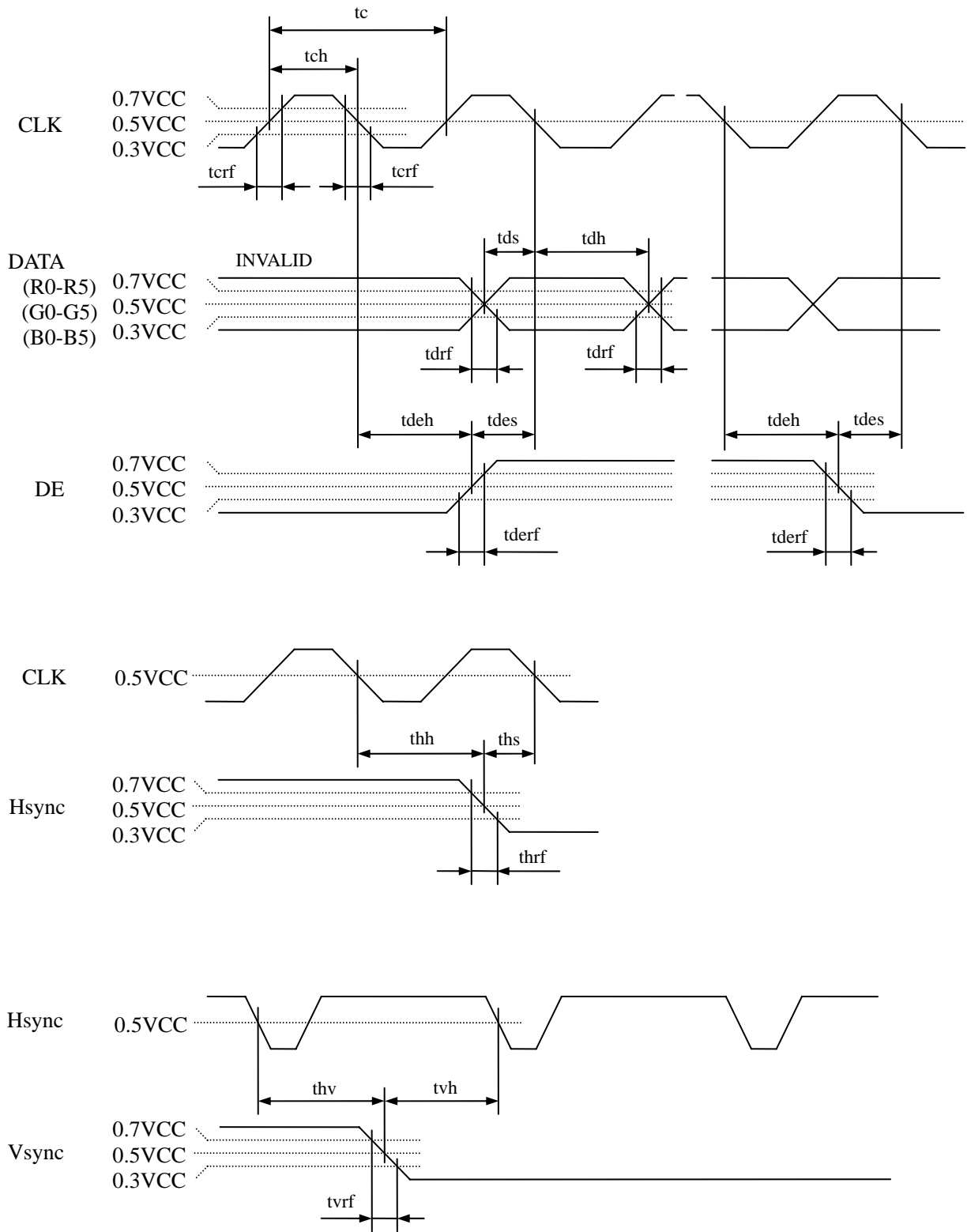

4.10 OPTICS

4.10.1 Optical characteristics

Optical characteristics are only applied to the QVGA mode. The VGA mode is exempted from the assurance.

(Note1, Note2)

Parameter	Condition	Symbol	min.	typ.	max.	Unit	Remarks	
Luminance	White at center $\theta R=0^\circ, \theta L=0^\circ, \theta U=0^\circ, \theta D=0^\circ$	L	550	750	-	cd/m ²	-	
Contrast ratio	White/Black at center $\theta R=0^\circ, \theta L=0^\circ, \theta U=0^\circ, \theta D=0^\circ$	CR	320	500	-	-	Note3	
Luminance uniformity	White $\theta R=0^\circ, \theta L=0^\circ, \theta U=0^\circ, \theta D=0^\circ$	LU	-	1.25	1.35	-	Note4	
Chromaticity	White	x coordinate	Wx	0.270	0.300	0.330	-	Note5
		y coordinate	Wy	0.310	0.340	0.370	-	
	Red	x coordinate	Rx	-	0.615	-	-	
		y coordinate	Ry	-	0.350	-	-	
	Green	x coordinate	Gx	-	0.320	-	-	
		y coordinate	Gy	-	0.575	-	-	
Blue	x coordinate	Bx	-	0.150	-	-		
	y coordinate	By	-	0.130	-	-		
Color gamut	$\theta R=0^\circ, \theta L=0^\circ, \theta U=0^\circ, \theta D=0^\circ$ at center, against NTSC color space	C	40	50	-	%		
Response time	White to Black	Ton	-	5	15	ms	Note6	
	Black to White	Toff	-	25	50	ms	Note7	
Viewing angle	Right	$\theta U=0^\circ, \theta D=0^\circ, CR \geq 10$	θR	45	55	-	°	Note8
	Left	$\theta U=0^\circ, \theta D=0^\circ, CR \geq 10$	θL	45	55	-	°	
	Up	$\theta R=0^\circ, \theta L=0^\circ, CR \geq 10$	θU	40	50	-	°	
	Down	$\theta R=0^\circ, \theta L=0^\circ, CR \geq 10$	θD	30	40	-	°	

Note1: These are initial characteristics.

Note2: Measurement conditions are as follows.

Ta= 25°C, VCC= 3.3V, IBL= 5.0mArms/lamp, QVGA, Horizontal cycle= 1/15.7kHz,
Vertical cycle= 1/60.1Hz, DPSH= Open, DPSV= Open, Q/V= Low or Open: QVGA mode

Optical characteristics are measured at luminance saturation after 20minutes from working the product, in the dark room. Also measurement methods are as follows.

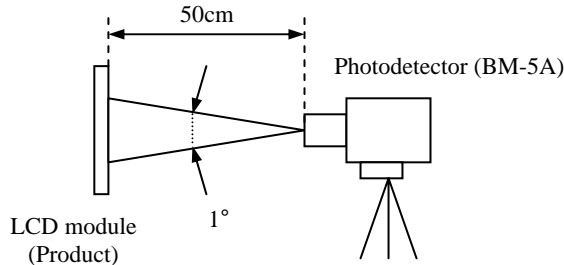

Note3: See "4.10.2 Definition of contrast ratio".

Note4: See "4.10.3 Definition of luminance uniformity".

Note5: These coordinates are found on CIE 1931 chromaticity diagram.

Note6: Product surface temperature: TopF= 33°C

Note7: See "4.10.4 Definition of response times".

Note8: See "4.10.5 Definition of viewing angles".

4.10.2 Definition of contrast ratio

The contrast ratio is calculated by using the following formula.

$$\text{Contrast ratio (CR)} = \frac{\text{Luminance of white screen}}{\text{Luminance of black screen}}$$

4.10.3 Definition of luminance uniformity

The luminance uniformity is calculated by using following formula.

$$\text{Luminance uniformity (LU)} = \frac{\text{Maximum luminance from ① to ⑤}}{\text{Minimum luminance from ① to ⑤}}$$

The luminance is measured at near the 5 points shown below.

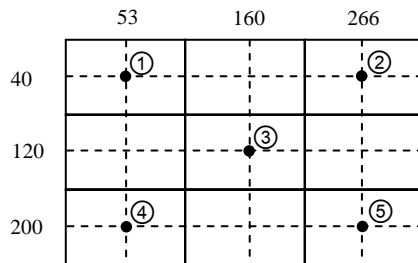

4.10.4 Definition of response times

Response time is measured, the luminance changes from "white" to "black", or "black" to "white" on the same screen point, by photo-detector. Ton is the time it takes the luminance change from 90% down to 10%. Also Toff is the time it takes the luminance change from 10% up to 90% (See the following diagram.).

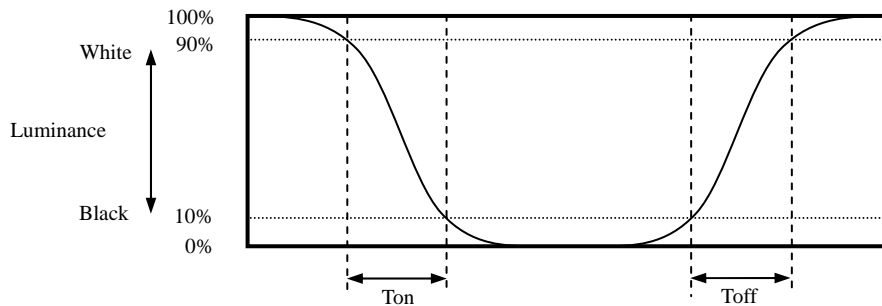

4.10.5 Definition of viewing angles

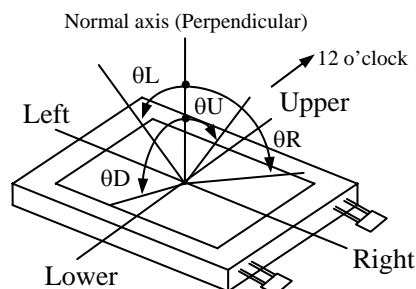



5. ESTIMATED LUMINANCE LIFETIME

The luminance lifetime is the time from initial luminance to half-luminance.

This lifetime is the estimated value, and is not guarantee value.

Condition		Luminance lifetime (MTTF) Note1, Note2	Unit
Module	25°C (Ambient temperature of the product) Continuous operation, IBL= 5.0mArms/lamp	36,000	h
	70°C (Surface temperature at screen center) Continuous operation, IBL= 5.0mArms/lamp	18,000	h
Cold cathode fluorescent lamp	25°C (Ambient temperature of the lamp) Continuous operation, IBL= 5.0mArms/lamp	40,000	h

Note1: MTTF is mean time to half-luminance.

Note2: In case the product works under low temperature environment, the lifetime becomes short.

6. RELIABILITY TESTS

Reliability tests are only applied to the QVGA mode. The VGA mode is exempted from the assurance.

Test item	Condition	Judgment	Note1
High temperature and humidity (Operation)	① 55 ± 2°C, RH = 85%, 240hours ② Display data is black.	No display malfunctions	
High temperature (Operation)	① 70 ± 3°C, 240hours ② Display data is black.		
Heat cycle (Operation)	① -10 ± 3°C...1hour 70 ± 3°C...1hour ② 50cycles, 4hours/cycle ③ Display data is black.		
Thermal shock (Non operation)	① -30 ± 3°C...30minutes 80 ± 3°C...30minutes ② 100cycles, 1hour/cycle ③ Temperature transition time is within 5 minutes.		
ESD (Operation)	① 150pF, 150Ω, ±10kV ② 9 places on a panel surface Note2 ③ 10 times each places at 1 sec interval		
Dust (Operation)	① Sample dust: No. 15 (by JIS-Z8901) ② 15 seconds stir ③ 8 times repeat at 1 hour interval		
Vibration (Non operation)	① 5 to 200Hz, 29.4m/s ² ② 10 minutes/cycle ③ X, Y directions...2hours ④ Z directions...4hours		
Mechanical shock (Non operation)	① 980m/ s ² , 11ms ② ±X, ±Y, ±Z directions ③ 3 times each directions		

Note1: Display and appearance are checked under environmental conditions equivalent to the inspection conditions of defect criteria.

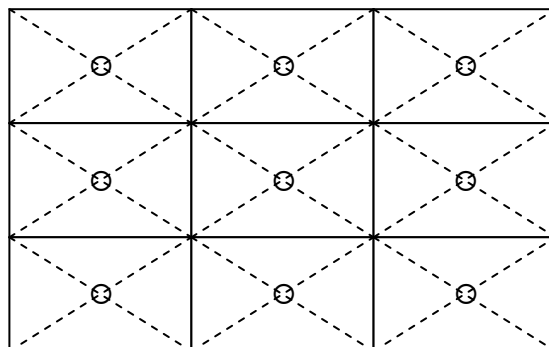

Note2: See the following figure for discharge points.





7. PRECAUTIONS

7.1 MEANING OF CAUTION SIGNS

The following caution signs have very important meaning. **Be sure to read "7.2 CAUTIONS" and "7.3 ATTENTIONS", after understanding these contents!**

	This sign has the meaning that customer will be injured by himself or the product will sustain a damage, if customer has wrong operations.
	This sign has the meaning that customer will get an electrical shock, if customer has wrong operations.
	This sign has the meaning that customer will be injured by himself, if customer has wrong operations.

7.2 CAUTIONS

	* Do not touch the working backlight. There is a danger of an electric shock.
	* Do not touch the working backlight. There is a danger of burn injury. * Do not shock and press the LCD panel and the backlight! There is a danger of breaking, because they are made of glass. (Shock: To be not greater 980m/s² and to be not greater 11ms, Pressure: To be not greater 19.6 N (φ16mm jig))

7.3 ATTENTIONS



7.3.1 Handling of the product

- ① Take hold of both ends without touching the circuit board when the product (LCD module) is picked up from inner packing box to avoid broken down or misadjustment, because of stress to mounting parts on the circuit board.
- ② Do not hook nor pull cables such as lamp cable, and so on, in order to avoid any damage.
- ③ When the product is put on the table temporarily, display surface must be placed downward.
- ④ When handling the product, take the measures of electrostatic discharge with such as earth band, ionic shower and so on, because the product may be damaged by electrostatic.
- ⑤ The torque for product mounting screws must never exceed 0.294N·m. Higher torque might result in distortion of the bezel.
- ⑥ The product must be installed using mounting holes without undue stress such as bends or twist (See outline drawings). And do not add undue stress to any portion (such as bezel flat area). Bends or twist described above and undue stress to any portion may cause display mura.
- ⑦ Do not press or rub on the sensitive product surface. When cleaning the product surface, wipe it with a soft dry cloth. ☆
- ⑧ Do not push nor pull the interface connectors while the product is working.

- ⑨ Do not bend or unbend the lamp cable at the near part of the lamp holding rubber, to avoid the damage for high voltage side of the lamp.
- ⑩ Properly connect the plug (backlight side) to adaptable socket (inverter side) without incomplete connection. After connecting, be careful not to hook the lamp cables because incomplete connection may occur by hooking the lamp cables. This incomplete connection may cause abnormal operation of high voltage circuit.
- ⑪ If the lamp cable is attached on the metal part of the product directly, high frequency leak current to the metal part may occur, then the brightness may decrease or the lamp may not be turned on.
- ⑫ When not connecting shield plate of the LCD module to the customer's equipment ground, inverter noise may create video noise on the LCD screen.
- ⑬ When handling the product, use of an original protection sheet on the product surface (polarizer) is recommended for protection of product surface. Adhesive type protection sheet may change color or characteristics of the polarizer.
- ⑭ Usually liquid crystals don't leak through the breakage of glasses because of the surface tension of thin layer and the construction of LCD panel. But, if you contact with liquid crystal for the worst, please wash it out with soap.

7.3.2 Environment

- ① Do not operate or store in high temperature, high humidity, dewdrop atmosphere or corrosive gases. Keep the product in packing box with antistatic pouch in room temperature to avoid dusts and sunlight, when storing the product.
- ② In order to prevent dew condensation occurring by temperature difference, the product packing box should be opened after enough time being left under the environment of an unpacking room. Evaluate the leaving time sufficiently because a situation of dew condensation occurring is changed by the environmental temperature and humidity. (Recommended leaving time: 6 hours or more with packing state)
- ③ Do not operate in high magnetic field. Circuit boards may be broken down by it.
- ④ This product is not designed as radiation hardened.

7.3.3 Characteristics

The following items are neither defects nor failures.

- ① Response time, luminance and color may be changed by ambient temperature.
- ② Display mura, flicker, vertical seam or small spot may be observed depending on display patterns.
- ③ Optical characteristics (e.g. luminance, display uniformity, etc.) gradually is going to change depending on operating time, and especially low temperature, because the LCD has cold cathode fluorescent lamps.
- ④ Do not display the fixed pattern for a long time because it may cause image sticking. Use a screen saver, if the fixed pattern is displayed on the screen.
- ⑤ The display color may be changed depending on viewing angle because of the use of condenser sheet in the backlight.
- ⑥ Optical characteristics may be changed depending on input signal timings.
- ⑦ The interference noise between input signal frequency for this product's signal processing board and luminance control frequency of the inverter may appear on a display. Set up luminance control frequency of the inverter so that the interference noise does not appear.
- ⑧ The color of the polarizer surface may differ between products because of antireflection treatment.
- ⑨ After the product is stored under condition of low temperature or dark place for a long time, the cold cathode fluorescent lamp may not be turned on under the same condition because of the general characteristic of cold cathode fluorescent lamp. In addition, when Luminance control ratio is low in pulse width modulation method inverter, the lamp may not be turned on. In this case, power should be supplied again.

7.3.4 Other

- ① All GND and VCC terminals should be used without any non-connected lines.
- ② Do not disassemble a product or adjust variable resistors.
- ③ See "REPLACEMENT MANUAL FOR LAMP HOLDER SET", when replacing backlight lamps.
- ④ Pack the product with original shipping package, in order to avoid any damages during transportation, when returning the product to NEC for repair and so on. ☆
- ⑤ The information of China RoHS directive six hazardous substances or elements in this product is as follows. ☆

China RoHS directive six hazardous substances or elements					
Lead (Pb)	Mercury (Hg)	Cadmium (Cd)	Hexavalent Chromium (Cr VI)	Polybrominated Biphenyls (PBB)	Polybrominated Biphenyl Ethers (PBDE)
×	×	○	○	○	○

Note1: ○: This indicates that the poisonous or harmful material in all the homogeneous materials for this part is equal or below the limitation level of SJ/T11363-2006 standard regulation.

×: This indicates that the poisonous or harmful material in all the homogeneous materials for this part is above the limitation level of SJ/T11363-2006 standard regulation.

8. OUTLINE DRAWINGS

8.1 FRONT VIEW

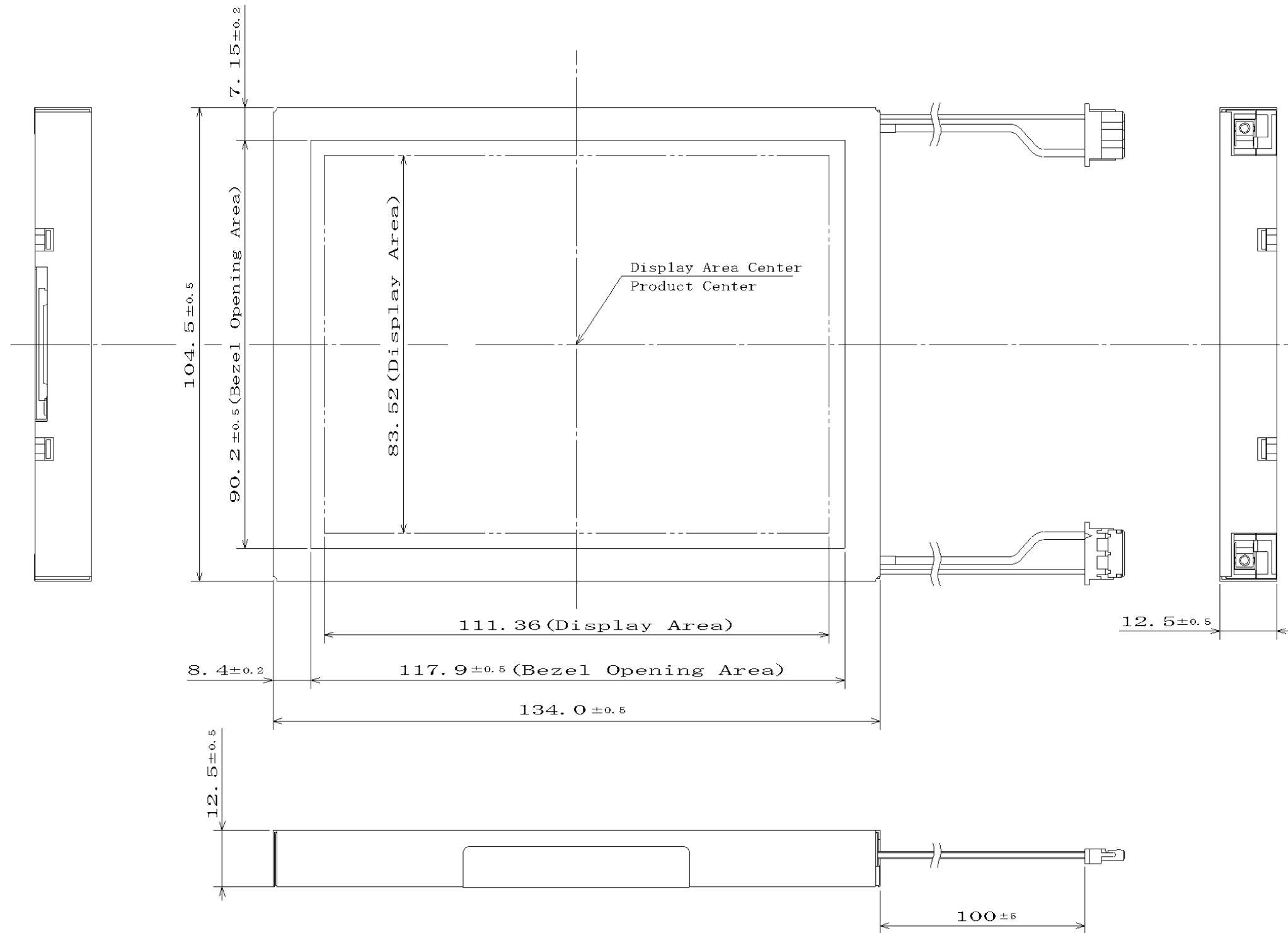

Note1: The torque for product mounting screws must never exceed 0.294N·m.

Unit: mm

8.2 REAR VIEW

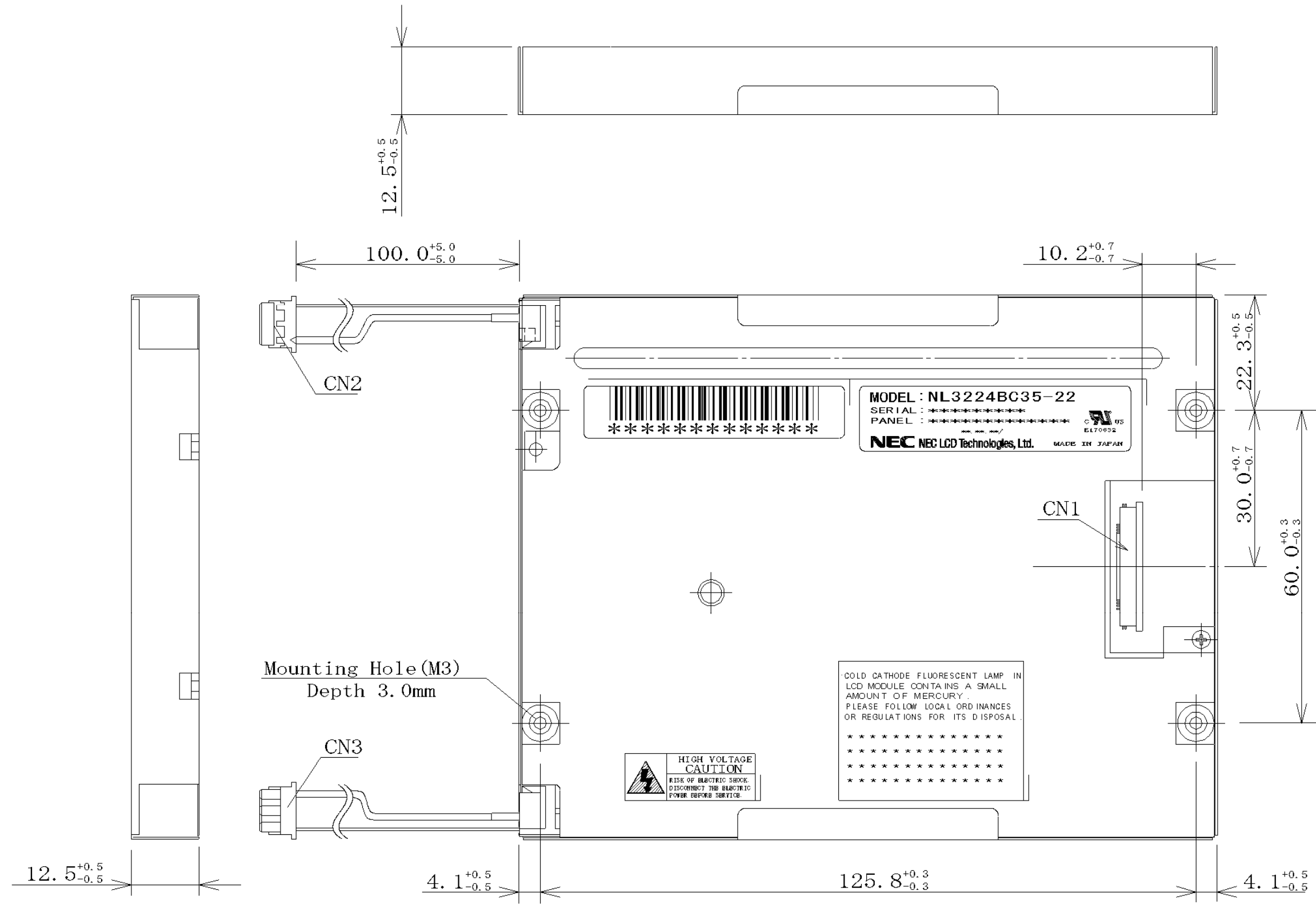

Unit: mm

Note1: The torque for product mounting screws must never exceed 0.294N-m.