

PRELIMINARY

NLT Technologies, Ltd.

TFT COLOR LCD MODULE

NL10276BC20-18KH

26cm (10.4 Type)

XGA

LVDS interface (1port)

PRELIMINARY DATA SHEET 

DOD-PP-1552 (1st edition)

**All information is subject to change without notice.
Please confirm the sales representative before
starting to design your system.**

PRELIMINARY

NLT Technologies, Ltd.

NL10276BC20-18KH

INTRODUCTION

The Copyright to this document belongs to NLT Technologies, Ltd. (hereinafter called "NLT"). No part of this document will be used, reproduced or copied without prior written consent of NLT.

NLT does and will not assume any liability for infringement of patents, copyrights or other intellectual property rights of any third party arising out of or in connection with application of the products described herein except for that directly attributable to mechanisms and workmanship thereof. No license, express or implied, is granted under any patent, copyright or other intellectual property right of NLT.

Some electronic products would fail or malfunction at a certain rate. In spite of every effort to enhance reliability of products by NLT, the possibility of failures and malfunction might not be avoided entirely. To prevent the risks of damage to death, human bodily injury or other property arising out thereof or in connection therewith, each customer is required to take sufficient measures in its safety designs and plans including, but not limited to, redundant system, fire-containment and anti-failure.

The products are classified into three grades: "**Standard**", "**Special**", and "**Specific**".

Each quality grade is designed for applications described below. Any customer who intends to use a product for application other than that of Standard is required to contact an NLT sales representative in advance.

The **Standard**: Applications as any failure, malfunction or error of the products are free from any damage to death, human bodily injury or other property (Products Safety Issue) and not related the safety of the public (Social Issues), like general electric devices.

Examples: Office equipment, audio and visual equipment, communication equipment, test and measurement equipment, personal electronic equipment, home electronic appliances, car navigation system (with no vehicle control functions), seat entertainment monitor for vehicles and airplanes, fish finder (except marine radar integrated type), PDA, etc.

The **Special**: Applications as any failure, malfunction or error of the products might directly cause any damage to death, human bodily injury or other property (Products Safety Issue) and the safety of the public (Social Issues) and required high level reliability by conventional wisdom.

Examples: Vehicle/train/ship control system, traffic signals system, traffic information control system, air traffic control system, surgery/operation equipment monitor, disaster/crime prevention system, etc.

The **Specific**: Applications as any failure, malfunction or error of the products might severe cause any damage to death, human bodily injury or other property (Products Safety Issue) and the safety of the public (Social Issues) and developed, designed and manufactured in accordance with the standards or quality assurance program designated by the customer who requires extremely high level reliability and quality.

Examples: Aerospace system (except seat entertainment monitor), nuclear control system, life support system, etc.

The quality grade of this product is the "**Standard**" unless otherwise specified in this document.

PRELIMINARY

CONTENTS

INTRODUCTION	2
1. OUTLINE	4
1.1 STRUCTURE AND PRINCIPLE	4
1.2 APPLICATION	4
1.3 FEATURES	4
2. GENERAL SPECIFICATIONS	5
3. BLOCK DIAGRAM	6
4. DETAILED SPECIFICATIONS	8
4.1 MECHANICAL SPECIFICATIONS	8
4.2 ABSOLUTE MAXIMUM RATINGS	8
4.3 ELECTRICAL CHARACTERISTICS	9
4.3.1 LCD panel signal processing board	9
4.3.2 Backlight lamp	10
4.3.3 Power supply voltage ripple	10
4.3.4 Fuse	10
4.4 Touch panel specification	10
4.5 POWER SUPPLY VOLTAGE SEQUENCE	11
4.5.1 LCD panel signal processing board	11
4.5.2 LED driver board	11
4.6 CONNECTIONS AND FUNCTIONS FOR INTERFACE PINS	12
4.6.1 LCD panel signal processing board	12
4.6.2 Backlight lamp	13
4.6.3 Touch panel	13
4.6.4 Positions of plug and socket	15
4.6.5 Connection between receiver and transmitter for LVDS	16
4.6.6 Input data mapping	19
4.7 DISPLAY COLORS AND INPUT DATA SIGNALS	20
4.7.1 Combinations of input data signals, FRC and MSL signals	20
4.7.2 16,777,216 colors	21
4.7.3 262,144 colors	22
4.8 DISPLAY POSITIONS	23
4.9 SCANNING DIRECTIONS	23
4.10 INPUT SIGNAL TIMINGS	24
4.10.1 Outline of input signal timings	24
4.10.2 Timing characteristics	25
4.10.3 Input signal timing chart	26
4.11 OPTICS	27
4.11.1 Optical characteristics	27
4.11.2 Definition of contrast ratio	28
4.11.3 Definition of luminance uniformity	28
4.11.4 Definition of response times	28
4.11.5 Definition of viewing angles	28
5. ESTIMATED LUMINANCE LIFETIME	29
6. RELIABILITY TESTS	30
7. PRECAUTIONS	31
7.1 MEANING OF CAUTION SIGNS	31
7.2 CAUTIONS	31
7.3 ATTENTIONS	31
7.3.1 Handling of the product	31
7.3.2 Environment	32
7.3.3 Characteristics	32
7.3.4 Others	32
8. OUTLINE DRAWINGS	33
8.1 FRONT VIEW	33
8.2 REAR VIEW	34
REVISION HISTORY	35

1. OUTLINE

1.1 STRUCTURE AND PRINCIPLE

Color LCD module NL10276BC20-18KH is composed of the amorphous silicon thin film transistor liquid crystal display (a-Si TFT LCD) panel structure with driver LSIs for driving the TFT (Thin Film Transistor) array, touch panel (T/P) and a backlight.

The a-Si TFT LCD panel structure is injected liquid crystal material into a narrow gap between the TFT array glass substrate and a color-filter glass substrate.

Color (Red, Green, Blue) data signals from a host system (e.g. signal generator, etc.) are modulated into best form for active matrix system by a signal processing board, and sent to the driver LSIs which drive the individual TFT arrays.

The TFT array as an electro-optical switch regulates the amount of transmitted light from the backlight assembly, when it is controlled by data signals. Color images are created by regulating the amount of transmitted light through the TFT array of red, green and blue dots.

1.2 APPLICATION

- For industrial use

1.3 FEATURES

- Projected capacitive touch panel (P-CAP T/P) attached
- Long life LED backlight type
- Optical bonding
- High contrast
- Wide temperature range
- LVDS interface
- Reversible-scan direction
- Selectable 8bit or 6bit digital signals for data of RGB
- Replaceable lamp for backlight

PRELIMINARY

NLT Technologies, Ltd.

NL10276BC20-18KH

2. GENERAL SPECIFICATIONS

Display area	210.432 (H) × 157.824 (V) mm															
Diagonal size of display	26cm (10.4 inches)															
Drive system	a-Si TFT active matrix															
Display color	16,777,216 colors (At 8-bit input, FRC terminal= High) 262,144 colors (At 6-bit input, FRC terminal= Low or Open)															
Pixel	1,024 (H) × 768 (V) pixels															
Pixel arrangement	RGB (Red dot, Green dot, Blue dot) vertical stripe															
Dot pitch	0.0685 (H) × 0.2055 (V) mm															
Pixel pitch	0.2055 (H) × 0.2055 (V) mm															
Module size	228.0 (W) × 178.5 (H) × (10.55) (D) mm (typ.)															
Weight	TBD g (typ.)															
Contrast ratio	TBD: 1 (typ.)															
Viewing angle	At the contrast ratio $\geq 10:1$ <ul style="list-style-type: none"> • Horizontal: Right side (80)° (typ.), Left side (80)° (typ.) • Vertical: Up side (80)° (typ.), Down side (80)° (typ.) 															
Designed viewing direction	At DPS= Low or Open: Normal scan <ul style="list-style-type: none"> • Viewing direction without image reversal: Up side (12 o'clock) • Viewing direction with contrast peak: Down side (6 o'clock) • Viewing angle with optimum grayscale ($\gamma \approx 2.2$): Normal axis (perpendicular) 															
Touch panel type	Projected capacitive <table border="0" style="width: 100%; border-collapse: collapse;"> <tr> <td style="border: none;">(</td> <td style="border: none; padding: 0 10px;">Recommended Touch panel controller board (Option)</td> <td style="border: none;">)</td> </tr> <tr> <td style="border: none;"></td> <td style="border: none; padding: 0 10px;">• Touch panel controller board: Type No. PTPW01</td> <td style="border: none;"></td> </tr> </table>	(Recommended Touch panel controller board (Option))		• Touch panel controller board: Type No. PTPW01										
(Recommended Touch panel controller board (Option))														
	• Touch panel controller board: Type No. PTPW01															
Touch panel surface	Antiglare															
Touch panel pencil-hardness	(2)H (min.) [by JIS K5600]															
Touch panel cover glass	0.7mm normal glass															
Touch panel bonding method	Optical bonding															
Color gamut	At LCD panel center 40 % (typ.) [against NTSC color space]															
Response time	Ton+Toff (10%←→90%) 18 ms (typ.)															
Luminance	At IL= 60mA/ One circuit (780) cd/m ² (typ.)															
Signal system	LVDS 1port (Receiver: THC63LVDF84B, Thine Electronics Inc. or equivalent) 8bit/6bit digital signals for data of RGB colors, Dot clock (CLK), Data enable (DE)															
Power supply voltage	LCD panel signal processing board: 3.3V															
Backlight	LED backlight type: <table border="0" style="width: 100%; border-collapse: collapse;"> <tr> <td style="border: none;">(</td> <td style="border: none; padding: 0 10px;">Replaceable part</td> <td style="border: none;">)</td> </tr> <tr> <td style="border: none;"></td> <td style="border: none; padding: 0 10px;">• Lamp holder set: Type No. 104LHS55</td> <td style="border: none;"></td> </tr> <tr> <td style="border: none;">(</td> <td style="border: none; padding: 0 10px;">Recommended LED driver board (Option)</td> <td style="border: none;">)</td> </tr> <tr> <td style="border: none;"></td> <td style="border: none; padding: 0 10px;">• LED driver board: Type No. 104PW02F</td> <td style="border: none;"></td> </tr> <tr> <td style="border: none;"></td> <td style="border: none; padding: 0 10px;">• Corresponding wiring harness: Type No. 104CBL01</td> <td style="border: none;"></td> </tr> </table>	(Replaceable part)		• Lamp holder set: Type No. 104LHS55		(Recommended LED driver board (Option))		• LED driver board: Type No. 104PW02F			• Corresponding wiring harness: Type No. 104CBL01	
(Replaceable part)														
	• Lamp holder set: Type No. 104LHS55															
(Recommended LED driver board (Option))														
	• LED driver board: Type No. 104PW02F															
	• Corresponding wiring harness: Type No. 104CBL01															
Power consumption	At IL= 60mA/ One circuit, Checkered flag pattern 4.8 W (typ.) (except for T/P)															

3. BLOCK DIAGRAM

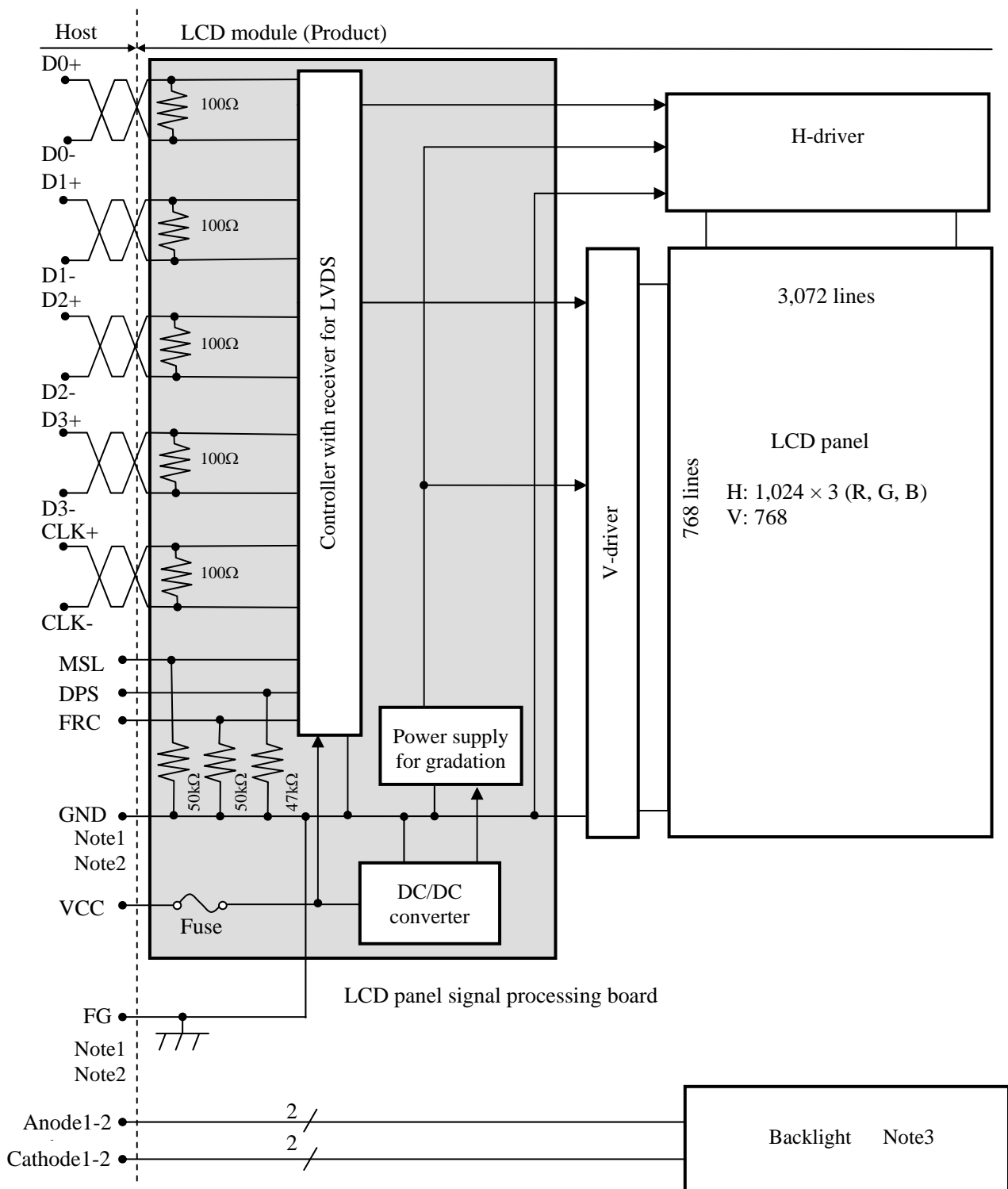

Note1: Relations between GND (Signal ground), FG (Frame ground) in the LCD module are as follows.

GND- FG	Connected
---------	-----------

Note2: GND and FG must be connected to customer equipment's ground, and it is recommended that these grounds be connected together in customer equipment.

PRELIMINARY

NLT Technologies, Ltd.

NL10276BC20-18KH

Note3: Backlight in detail

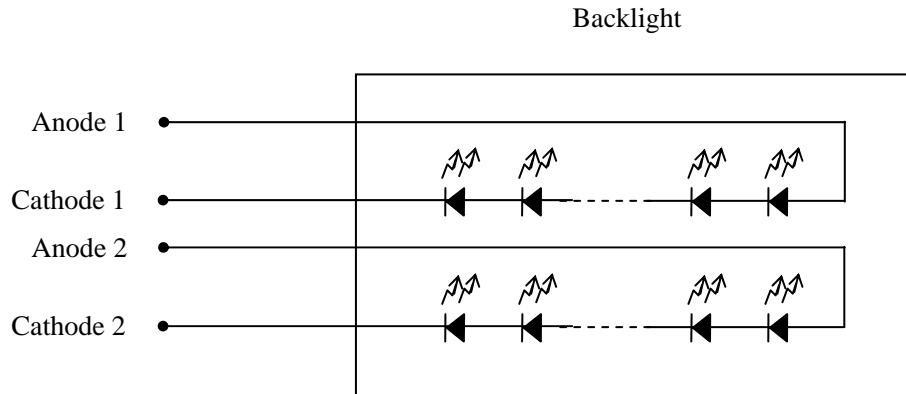

PRELIMINARY

NLT Technologies, Ltd.

NL10276BC20-18KH

4. DETAILED SPECIFICATIONS

4.1 MECHANICAL SPECIFICATIONS

Parameter	Specification	Unit
Module size	228.0 ± 0.5 (W) × 178.5 ± 0.5 (H) × (10.55) (D) Note1	mm
Display area	210.432 (H) × 157.824 (V) Note1	mm
Weight	TBD (typ.), TBD (max.)	g

Note1: See "8. OUTLINE DRAWINGS".

4.2 ABSOLUTE MAXIMUM RATINGS

Parameter		Symbol	Rating	Unit	Remarks
Power supply voltage	LCD panel signal processing board	VCC	-0.3 to +4.0	V	-
Input voltage for signals	Display signals Note1	VD	-0.3 to VCC+0.3	V	
	Function signals Note2	VF			
Backlight	Forward current	IL	0 to +70	mA	per one circuit
Touch panel input voltage		Vtp	6.0	V	-
Storage temperature		Tst	-30 to +80	°C	-
Operating temperature	Front surface	TopF	-30 to +(80)	°C	Note3
	Rear surface	TopR	-30 to +(80)	°C	Note4
Relative humidity Note5		RH	≤ 95	%	Ta ≤ 40°C
			≤ 85	%	40°C < Ta ≤ 50°C
			≤ 55	%	50°C < Ta ≤ 60°C
			≤ 36	%	60°C < Ta ≤ 70°C
			≤ 24	%	70°C < Ta ≤ 80°C
Absolute humidity Note5		AH	≤ 70 Note6	g/m ³	-

Note1: D0+/-, D1+/-, D2+/-, D3+/-, CLK+/-

Note2: DPS, FRC, MSL

Note3: Measured at Touch panel surface (including self-heat)

Note4: Measured at LCD module's rear shield surface (including self-heat)

Note5: No condensation

Note6: Water amount at Ta= 80°C and RH= 24%

PRELIMINARY

NLT Technologies, Ltd.

NL10276BC20-18KH

4.3 ELECTRICAL CHARACTERISTICS

4.3.1 LCD panel signal processing board

(Ta= 25°C)

Parameter	Symbol	min.	typ.	max.	Unit	Remarks	
Power supply voltage	VCC	3.0	3.3	3.6	V	-	
Power supply current	ICC	-	450 Note1	780 Note2	mA	at VCC= 3.3V	
Permissible ripple voltage	VRP	-	-	100	mVp-p	for VCC	
Differential input threshold voltage	High	VTH	-	-	+100	mV	at VCM= 1.2V Note3
	Low	VTL	-100	-	-	mV	
Terminating resistance	RT	-	100	-	Ω	-	
Input voltage for DPS, FRC and MSL signals	High	VFH	0.7VCC	-	VCC	V	CMOS level
	Low	VFL	0	-	0.3VCC	V	
Input current for DPS, FRC and MSL signals	High	IFH	-	-	300	μA	-
	Low	IFL	-300	-	-	μA	

Note1: Checkered flag pattern [by EIAJ ED-2522]

Note2: Pattern for maximum current

Note3: Common mode voltage for LVDS receiver

PRELIMINARY

4.3.2 Backlight lamp

(Note1, Note2, Note3)

Parameter	Symbol	min.	typ.	max.	Unit	Remarks
Forward current	IL	-	60	66	mA	-
Forward voltage	VL	24.3	27.8	31.4	V	Ta= +25°C at IL= 60mA/One circuit
		21.8	-	-		Ta= +80°C at IL= 60mA/One circuit
		-	-	34.4		Ta= -30°C at IL= 60mA/One circuit
		-	-	34.8		Ta= -30°C at IL= 66mA/One circuit

Note1: Please drive with constant current.

Note2: The above specifications are for one LED circuit of the backlight.

Note3: The Luminance uniformity may be changed depending on the current variation between 2 circuits. It is recommended that the current value difference among the circuits be less than 5%.

4.3.3 Power supply voltage ripple

This product works if the ripple voltage levels are over the permissible values as the following table, but there might be noise on the display image.

Power supply voltage	Ripple voltage (Measure at input terminal of power supply)	Note1	Unit
VCC	3.3V	≤ 100	mVp-p

Note1: The permissible ripple voltage includes spike noise.

4.3.4 Fuse

Parameter	Fuse		Rating	Fusing current	Remarks
	Type	Supplier			
VCC	FCC16202AB	KAMAYA ELECTRIC Co., Ltd.	2.0 A	4.0 A	Note1
			36 V		

Note1: The power supply's rated current must be more than the fusing current. If it is less than the fusing current, the fuse may not blow in a short time, and then nasty smell, smoke and so on may occur.

4.4 Touch panel specification

(Ta= 25°C)

Parameter	Symbol	min.	typ.	max.	Unit	Remarks	
X drive voltage	XVDD	2.5	3.3	10.5	V	-	
Accuracy	Center	Acrc	-	-	(1.5)	mm	Note1
	Boarder	Acrb	-	-	(2.5)	mm	Note1
Number of touch	NUM	1	-	16	Point	Note2	
Resolution	X	-	-	-	4,096	-	Note2
	Y	-	-	-	4,096	-	Note2

Note1: Input method is φ8mm conductive stylus

Note2: Using the Touch panel controller board, which is a option parts.

Note3: See "8. OUTLINE DRAWINGS".

4.5 POWER SUPPLY VOLTAGE SEQUENCE

4.5.1 LCD panel signal processing board

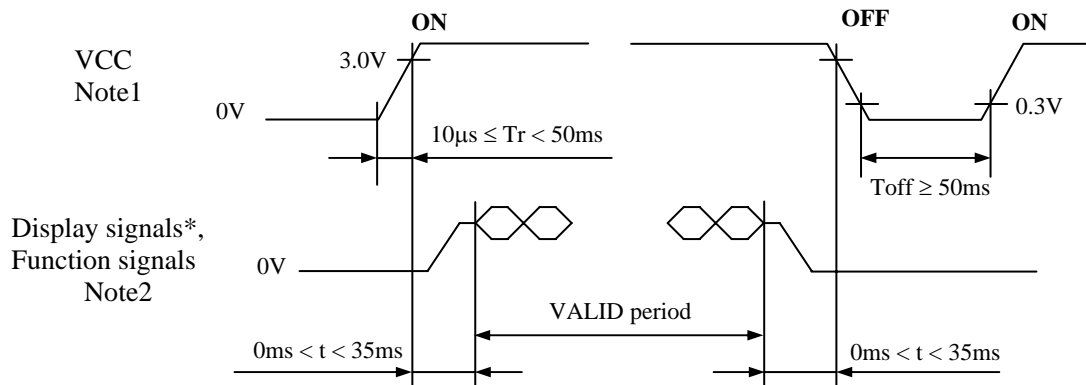

* These signals should be measured at the terminal of 100Ω resistance.

Note1: If there is a voltage variation (voltage drop) at the rising edge of VCC below 3.0V, there is a possibility that a product does not work due to a protection circuit.

Note2: Display signals (D0+/-, D1+/-, D2+/-, D3+/- and CLK+/-) and function signals (DPS, FRC and MSL) must be set to Low or High-impedance, except the VALID period (See above sequence diagram), in order to avoid the circuitry damage.

If some of display and function signals of this product are cut while this product is working, even if the signal input to it once again, it might not work normally. If a customer stops the display and function signals, VCC also must be shut down.

4.5.2 LED driver board

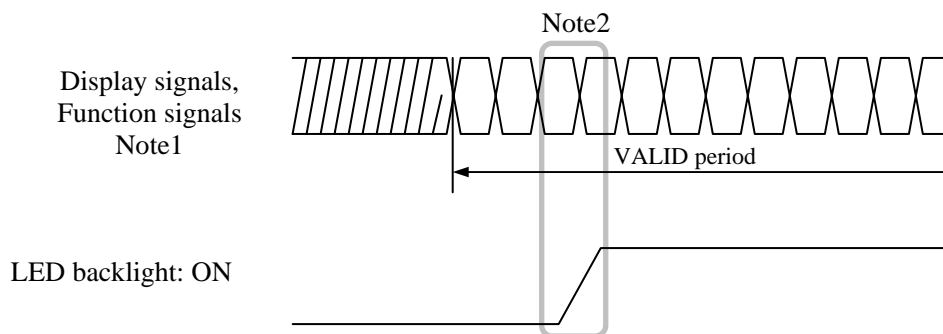

Note1: These are the display and function signals for LCD panel signal processing board.

Note2: The backlight should be turned on within the valid period of display and function signals, in order to avoid unstable data display.

PRELIMINARY

4.6 CONNECTIONS AND FUNCTIONS FOR INTERFACE PINS

4.6.1 LCD panel signal processing board

CN1 socket (LCD module side): FI-SE20P-HFE (Japan Aviation Electronics Industry Limited (JAE))
 Adaptable plug: FI-S20S (Japan Aviation Electronics Industry Limited (JAE))

Pin No.	Symbol	Signal	Input data signal: 8bit		Input data signal: 6bit	Remarks	
			MAP A	MAP B			
1	A	D3+	Pixel data	R0-R1,G0-G1,B0-B1	R6-R7,G6-G7,B6-B7	-	Note1, Note2
	B	GND	Ground	-		Ground	Note3
2	A	D3-	Pixel data	R0-R1,G0-G1,B0-B1	R6-R7,G6-G7,B6-B7	-	Note1, Note2
	B	GND	Ground	-		Ground	Note3
3	DPS	Selection of scan direction	High : Reverse scan Low or Open : Normal scan				Note4
4	FRC	Selection of the number of colors	High		Low or Open		Note1 Note5
5	GND	Ground	Ground				Note3
6	CLK+	Pixel clock	Pixel clock				Note2
7	CLK-						
8	GND	Ground	Ground				Note3
9	D2+	Pixel data	B4-B7,DE	B2-B5,DE			Note2
10	D2-						
11	GND	Ground	Ground				Note3
12	D1+	Pixel data	G3-G7,B2-B3	G1-G5,B0-B1			Note2
13	D1-						
14	GND	Ground	Ground				Note3
15	D0+	Pixel data	R2-R7,G2	R0-R5,G0			Note2
16	D0-						
17	GND	Ground	Ground				Note3
18	MSL	Selection of LVDS input map	Low	High	Low		Note5
19	VCC	Power supply	Power supply				Note3
20	VCC						

Note1: See "**4.7 DISPLAY COLORS AND INPUT DATA SIGNALS**".

Note2: Twist pair wires with 100Ω (Characteristic impedance) should be used between LCD panel signal processing board and LVDS transmitter.

Note3: All GND and VCC terminals should be used without any non-connected lines.

Note4: See "**4.9 SCANNING DIRECTIONS**".

Note5: See "**4.6.5 Connection between receiver and transmitter for LVDS**".

PRELIMINARY

NLT Technologies, Ltd.

NL10276BC20-18KH

4.6.2 Backlight lamp

CN2 plug (LCD module side): SM8B-SRSS-TB (J.S.T. Mfg. Co., Ltd.)

Adaptable socket: SHR-08V-S, SHR-08V-S-B (J.S.T. Mfg. Co., Ltd.)

Pin No.	Symbol	Signal	Remarks
1	A1	Anode1	-
2	K1	Cathode1	-
3	A2	Anode2	-
4	K2	Cathode2	-
5	N. C.	-	Keep this pin Open.
6	N. C.	-	Keep this pin Open.
7	N. C.	-	Keep this pin Open.
8	N. C.	-	Keep this pin Open.

4.6.3 Touch panel

CN3 (FPC)

Adaptable socket: FH28-40S-0.5SH(05) (Hirose Electric Co., Ltd.(HRS))

Pin No.	Symbol	Signal	Pin No.	Symbol	Signal
1	GND	Ground Note1	21	X13	X line terminal
2	GND	Ground Note1	22	X12	X line terminal
3	X31	X line terminal	23	X11	X line terminal
4	X30	X line terminal	24	X10	X line terminal
5	X29	X line terminal	25	X9	X line terminal
6	X28	X line terminal	26	X8	X line terminal
7	X27	X line terminal	27	X7	X line terminal
8	X26	X line terminal	28	X6	X line terminal
9	X25	X line terminal	29	X5	X line terminal
10	X24	X line terminal	30	X4	X line terminal
11	X23	X line terminal	31	X3	X line terminal
12	X22	X line terminal	32	X2	X line terminal
13	X21	X line terminal	33	X1	X line terminal
14	X20	X line terminal	34	X0	X line terminal
15	X19	X line terminal	35	GND	Ground Note1
16	X18	X line terminal	36	GND	Ground Note1
17	X17	X line terminal	37	N. C.	-(Keep this pin open)
18	X16	X line terminal	38	N. C.	-(Keep this pin open)
19	X15	X line terminal	39	N. C.	-(Keep this pin open)
20	X14	X line terminal	40	N. C.	-(Keep this pin open)

Note1: All GND terminals should be used without any non-connected lines.

PRELIMINARY

NLT Technologies, Ltd.

NL10276BC20-18KH

CN4 (FPC)

Adaptable socket:

FH28-60S-0.5SH(05) (Hirose Electric Co., Ltd.(HRS))

Pin No.	Symbol	Signal	Pin No.	Symbol	Signal
1	GND	Ground Note1	31	Y28	Y line terminal
2	GND	Ground Note1	32	Y29	Y line terminal
3	Y0	Y line terminal	33	Y30	Y line terminal
4	Y1	Y line terminal	34	Y31	Y line terminal
5	Y2	Y line terminal	35	Y32	Y line terminal
6	Y3	Y line terminal	36	Y33	Y line terminal
7	Y4	Y line terminal	37	Y34	Y line terminal
8	Y5	Y line terminal	38	Y35	Y line terminal
9	Y6	Y line terminal	39	Y36	Y line terminal
10	Y7	Y line terminal	40	Y37	Y line terminal
11	Y8	Y line terminal	41	Y38	Y line terminal
12	Y9	Y line terminal	42	Y39	Y line terminal
13	Y10	Y line terminal	43	Y40	Y line terminal
14	Y11	Y line terminal	44	Y41	Y line terminal
15	Y12	Y line terminal	45	Y42	Y line terminal
16	Y13	Y line terminal	46	Y43	Y line terminal
17	Y14	Y line terminal	47	Y44	Y line terminal
18	Y15	Y line terminal	48	Y45	Y line terminal
19	Y16	Y line terminal	49	Y46	Y line terminal
20	Y17	Y line terminal	50	Y47	Y line terminal
21	Y18	Y line terminal	51	Y48	Y line terminal
22	Y19	Y line terminal	52	Y49	Y line terminal
23	Y20	Y line terminal	53	Y50	Y line terminal
24	Y21	Y line terminal	54	Y51	Y line terminal
25	Y22	Y line terminal	55	GND	Ground Note1
26	Y23	Y line terminal	56	GND	Ground Note1
27	Y24	Y line terminal	57	N. C.	- (Keep this pin open)
28	Y25	Y line terminal	58	N. C.	- (Keep this pin open)
29	Y26	Y line terminal	59	N. C.	- (Keep this pin open)
30	Y27	Y line terminal	60	N. C.	- (Keep this pin open)

Note1: All GND terminals should be used without any non-connected lines.

PRELIMINARY

NLT Technologies, Ltd.

NL10276BC20-18KH

4.6.4 Positions of plug and socket

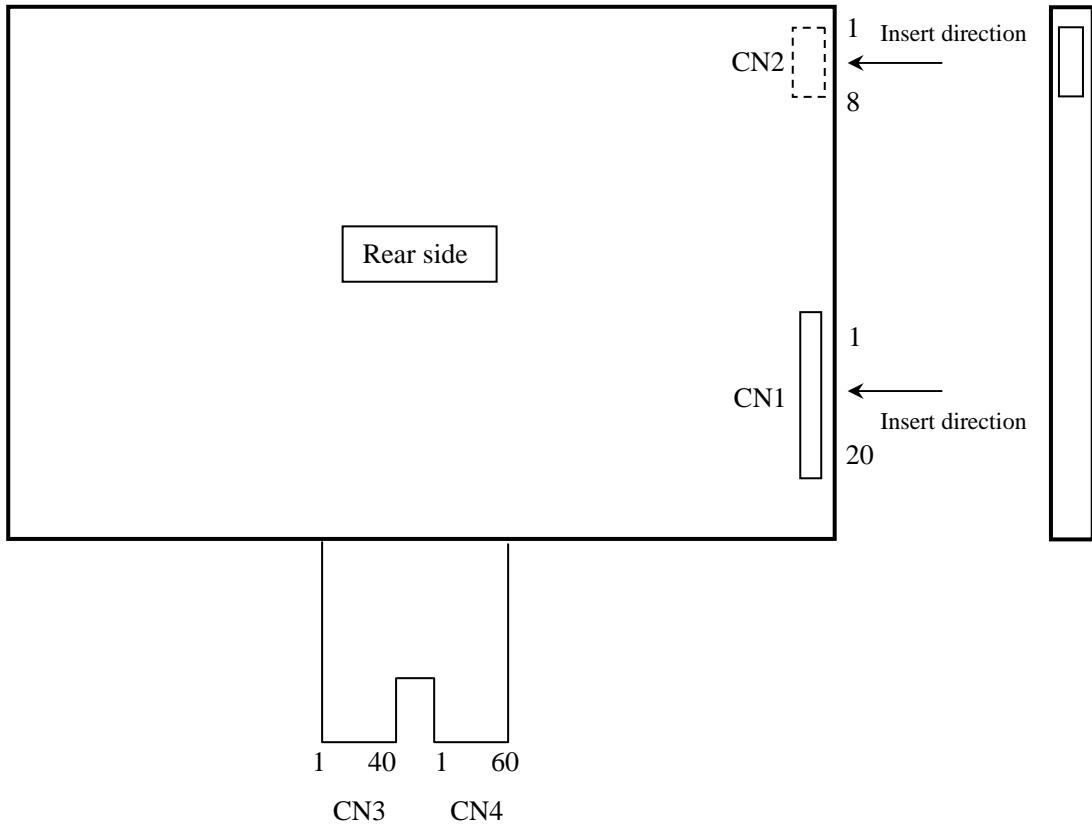

4.6.5 Connection between receiver and transmitter for LVDS

(1) Input data signal: 8bit, MAP A
Host

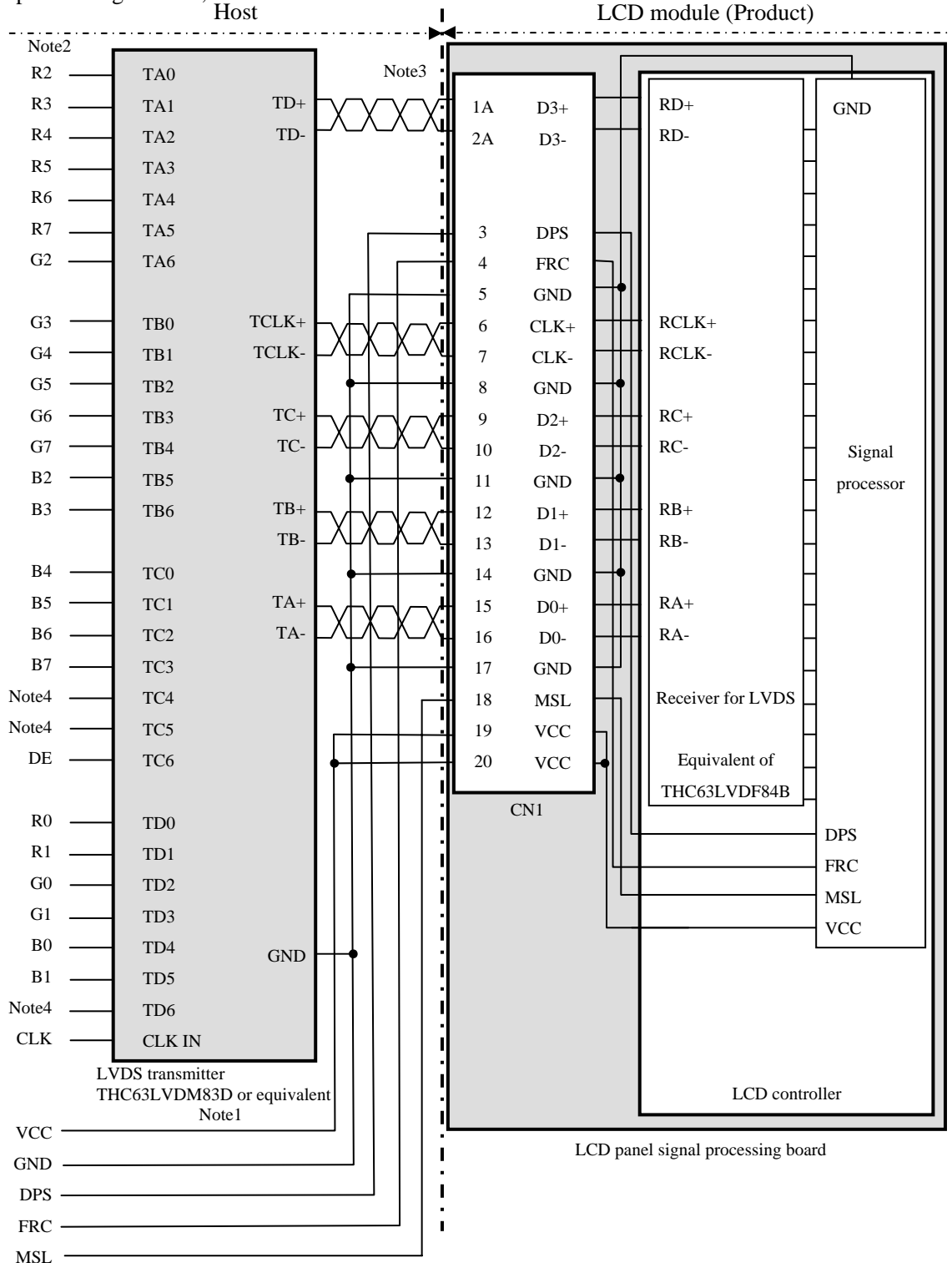

Note1: Recommended transmitter: THC63LVDM83D (THine Electronics Inc.) or equivalent

Note2: LSB (Least Significant Bit) – R0, G0, B0 MSB (Most Significant Bit) – R7, G7, B7

Note3: Twist pair wires with 100Ω (Characteristic impedance) should be used between LCD panel signal processing board and LVDS transmitter.

Note4: Input signals to TC4, TC5 and TD6 are not used inside the product, but do not keep TC4, TC5 and TD6 open to avoid noise problem.

PRELIMINARY

(2) Input data signal: 8bit, MAP B

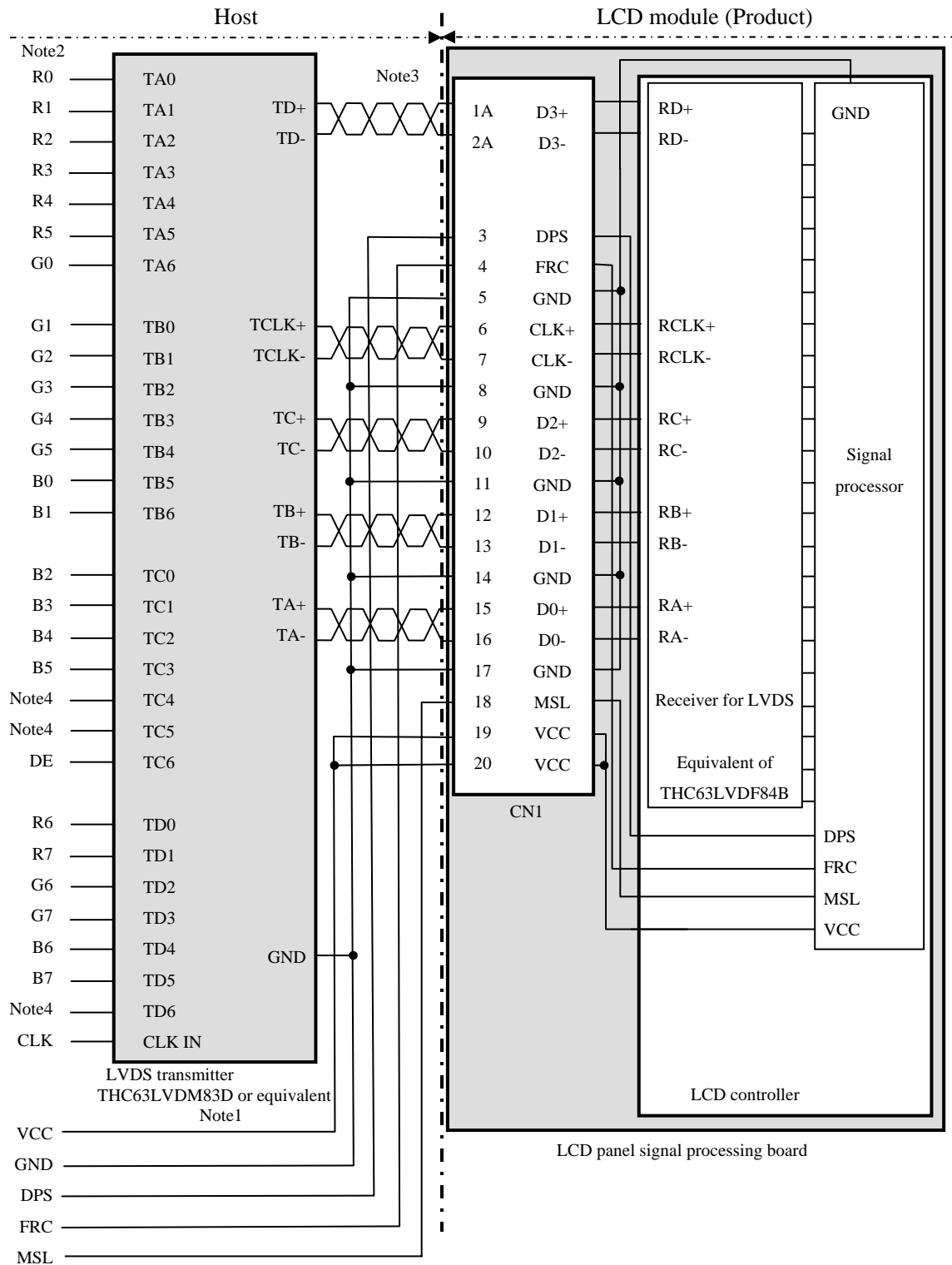

Note1: Recommended transmitter: THC63LVDM83D (THine Electronics Inc.) or equivalent

Note2: LSB (Least Significant Bit) – R0, G0, B0 MSB (Most Significant Bit) – R7, G7, B7

Note3: Twist pair wires with 100Ω (Characteristic impedance) should be used between LCD panel signal processing board and LVDS transmitter.

Note4: Input signals to TC4, TC5 and TD6 are not used inside the product, but do not keep TC4, TC5 and TD6 open to avoid noise problem.

PRELIMINARY

(3) Input data signal: 6bit

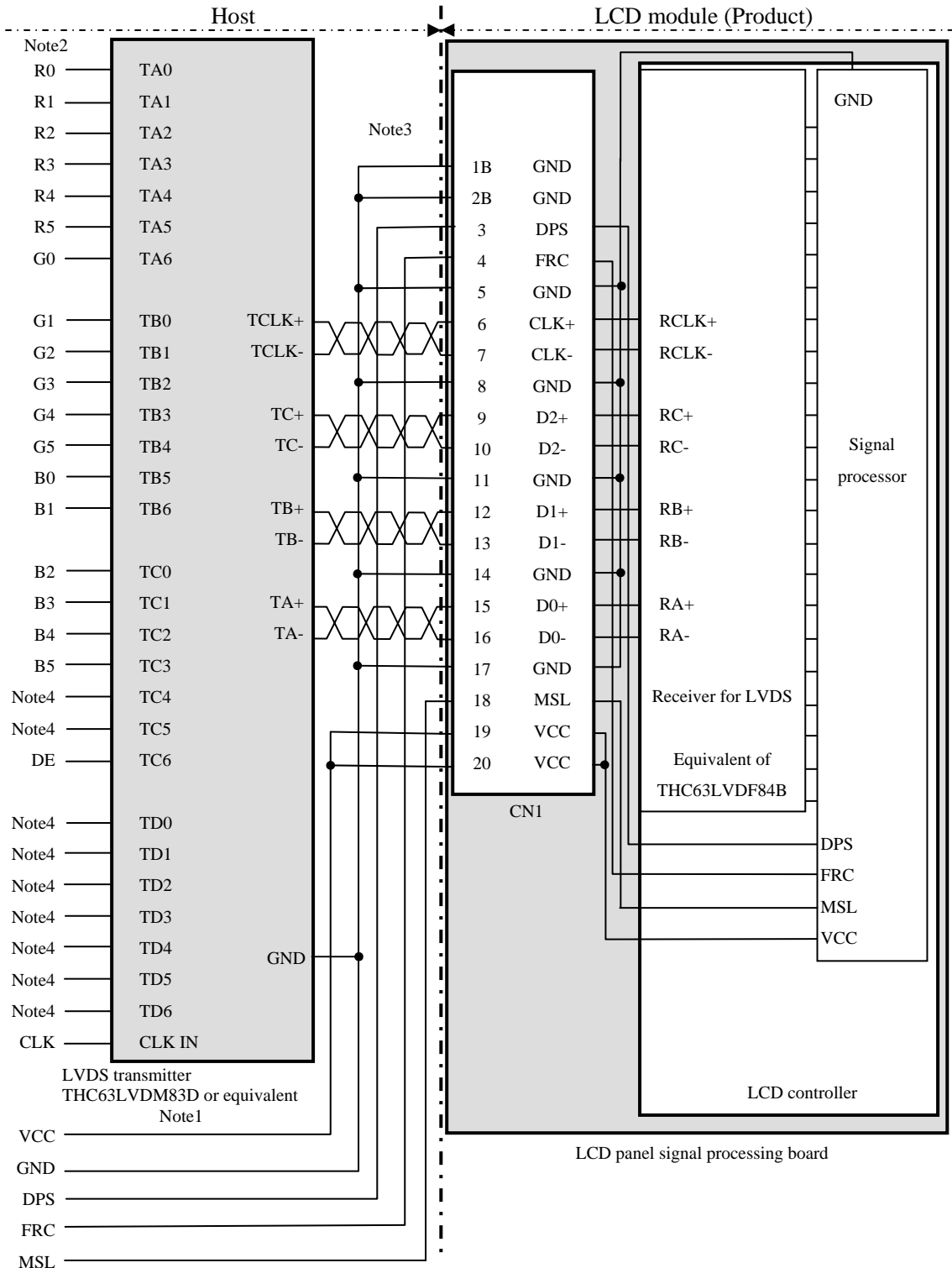

Note1: Recommended transmitter THC63LVDM83D (THine Electronics Inc.) or equivalent

Note2: LSB (Least Significant Bit) – R0, G0, B0 MSB (Most Significant Bit) – R5, G5, B5

Note3: Twist pair wires with 100Ω (Characteristic impedance) should be used between LCD panel signal processing board and LVDS transmitter.

Note4: Input signals to TC4, TC5 and TD0-6 are not used inside the product, but do not keep TC4, TC5 and TD0-6 open to avoid noise problem.

4.6.6 Input data mapping

(1) Input data signal: 8bit, MAP A

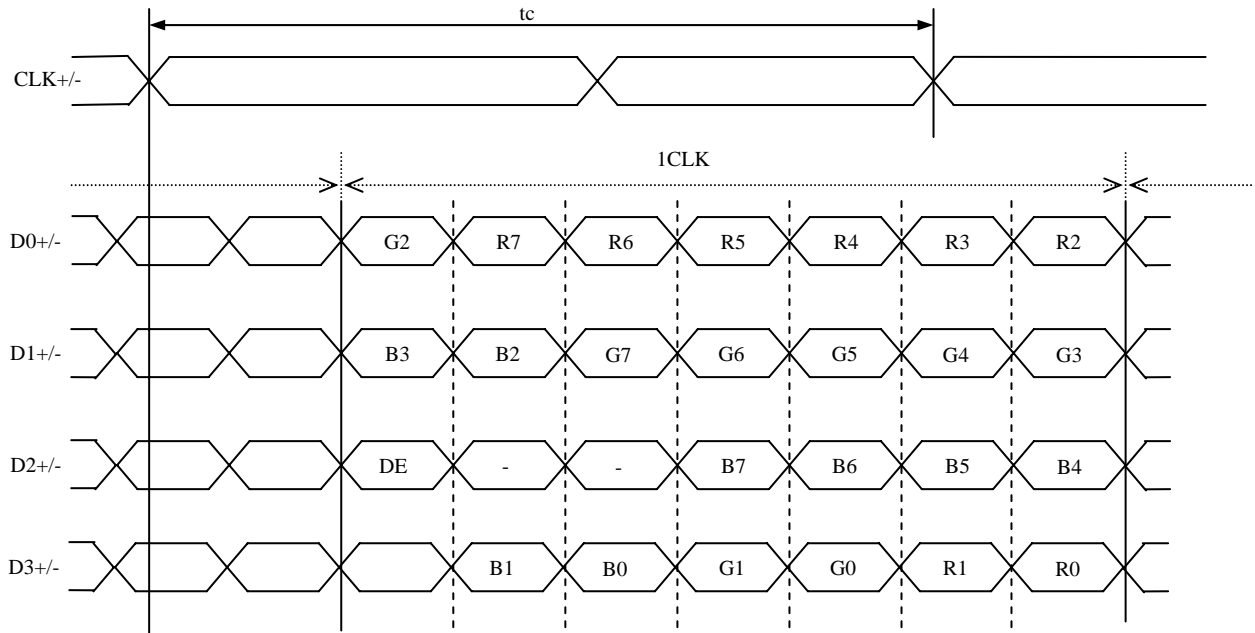

(2) Input data signal: 8bit, MAP B

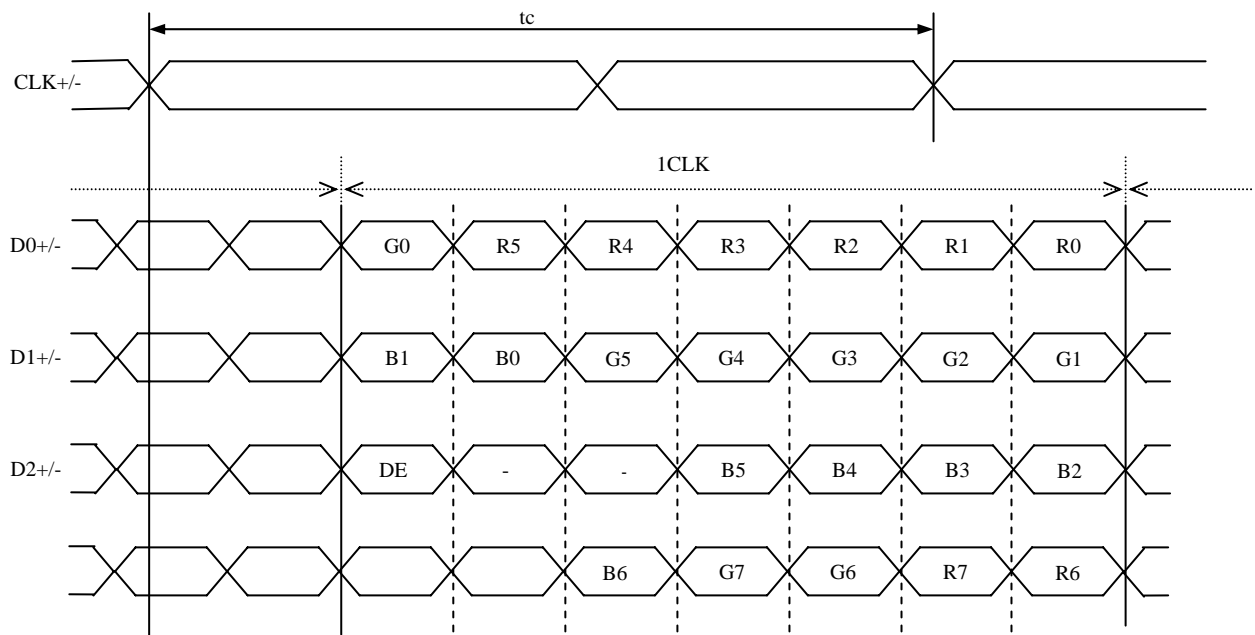

(3) Input data signal: 6bit

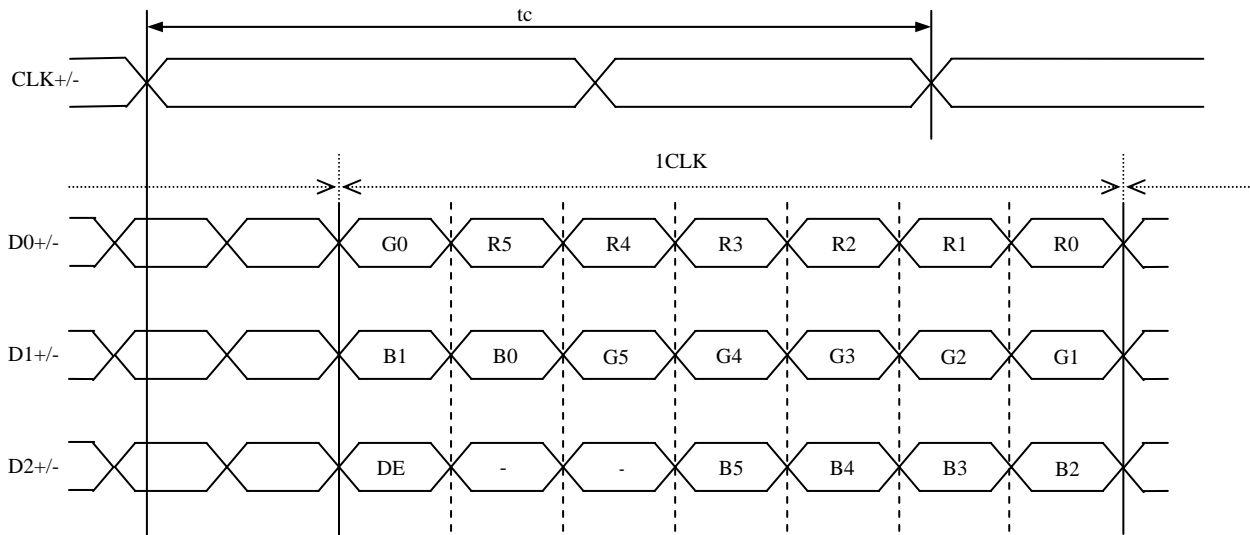

4.7 DISPLAY COLORS AND INPUT DATA SIGNALS

4.7.1 Combinations of input data signals, FRC and MSL signals

This product can display 16,777,216 colors equivalent with 256 gray scales and 262,144 colors with 64 gray scales by combination of input data signals, FRC and MSL signals. See the following table.

Combination	Input data signals	Input Data mapping	CN1- Pin No.1 and 2	FRC terminal	MSL terminal	Display colors	Remarks
①	8 bit	MAP A	D3+/-	High	Low	16,777,216	Note1
②	8 bit	MAP B	D3+/-	High	High	16,777,216	Note1
③	6 bit	-	GND	Low or Open	Low	262,144	Note2

Note1: See "4.7.2 16,777,216 colors".

Note2: See "4.7.3 262,144 colors".

PRELIMINARY

4.7.2 16,777,216 colors

This product can display 16,777,216 colors equivalent with 256 gray scales by combination ① or ②.
(See "4.7.1 Combinations of input data signals, FRC and MSL signals".)

Also the relation between display colors and input data signals is as follows.

Display colors		Data signal (0: Low level, 1: High level)																							
		R7	R6	R5	R4	R3	R2	R1	R0	G7	G6	G5	G4	G3	G2	G1	G0	B7	B6	B5	B4	B3	B2	B1	B0
Basic Colors	Black	0	0	0	0	0	0	0	0	0	0	0	0	0	0	0	0	0	0	0	0	0	0	0	0
	Blue	0	0	0	0	0	0	0	0	0	0	0	0	0	0	0	0	1	1	1	1	1	1	1	1
	Red	1	1	1	1	1	1	1	1	0	0	0	0	0	0	0	0	0	0	0	0	0	0	0	0
	Magenta	1	1	1	1	1	1	1	1	0	0	0	0	0	0	0	0	1	1	1	1	1	1	1	1
	Green	0	0	0	0	0	0	0	0	1	1	1	1	1	1	1	1	0	0	0	0	0	0	0	0
	Cyan	0	0	0	0	0	0	0	0	1	1	1	1	1	1	1	1	1	1	1	1	1	1	1	1
	Yellow	1	1	1	1	1	1	1	1	1	1	1	1	1	1	1	1	0	0	0	0	0	0	0	0
	White	1	1	1	1	1	1	1	1	1	1	1	1	1	1	1	1	1	1	1	1	1	1	1	1
Red gray scale	Black	0	0	0	0	0	0	0	0	0	0	0	0	0	0	0	0	0	0	0	0	0	0	0	0
	dark	0	0	0	0	0	0	0	1	0	0	0	0	0	0	0	0	0	0	0	0	0	0	0	0
	↑ ↓				:								:								:				
	bright	1	1	1	1	1	1	0	1	0	0	0	0	0	0	0	0	0	0	0	0	0	0	0	0
	Red	1	1	1	1	1	1	1	1	0	0	0	0	0	0	0	0	0	0	0	0	0	0	0	0
Green gray scale	Black	0	0	0	0	0	0	0	0	0	0	0	0	0	0	0	0	0	0	0	0	0	0	0	0
	dark	0	0	0	0	0	0	0	0	0	0	0	0	0	0	0	1	0	0	0	0	0	0	0	0
	↑ ↓				:								:								:				
	bright	0	0	0	0	0	0	0	0	1	1	1	1	1	1	0	1	0	0	0	0	0	0	0	0
	Green	0	0	0	0	0	0	0	0	1	1	1	1	1	1	1	1	0	0	0	0	0	0	0	0
Blue gray scale	Black	0	0	0	0	0	0	0	0	0	0	0	0	0	0	0	0	0	0	0	0	0	0	0	0
	dark	0	0	0	0	0	0	0	0	0	0	0	0	0	0	0	0	0	0	0	0	0	0	0	1
	↑ ↓				:								:								:				
	bright	0	0	0	0	0	0	0	0	0	0	0	0	0	0	0	0	1	1	1	1	1	1	0	1
	Blue	0	0	0	0	0	0	0	0	0	0	0	0	0	0	0	0	1	1	1	1	1	1	1	0

PRELIMINARY

4.7.3 262,144 colors

This product can display 262,144 colors with 64 gray scales by combination ③.

(See "4.7.1 Combinations of input data signals, FRC and MSL signals".)

Also the relation between display colors and input data signals is as follows.

Display colors		Data signal (0: Low level, 1: High level)																	
		R5	R4	R3	R2	R1	R0	G5	G4	G3	G2	G1	G0	B5	B4	B3	B2	B1	B0
Basic colors	Black	0	0	0	0	0	0	0	0	0	0	0	0	0	0	0	0	0	0
	Blue	0	0	0	0	0	0	0	0	0	0	0	0	1	1	1	1	1	1
	Red	1	1	1	1	1	1	0	0	0	0	0	0	0	0	0	0	0	0
	Magenta	1	1	1	1	1	1	0	0	0	0	0	0	1	1	1	1	1	1
	Green	0	0	0	0	0	0	1	1	1	1	1	1	0	0	0	0	0	0
	Cyan	0	0	0	0	0	0	1	1	1	1	1	1	1	1	1	1	1	1
	Yellow	1	1	1	1	1	1	1	1	1	1	1	1	0	0	0	0	0	0
	White	1	1	1	1	1	1	1	1	1	1	1	1	1	1	1	1	1	1
Red gray scale	Black	0	0	0	0	0	0	0	0	0	0	0	0	0	0	0	0	0	0
	dark	0	0	0	0	0	1	0	0	0	0	0	0	0	0	0	0	0	0
	↑				:														
	↓				:														
	bright	1	1	1	1	0	1	0	0	0	0	0	0	0	0	0	0	0	0
Red	1	1	1	1	1	1	0	0	0	0	0	0	0	0	0	0	0	0	
Green gray scale	Black	0	0	0	0	0	0	0	0	0	0	0	0	0	0	0	0	0	0
	dark	0	0	0	0	0	0	0	0	0	0	1	0	0	0	0	0	0	0
	↑				:														
	↓				:														
	bright	0	0	0	0	0	0	1	1	1	1	0	1	0	0	0	0	0	0
Green	0	0	0	0	0	0	1	1	1	1	1	1	0	0	0	0	0	0	
Blue gray scale	Black	0	0	0	0	0	0	0	0	0	0	0	0	0	0	0	0	0	0
	dark	0	0	0	0	0	0	0	0	0	0	0	0	0	0	0	0	1	0
	↑				:														
	↓				:														
	bright	0	0	0	0	0	0	0	0	0	0	0	0	1	1	1	1	0	1
Blue	0	0	0	0	0	0	0	0	0	0	0	0	1	1	1	1	1	0	
Blue	0	0	0	0	0	0	0	0	0	0	0	0	1	1	1	1	1	1	

PRELIMINARY

4.8 DISPLAY POSITIONS

The following table is the coordinates per pixel (See "4.9 SCANNING DIRECTIONS").

C (0, 0)						
R	G	B				
C(0, 0)	C(1, 0)	. . .	C(X, 0)	. . .	C(1022, 0)	C(1023, 0)
C(0, 1)	C(1, 1)	. . .	C(X, 1)	. . .	C(1022, 1)	C(1023, 1)
.
.
.
C(0, Y)	C(1, Y)	. . .	C(X, Y)	. . .	C(1022, Y)	C(1023, Y)
.
.
.
C(0, 766)	C(1, 766)	. . .	C(X, 766)	. . .	C(1022, 766)	C(1023, 766)
C(0, 767)	C(1, 767)	. . .	C(X, 767)	. . .	C(1022, 767)	C(1023, 767)

4.9 SCANNING DIRECTIONS

The following figures are seen from a front view.

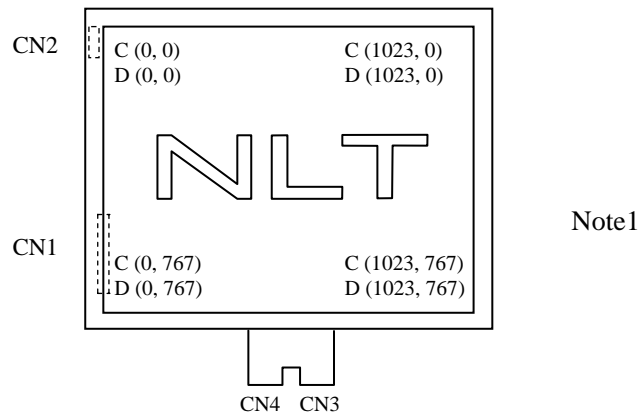

Figure1. Normal scan (DPS: Low or Open)

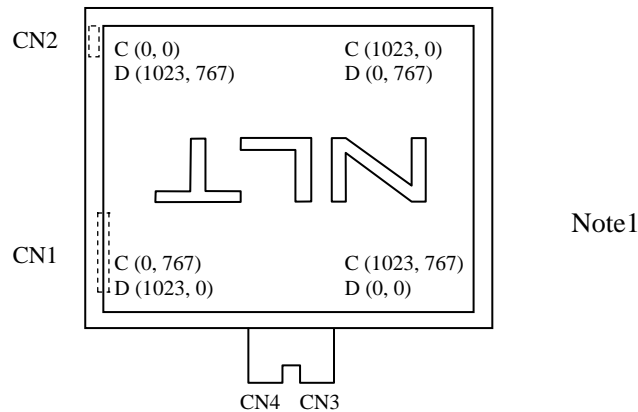

Figure2. Reverse scan (DPS: High)

Note1: Meaning of C (X, Y) and D (X, Y)

C (X, Y): The coordinates of the display position (See "4.8 DISPLAY POSITIONS").

D (X, Y): The data number of input signal for LCD panel signal processing board

4.10 INPUT SIGNAL TIMINGS

4.10.1 Outline of input signal timings

- Horizontal signal

Note1

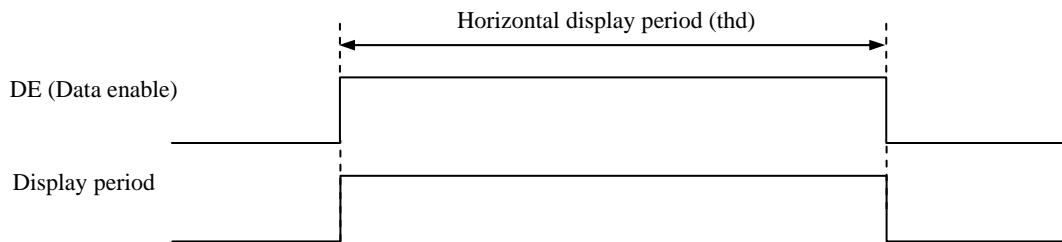

- Vertical signal

Note1

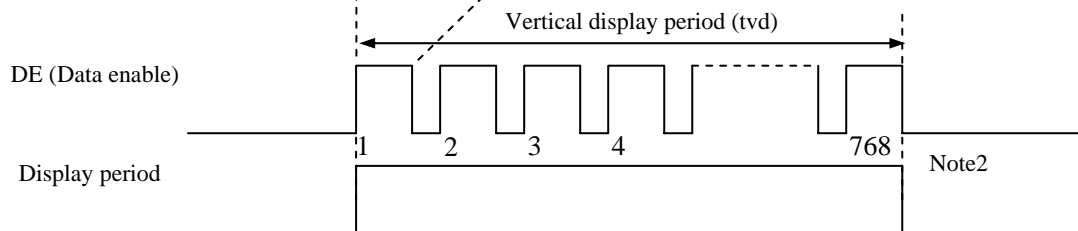

Note1: This diagram indicates virtual signal for set up to timing.

Note2: See "4.10.3 Input signal timing chart" for the pulse number.

PRELIMINARY

4.10.2 Timing characteristics

(Note1, Note2, Note3)

Parameter		Symbol	min.	typ.	max.	Unit	Remarks	
CLK	Frequency	1/tc	60.0	65.0	68.0	MHz	15.385 ns (typ.)	
	Duty	-	-			-	-	
	Rise time, Fall time	-				ns		
DATA	CLK-DATA	Setup time	-			ns	-	
		Hold time				ns		
	Rise time, Fall time	-				ns		
DE	Horizontal	Cycle	th	19.67	20.676	22.4	μs	48.363 kHz (typ.)
		Display period	thd	1,024			CLK	
	Vertical (One frame)	Cycle	tv	13.3	16.666	18.5	ms	
		Display period	tvd	780			H	
	CLK-DE	Setup time	-	-			ns	-
		Hold time	-				ns	
Rise time, Fall time		-	ns					

Note1: Definition of parameters is as follows.

$$tc = 1CLK, th = 1H$$

Note2: See the data sheet of LVDS transmitter.

Note3: Vertical cycle (tv) should be specified in integral multiple of Horizontal cycle (th).

4.10.3 Input signal timing chart

Horizontal timing

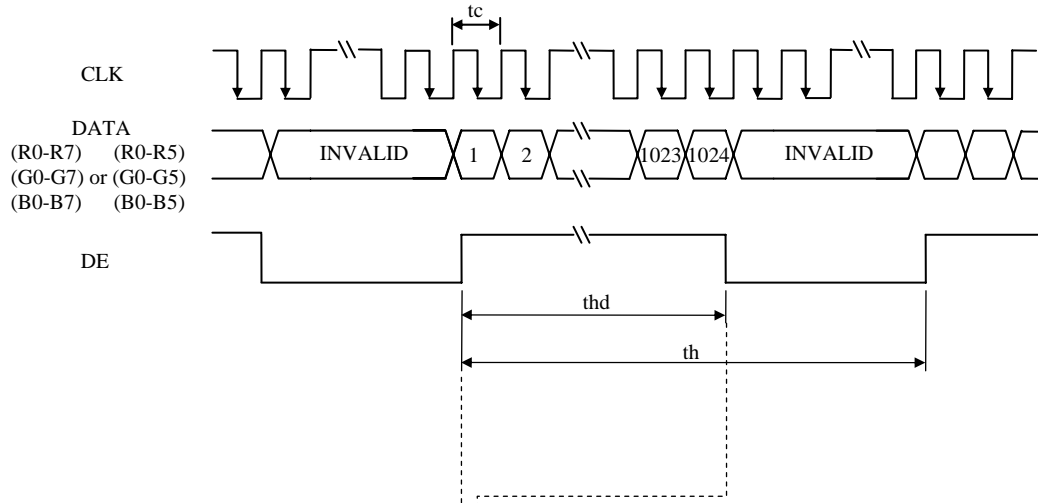

Vertical timing

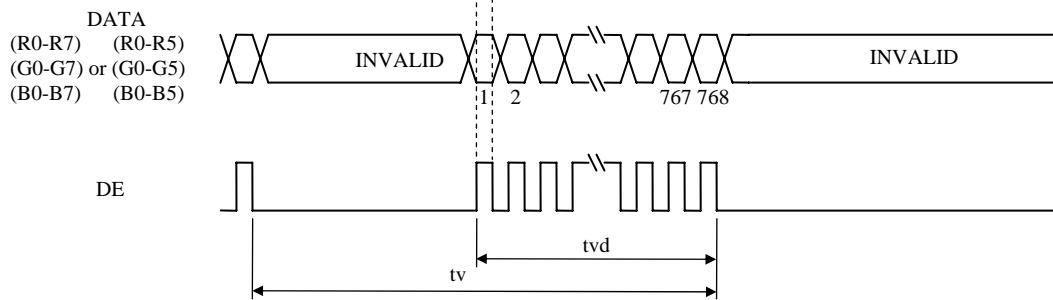

PRELIMINARY

4.11 OPTICS

4.11.1 Optical characteristics

(Note1, Note2)

Parameter	Condition	Symbol	min.	typ.	max.	Unit	Measuring instrument	Remarks	
Luminance	White at center $\theta R=0^\circ, \theta L=0^\circ, \theta U=0^\circ, \theta D=0^\circ$	L	TBD	(780)	-	cd/m ²	BM-5A	-	
Contrast ratio	White/Black at center $\theta R=0^\circ, \theta L=0^\circ, \theta U=0^\circ, \theta D=0^\circ$	CR	TBD	TBD	-	-	BM-5A	Note3	
Luminance uniformity	White $\theta R=0^\circ, \theta L=0^\circ, \theta U=0^\circ, \theta D=0^\circ$	LU	-	1.25	1.4	-	BM-5A	Note4	
Chromaticity	White	x coordinate	Wx	TBD	(0.313)	TBD	-	SR-3	Note5
		y coordinate	Wy	TBD	(0.329)	TBD	-		
	Red	x coordinate	Rx	-	(0.543)	-	-		
		y coordinate	Ry	-	(0.337)	-	-		
	Green	x coordinate	Gx	-	(0.357)	-	-		
		y coordinate	Gy	-	(0.547)	-	-		
Blue	x coordinate	Bx	-	(0.156)	-	-			
	y coordinate	By	-	(0.124)	-	-			
Color gamut	$\theta R=0^\circ, \theta L=0^\circ, \theta U=0^\circ, \theta D=0^\circ$ at center, against NTSC color space	C	35	40	-	%			
Response time	White to Black	Ton	-	3	5	ms	BM-5A	Note6	
	Black to White	Toff	-	15	21	ms	-10000	Note7	
Viewing angle	Right	$\theta U=0^\circ, \theta D=0^\circ, CR \geq 10$	θR	(70)	(80)	-	°	BM-5A or EZ Contrast	Note8
	Left	$\theta U=0^\circ, \theta D=0^\circ, CR \geq 10$	θL	(70)	(80)	-	°		
	Up	$\theta R=0^\circ, \theta L=0^\circ, CR \geq 10$	θU	(70)	(80)	-	°		
	Down	$\theta R=0^\circ, \theta L=0^\circ, CR \geq 10$	θD	(70)	(80)	-	°		

Note1: These are initial characteristics.

Note2: Measurement conditions are as follows.

Ta= 25°C, VCC= 3.3V, IL= 60mA/one circuit, Display mode: XGA, Horizontal cycle= 1/48.363kHz, Vertical cycle= 1/60.0Hz, DPS= Low or Open: Normal scan

Optical characteristics are measured at luminance saturation after 20minutes from working the product, in the dark room. Also measurement methods are as follows.

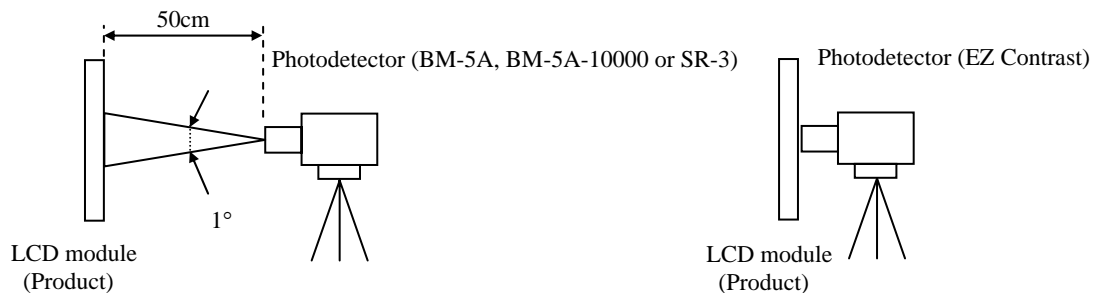

Note3: See "4.11.2 Definition of contrast ratio".

Note4: See "4.11.3 Definition of luminance uniformity".

Note5: These coordinates are found on CIE 1931 chromaticity diagram.

Note6: Product surface temperature: TopF= 28°C

Note7: See "4.11.4 Definition of response times".

Note8: See "4.11.5 Definition of viewing angles".

4.11.2 Definition of contrast ratio

The contrast ratio is calculated by using the following formula.

$$\text{Contrast ratio (CR)} = \frac{\text{Luminance of white screen}}{\text{Luminance of black screen}}$$

4.11.3 Definition of luminance uniformity

The luminance uniformity is calculated by using following formula.

$$\text{Luminance uniformity (LU)} = \frac{\text{Maximum luminance from ① to ⑤}}{\text{Minimum luminance from ① to ⑤}}$$

The luminance is measured at near the 5 points shown below.

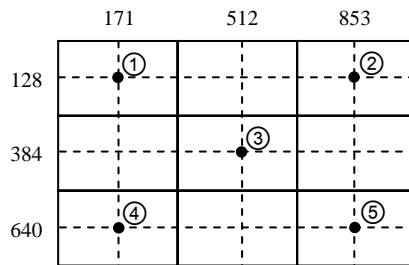

4.11.4 Definition of response times

Response time is measured at the time when the luminance changes from " white " to " black ", or " black " to " white " on the same screen point, by photo-detector. Ton is the time when the luminance changes from 90% down to 10%. Also Toff is the time when the luminance changes from 10% up to 90% (See the following diagram.).

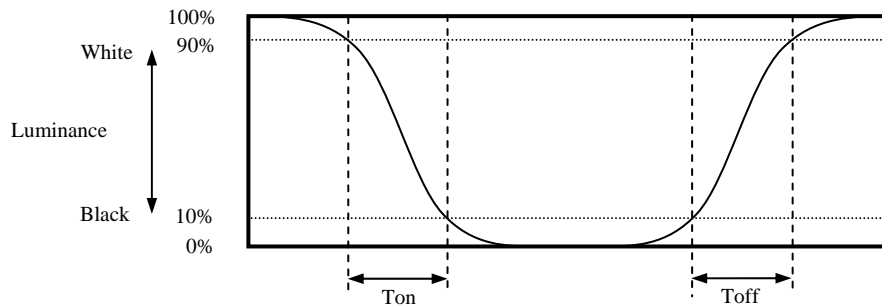

4.11.5 Definition of viewing angles

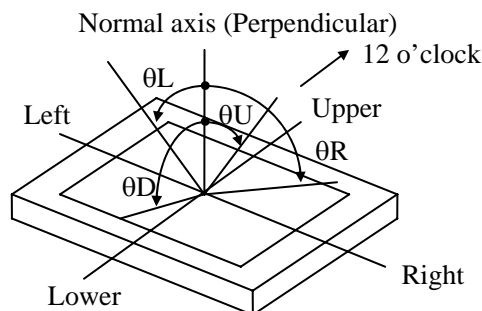

PRELIMINARY

5. ESTIMATED LUMINANCE LIFETIME

The luminance lifetime is the time from initial luminance to half-luminance.

This lifetime is the estimated value, and is not guarantee value.

Condition		Estimated luminance lifetime (Life time expectancy) Note1, Note2, Note3	Unit
LED elementary substance	25°C (Ambient temperature of the product) Continuous operation, IL= 60mA/one circuit	70,000	h
	80°C (Surface temperature at screen) Continuous operation, IL= 60mA/one circuit	60,000	h

Note1: Life time expectancy is mean time to half-luminance.

Note2: Estimated luminance lifetime is not the value for an LCD module but the value for LED elementary substance.

Note3: By ambient temperature, the lifetime changes particularly. Especially, in case the product works under high temperature environment, the lifetime becomes short.

PRELIMINARY

6. RELIABILITY TESTS

Test item	Condition	Judgment	Note1
High temperature and humidity (Operation)	① $60 \pm 2^{\circ}\text{C}$, RH= 90%, 240hours Note3, Note4 ② Display data is black.	No display malfunctions	
High temperature (Operation)	① $(80) \pm 3^{\circ}\text{C}$, 240hours Note3, Note4 ② Display data is black.		
Heat cycle (Operation)	① $-30 \pm 3^{\circ}\text{C} \dots 1\text{hour}$ $(80) \pm 3^{\circ}\text{C} \dots 1\text{hour}$ Note3, Note4 ② 50cycles, 4 hours/cycle ③ Display data is black.		
Thermal shock (Non operation)	① $-30 \pm 3^{\circ}\text{C} \dots 30\text{minutes}$ $80 \pm 3^{\circ}\text{C} \dots 30\text{minutes}$ ② 100cycles, 1hour/cycle ③ Temperature transition time is within 5 minutes.		
ESD (Operation)	① 150pF, 150Ω, $\pm 10\text{kV}$ ② 9 places on a panel surface Note2 ③ 10 times each places at 1 sec interval		
Dust (Operation)	① Sample dust: No. 15 (by JIS-Z8901) ② 15 seconds stir ③ 8 times repeat at 1 hour interval		
Vibration (Non operation)	① 5 to 100Hz, 19.6m/s^2 ② 1 minute/cycle ③ X, Y, Z directions ④ 120 times each directions	No display malfunctions No physical damages	
Mechanical shock (Non operation)	① 539m/s^2 , 11ms ② $\pm X, \pm Y, \pm Z$ directions ③ 5 times each directions		

Note1: Display and appearance are checked under environmental conditions equivalent to the inspection conditions of defect criteria.

Note2: See the following figure for discharge points.

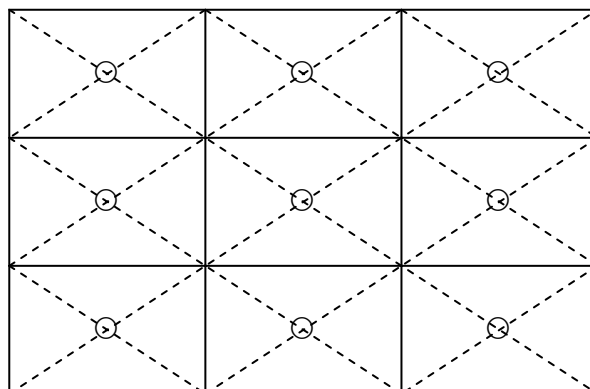

Note3: Measured at LCD panel surface (including self-heat)

Note4: Measured at LCD module's rear shield surface (including self-heat)

7. PRECAUTIONS

7.1 MEANING OF CAUTION SIGNS

The following caution signs have very important meaning. **Be sure to read "7.2 CAUTIONS" and "7.3 ATTENTIONS"!**



This sign has the meaning that a customer will be injured or the product will sustain damage if the customer practices wrong operations.



This sign has the meaning that a customer will be injured if the customer practices wrong operations.

7.2 CAUTIONS



- * **Be taken care when handling the touch panel. There is a danger of injury, because the touch panel has the glass edge and corner which are sharp.**
- * **Do not shock and press the LCD panel and the backlight! There is a danger of breaking, because they are made of glass. (Shock: Equal to or no greater than 539m/s^2 and equal to or no greater than 11ms, Pressure: Equal to or no greater than 19.6 N ($\phi 16\text{mm}$ jig))**

7.3 ATTENTIONS



7.3.1 Handling of the product

- ① Use gloves or fingerstalls and do not touch glass edge of touch panel when handling it, because it has sharp glass edge.

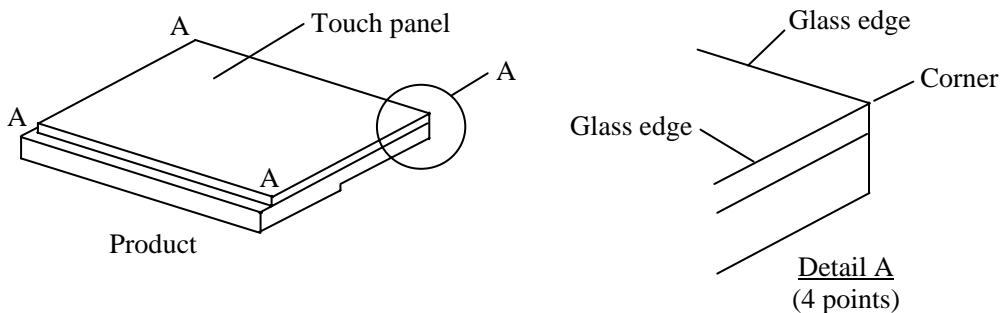

- ② Take hold of both ends without touching the circuit board when the product (LCD module) is picked up from inner packing box to avoid broken down or misadjustment, because of stress to mounting parts on the circuit board.
- ③ When the product is put on the table temporarily, display surface must be placed downward.
- ④ When handling the product, take the measures of electrostatic discharge with such as earth band, ionic shower and so on, because the product may be damaged by electrostatic.
- ⑤ The torque for product mounting screws must never exceed 0.147 N·m. Higher torque might result in distortion of the bezel. And the length of product mounting screws must be $\leq 2.0\text{mm}$.
- ⑥ The product must be installed using mounting holes without undue stress such as bends or twist (See outline drawings). And do not add undue stress to any portion (such as bezel flat area). Bends or twist described above and undue stress to any portion may cause display mura.
- ⑦ Do not hit or rub the surface of touch panel with hard materials, because it is easily scratched. (Touch panel pencil-hardness: (2)H)

- ⑧ When cleaning the T/P surface, wipe it with a soft dry cloth.
- ⑨ Do not push nor pull the interface connectors while the product is working.
- ⑩ When handling the product, use of an original protection sheet on the product surface (polarizer) is recommended for protection of product surface. Adhesive type protection sheet may change color or characteristics of the polarizer.
- ⑪ Usually liquid crystals don't leak through the breakage of glasses because of the surface tension of thin layer and the construction of LCD panel. But, if you contact with liquid crystal for the worst, please wash it away with soap and water.
- ⑫ If the product is subjected to direct sunlight for a long time, touch panel transmission may be degraded.

7.3.2 Environment

- ① Do not operate or store in high temperature, high humidity, dewdrop atmosphere or corrosive gases. Keep the product in packing box with antistatic pouch in room temperature to avoid dusts and sunlight, when storing the product.
- ② In order to prevent dew condensation occurred by temperature difference, the product packing box must be opened after enough time being left under the environment of an unpacking room. Evaluate the storage time sufficiently because dew condensation is affected by the environmental temperature and humidity. (Recommended leaving time: 6 hours or more with the original packing state after a customer receives the package)
- ③ Do not operate in high magnetic field. If not, circuit boards may be broken.
- ④ This product is not designed as radiation hardened.

7.3.3 Characteristics

The following items are neither defects nor failures.

- ① Characteristics of the LCD (such as response time, luminance, color uniformity and so on) may be changed depending on ambient temperature. If the product is stored under condition of low temperature for a long time, it may cause display mura. In this case, the product should be operated after enough time being left under condition of operating temperature.
- ② Display mura, flickering, vertical streams or tiny spot may be observed depending on display patterns.
- ③ Do not display the fixed pattern for a long time because it may cause image sticking. Use a screen saver, if the fixed pattern is displayed on the screen.
- ④ The display color may be changed depending on viewing angle because of the use of condenser sheet in the backlight.
- ⑤ Optical characteristics may be changed depending on input signal timings.
- ⑥ Touch panel film has polarizing characteristic. And the polarizer characteristics differ among products. Therefore, when seeing the displays through the other polarizing material (for example polarizing sunglasses), some displays can not be seen and some displays look different color darker because of polarizer characteristic mismatching between touch panel film and the other polarizing material.

7.3.4 Others

- ① All GND and VCC terminals should be used without any non-connected lines.
- ② Do not disassemble a product or adjust variable resistors.
- ③ See "REPLACEMENT MANUAL FOR LAMP HOLDER SET", when replacing lamp holder set.
- ④ Pack the product with original shipping package, in order to avoid any damages during transportation, when returning the product to NLT for repair and so on.

8. OUTLINE DRAWINGS

8.1 FRONT VIEW

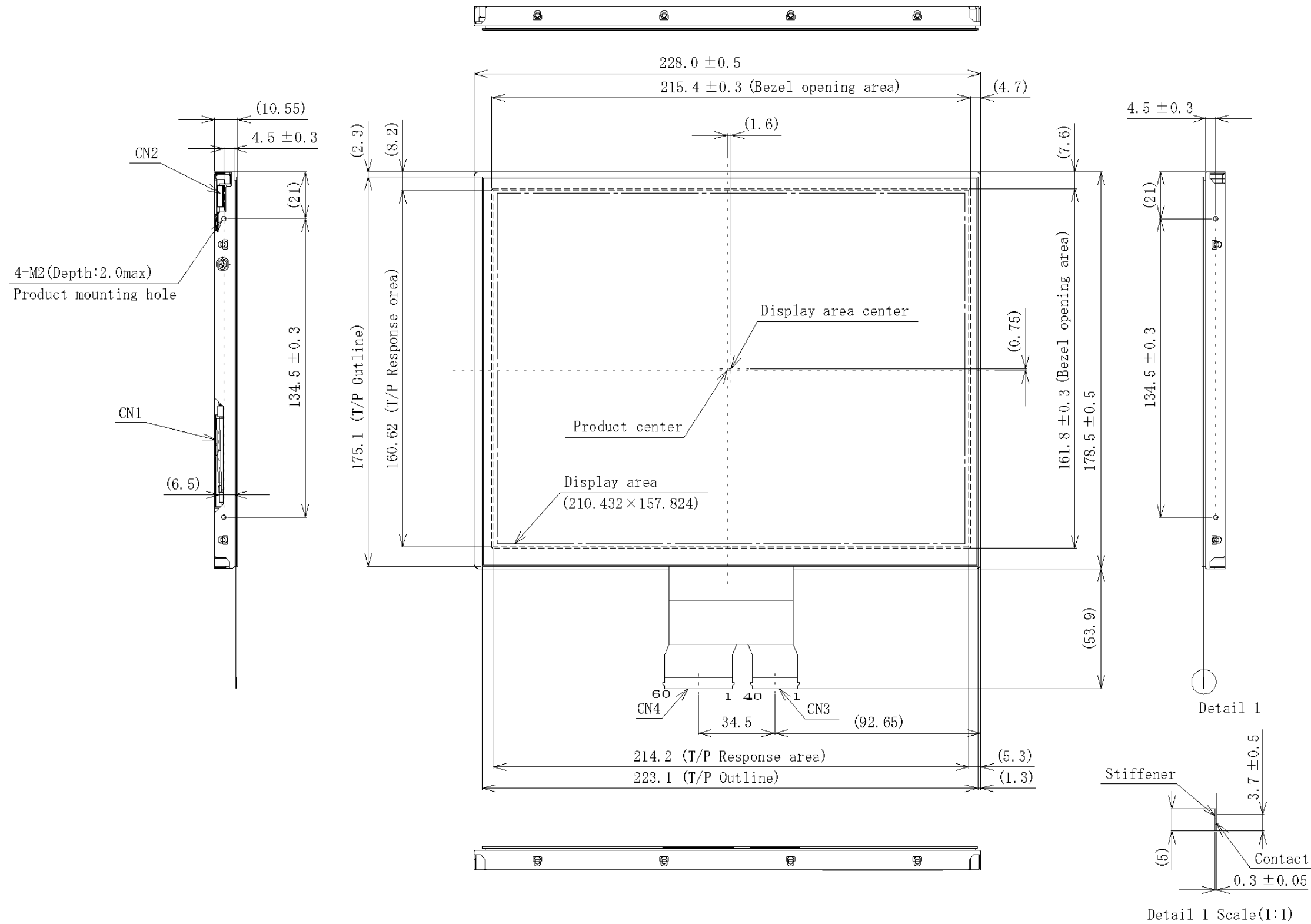

Note1: The values in parentheses are for reference.

Note2: The torque for product mounting screws must never exceed 0.147N·m. And the length of product mounting screws must be ≤ 2.0 mm.

Unit: mm

8.2 REAR VIEW

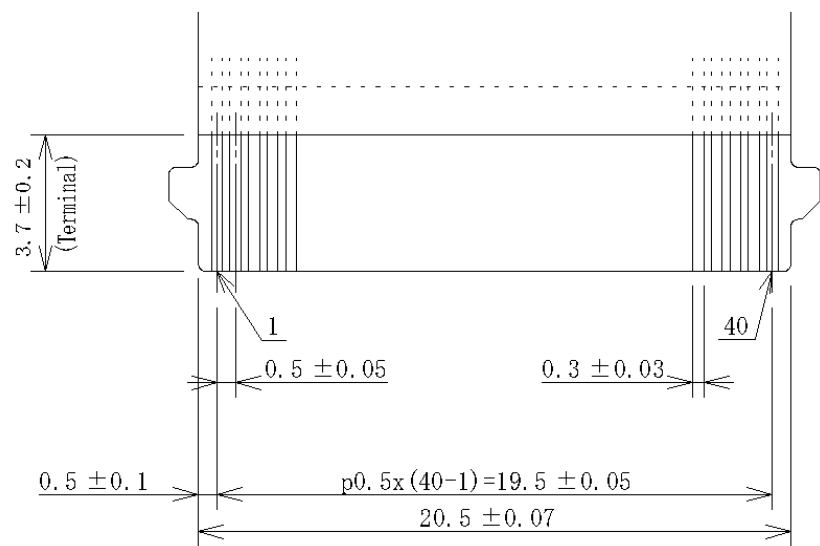
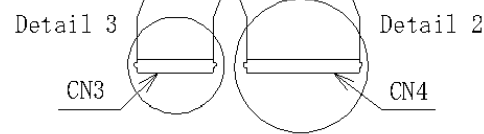
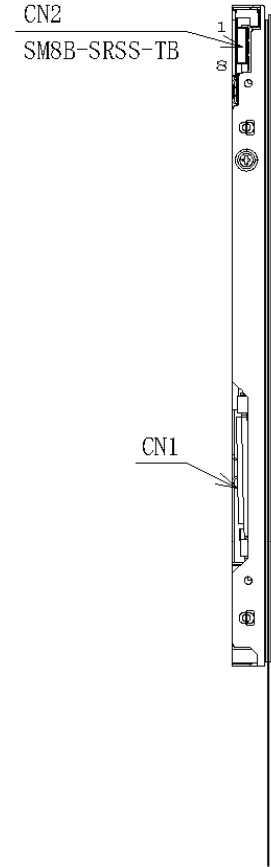
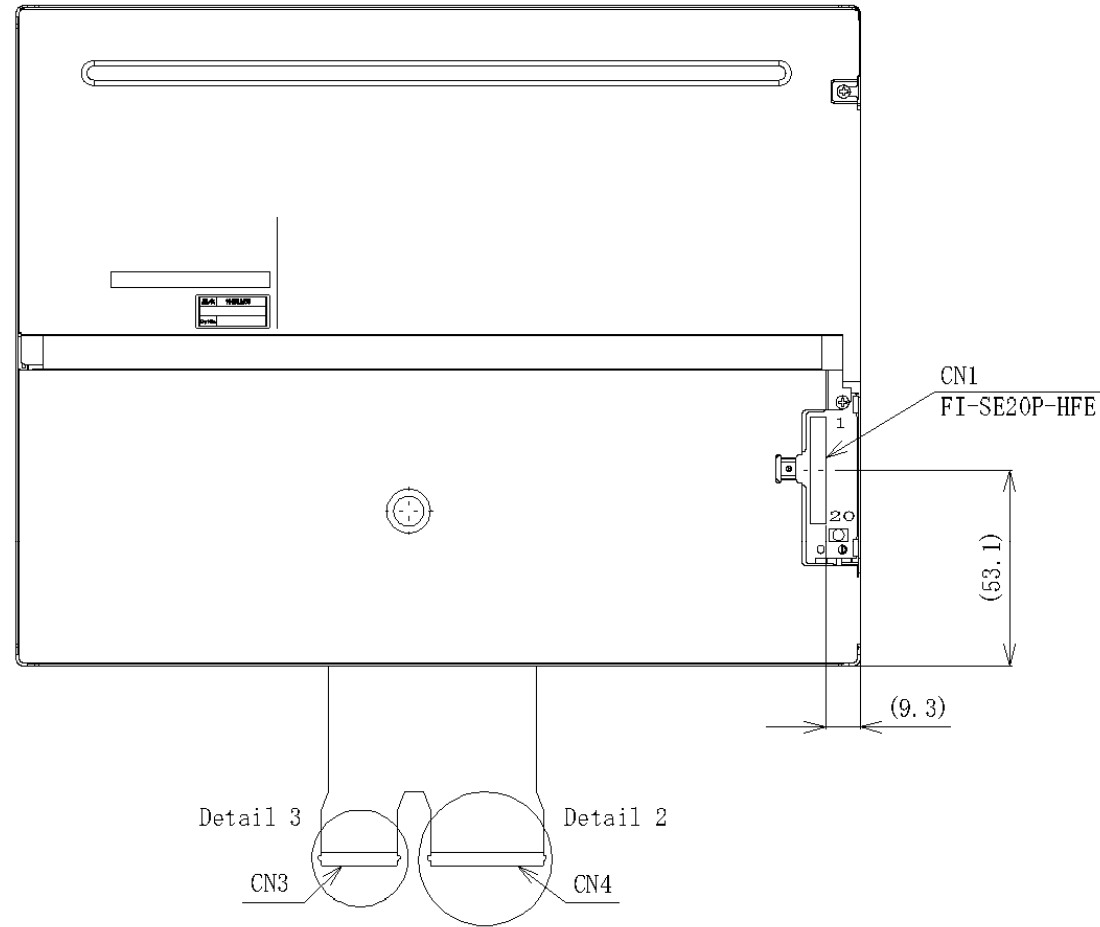

Adaptable socket: FH28-40S-0.5SH(05)

Detail 3 Scale(5:1)

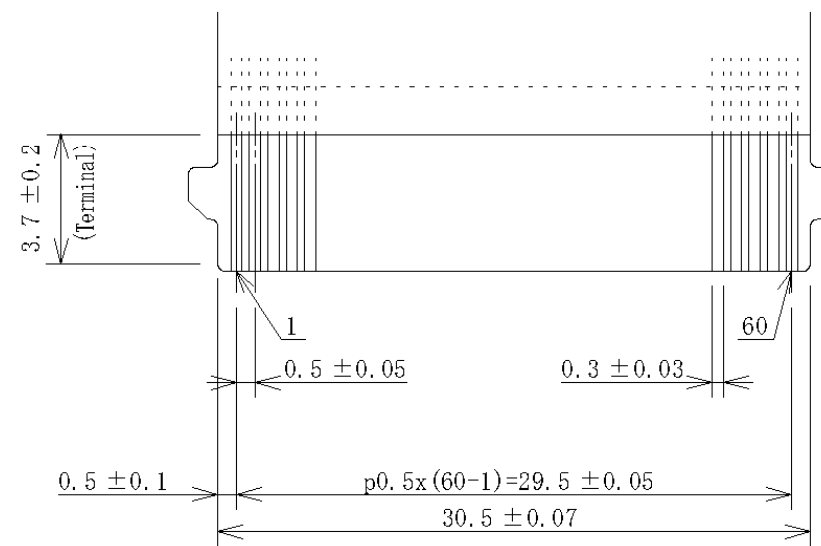

Adaptable socket: FH28-60S-0.5SH(05)

Detail 2 Scale(5:1)

INSTALL GUIDANCE

1. Bezel mounting

IF add front bezel on the touch panel, please take care following issue.

- Use front bezel make from insulative material, like plastic, or resin. If not, touch panel sensitivity will be blocked or unstable by this bezel.
- Settle the bezel out of touch panel active area. If not, touch panel sensitivity will be blocked or unstable by this bezel.
- Keep the distance between front bezel to touch panel over 1mm.

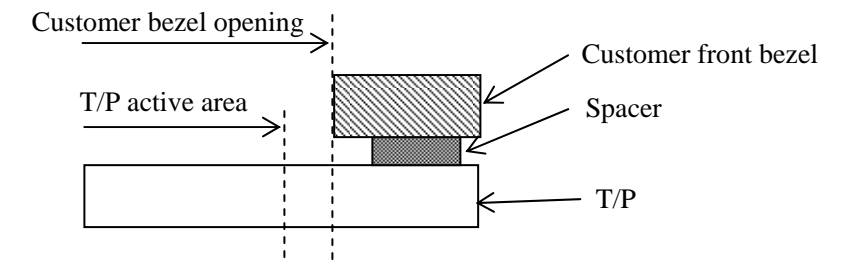

2. T/P FPC handles with care point

When bend the fpc, don't stress to the root area of fpc, nor bending so tight.

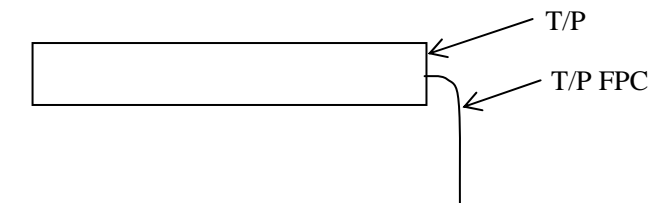

Note1: The values in parentheses are for reference.

Note2: The torque for product mounting screws must never exceed 0.147N·m. And the length of product mounting screws must be ≤ 2.0mm.

Unit: mm







PRELIMINARY

NLT Technologies, Ltd.

NL10276BC20-18KH

REVISION HISTORY

The inside of latest specifications is revised to the clerical error and the major improvement of previous edition. Only a changed part such as functions, characteristic value and so on that may affect a design of customers, are described especially below.

Edition	Document number	Prepared date	Revision contents and signature									
1st edition	DOD-PP-1552	Jan. 19, 2013	<p>Revision contents</p> <p>New issue</p> <p>Signature of writer</p> <table data-bbox="542 694 1404 817"><tr><td data-bbox="542 694 813 728"><i>Approved by</i></td><td data-bbox="821 694 1093 728"><i>Checked by</i></td><td data-bbox="1101 694 1404 728"><i>Prepared by</i></td></tr><tr><td data-bbox="542 728 813 772"></td><td data-bbox="821 728 1093 772">_____</td><td data-bbox="1101 728 1404 772"></td></tr><tr><td data-bbox="542 772 813 817">K. FUJIMOTO</td><td data-bbox="821 772 1093 817">_____</td><td data-bbox="1101 772 1404 817">A. KUMANO</td></tr></table>	<i>Approved by</i>	<i>Checked by</i>	<i>Prepared by</i>		_____		K. FUJIMOTO	_____	A. KUMANO
<i>Approved by</i>	<i>Checked by</i>	<i>Prepared by</i>										
	_____											
K. FUJIMOTO	_____	A. KUMANO										