

(V) Preliminary Specifications

() Final Specifications

| | |
|-------------------|-----------------------|
| Module | 15 Inch Color TFT-LCD |
| Model Name | G150XG01 V4 |

| | |
|----------------------------------------------------------------------|-------------|
| Customer | Date |
| _____ | _____ |
| Checked & Approved by | |
| _____ | _____ |
| <p>Note: This Specification is subject to change without notice.</p> | |

| | |
|-----------------------------------------------------------------|-------------------|
| Approved by | Date |
| <i>Vito Huang</i> | <i>2011/04/11</i> |
| Prepared by | |
| <i>Linda Lee</i> | <i>2011/04/11</i> |
| <p>Audio-Video Business Unit / AU Optronics corporation</p> | |

Contents

| | |
|----------------------------------------------------------------|-----------|
| 1. Operating Precautions | 4 |
| 2. General Description | 5 |
| 2.1 Display Characteristics..... | 5 |
| 2.2 Touch Characteristics..... | 6 |
| 2.3 Optical Characteristics | 7 |
| 3. Functional Block Diagram | 11 |
| 4. Absolute Maximum Ratings | 12 |
| 4.1 Absolute Ratings of TFT LCD Module | 12 |
| 4.2 Absolute Ratings of Environment | 12 |
| 5. Electrical Characteristics | 13 |
| 5.1 TFT LCD Module | 13 |
| 5.2 Backlight Unit..... | 15 |
| 5.3 Touch Unit..... | 15 |
| 6. Signal Characteristic | 16 |
| 6.1 Pixel Format Image | 16 |
| 6.2 Scanning Direction..... | 16 |
| 6.3 Signal Description | 17 |
| 6.4 The Input Data Format | 18 |
| 6.5 Interface Timing..... | 20 |
| 6.6 Power ON/OFF Sequence | 21 |
| 7. Connector & Pin Assignment | 23 |
| 7.1 TFT-LCD Signal: LVDS Interface Connector..... | 23 |
| 7.2 LED Backlight Unit: LED Driver Connector..... | 25 |
| 7.3 LED Driver Connector Pin Assignment | 25 |
| 8. Reliability Test Criteria | 26 |
| 9. Mechanical Characteristics | 27 |
| 9.1 LCM Outline Dimension (Front View) | 27 |
| 9.2 LCM Outline Dimension (Rear View)..... | 28 |
| 10. Label and Packaging | 29 |
| 10.1 Shipping Label (on the rear side of TFT-LCD display)..... | 29 |
| 10.2 Carton Package | 29 |
| 11 Safety | 30 |
| 11.1 Sharp Edge Requirements..... | 30 |
| 11.2 Materials | 30 |
| 11.3 Capacitors..... | 30 |
| 11.4 National Test Lab Requirement..... | 30 |



Record of Revision

| Version and Date | Page | Old description | New Description |
|-------------------------|-------------|------------------------|------------------------|
| Rev 0.1 2011/4/11 | All | First Edition | |
| | | | |
| | | | |
| | | | |
| | | | |
| | | | |
| | | | |

1. Operating Precautions

- 1) Since front polarizer is easily damaged, please be cautious and not to scratch it.
- 2) Be sure to turn off power supply when inserting or disconnecting from input connector.
- 3) Wipe off water drop immediately. Long contact with water may cause discoloration or spots.
- 4) When the panel surface is soiled, wipe it with absorbent cotton or soft cloth.
- 5) Since the panel is made of glass, it may be broken or cracked if dropped or bumped on hard surface.
- 6) Since CMOS LSI is used in this module, take care of static electricity and insure human earth when handling.
- 7) Do not open nor modify the module assembly.
- 8) Do not press the reflector sheet at the back of the module to any direction.
- 9) In case if a module has to be put back into the packing container slot after it was taken out from the container, do not press the center of the LED Reflector edge. Instead, press at the far ends of the LED Reflector edge softly. Otherwise the TFT Module may be damaged.
- 10) At the insertion or removal of the Signal Interface Connector, be sure not to rotate nor tilt the Interface Connector of the TFT Module.
- 11) TFT-LCD Module is not allowed to be twisted & bent even force is added on module in a very short time. Please design your display product well to avoid external force applying to module by end-user directly.
- 12) Small amount of materials without flammability grade are used in the TFT-LCD module. The TFT-LCD module should be supplied by power complied with requirements of Limited Power Source (IEC60950 or UL1950), or be applied exemption.
- 13) Severe temperature condition may result in different luminance, response time.
- 14) Continuous operating TFT-LCD Module under high temperature environment may accelerate LED light bar exhaustion and reduce luminance dramatically.
- 15) The data on this specification sheet is applicable when TFT-LCD module is placed in landscape position.
- 16) Continuous displaying fixed pattern may induce image sticking. It's recommended to use screen saver or moving content periodically if fixed pattern is displayed on the screen.

2. General Description

G150XG01 V4 is a Color Active Matrix Liquid Crystal Display composed of a TFT-LCD display, a touch sensor glass, a driver circuit, and a backlight system. The screen format is intended to support XGA (1024(H) x 768(V)) screen and 16.2M (RGB 8-bits) or 262k colors (RGB 6-bits). All input signals are LVDS interface compatible. All design rules of this module can correspond to PSWG standard.

G150XG01 V4 is designed for industrial display applications.

2.1 Display Characteristics

The following items are characteristics summary on the table under 25 °C condition:

| Item | Unit | Specifications |
|-----------------------------------------------------------|--------------|-------------------------------------|
| Screen Diagonal | [inch] | 15 |
| Active Area | [mm] | 304.128(H) x 228.096(V) |
| Pixels H x V | | 1024x2, 768x2 (RGBW) |
| Pixel Pitch | [mm] | 0.297 x 0.297 |
| Pixel Arrangement | | R.G.B.W. Rectangle |
| Display Mode | | TN, Normally White |
| Nominal Input Voltage VDD | [Volt] | 3.3 typ. |
| Typical Power Consumption | [Watt] | 9.63 (64 Gray Bar pattern) |
| Weight | [Grams] | 1120g (max.) |
| Physical Size | [mm] | 326.5(H)x 253.5(V) x 15.5(D) (max.) |
| Electrical Interface | | 1 channel LVDS |
| Support Color | | 16.2M / 262K colors |
| Temperature Range Operating Storage (Non-Operating) | [°C] [°C] | -10 to +60 -30 to +85 |
| RoHS Compliance | | RoHS Compliance |

2.2 Touch Characteristics

The following items are characteristics summary on the table under 25 °C condition:

| Item | Unit | Specifications |
|----------------------------------------|--------------|-------------------------------------------------------------|
| Type of Touch Sensor | | Charge-Sensing (Capacitive) Type |
| Panel Size | [mm] | 323.5(W) x 250.5 (H) x 0.7 (T) |
| Sensor Active Area | [mm] | 304.128 (W) x 228.096 (H) |
| Interface | | USB |
| IC Driver (Sensor) | | TangoF32 |
| Channel | [ch] | X:42 Y:31 |
| Surface hardness | [H] | 7 |
| Maximum touch points | | 1 (10mm Cover Lens) 2 (3 mm Cover Lens) |
| Touch Resolution | [ppi] | 3.44 |
| Touch Active Area | [mm] | 304.128 (W) x 228.096 (H) |
| Touch Sensor Pitch | [mm] | 7.256 (W) X 7.378 (H) |
| Touch Method | [mm] | Capacitance sensor |
| Single/Multi-points Accuracy | [mm] | +/-1.5mm |
| Jitter | [mm] | +/- 4mm |
| Offset | [mm] | +/- 1mm |
| The smallest distance between 2 points | [mm] | 2.2mm |
| Sample rate at 10/5/1 point | [Hz] | 60HZ (1 finger) 45HZ (2 finger) |
| Touch sensing height | [mm] | Up to 10mm |
| Interface | | USB |
| TP Controller | | 3TangoF32+ATmega32U2 |
| Number of X / Y Channel | | 42 /31 |
| Resolution X / Y | [Dot] | 21504 / 15872 |
| Support Point | 401. 400. | 1 Finger (10 mm Cover Lens) / 2 Finger (3 mm Cover Lens) |
| Power Consumption | [mWatt] | 91 (typ.) |
| Electrical Interface | | PIXCIR- 500kbps USB Type |
| OS Support | | Win7 / WinXP (Figure 1) |
| Operating Temperature Range | [°C] | -10 to +60 |
| Transparency | [%] | 90 |

Figure 1:

Except Window 7 application, the driver is necessary to be installed before operating. Available drivers are listed as below.

| OS | Kernal | Driver | | Remark |
|-----------------|---------|------------------|-----------------|-----------------------|
| | | USB | | |
| | | Hardware | Software | |
| Windows CE 6.0 | | ARM11 / Cotex-A8 | 6.0 | Note 1 |
| Windows XP | | X86 | SP3 | Note 1 |
| Windows Vista | | X86 | Embedded | Note 1 |
| Windows 7 start | | X86 | Win 7 start | No driver is required |
| Linux | 2.6.28 | X86/ARM | Ubuntu 9.04 | Note 1 |
| | 2.6.31 | X86/ARM | Ubuntu 9.10 | Note 1 |
| | 2.6.32 | X86/ARM | Ubuntu 10.04 | Note 1 |
| | | X86/ARM | Fedora | Note 1 |
| Android | 2.6.29. | ATOM-X86 | Android 1.6-X86 | Support Single Touch |
| | 2.6.29. | ARM9 | Android 2.0/2.1 | Note 1 |
| | 2.6.29. | ARM11 | Android 2.0/2.1 | |

Note 1:

The default code is used for one point touch with 10 mm (thick) vandal glass.

For panels used with 3 mm vandal glass for dual–point touch, a separate code is required to be installed.

2.3 Optical Characteristics

The optical characteristics are measured under stable conditions at 25 °C (Room Temperature):

| Item | Unit | Conditions | Min. | Typ. | Max. | Note |
|---------------------------------------------|----------|--------------------------------------|-------|-------|-------|---------|
| White Luminance | [cd/m2] | 100% Dimming (center point) | 280 | 350 | - | 1 |
| Uniformity | % | 9 Points | 75 | 80 | - | 1, 2, 3 |
| Contrast Ratio | | | 400 | 700 | - | 4 |
| Cross talk | % | | - | 1.2 | 1.5 | 5 |
| Response Time | [msec] | Rising | - | 5.7 | | 6 |
| | [msec] | Falling | - | 2.3 | | |
| | [msec] | Raising + Falling | - | 8 | | |
| Viewing Angle | [degree] | Horizontal (Right) CR = 10 (Left) | 70 | 80 | - | 7 |
| | [degree] | | 70 | 80 | - | |
| | [degree] | Vertical (Upper) CR = 10 (Lower) | 50 | 60 | - | |
| | [degree] | | 70 | 80 | - | |
| Color / Chromaticity Coordinates (CIE 1931) | | Red x | 0.577 | 0.627 | 0.677 | |
| | | Red y | 0.298 | 0.348 | 0.398 | |
| | | Green x | 0.288 | 0.338 | 0.388 | |
| | | Green y | 0.539 | 0.589 | 0.639 | |
| | | Blue x | 0.100 | 0.150 | 0.200 | |
| | | Blue y | 0.029 | 0.079 | 0.129 | |
| | | White x | 0.263 | 0.313 | 0.363 | |
| | | White y | 0.279 | 0.329 | 0.379 | |
| Color Gamut | % | | - | 60 | - | |
| Gamma Value | | | - | 2.2 | - | 8 |

Note 1: Measurement method

Equipment Pattern Generator, Power Supply, Digital Voltmeter, Luminance meter (SR_3 or equivalent)

Aperture 1□with 50cm viewing distance

Test Point Center

Environment < 1 lux

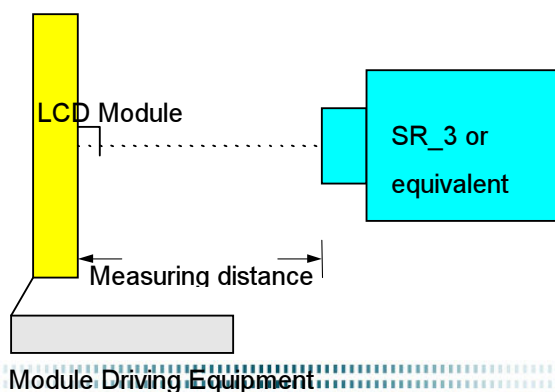

Note 2: Definition of 9 points position (Display active area : 304.128(H) x 228.096(V))

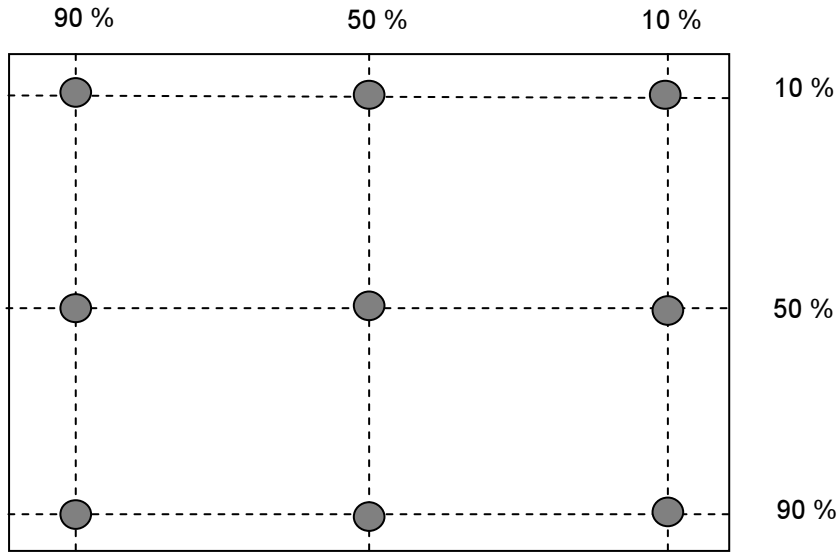

Note 3: The luminance uniformity of 9 points is defined by dividing the minimum luminance values by the maximum test point luminance

$$\delta_{w9} = \frac{\text{Minimum Brightness of nine points}}{\text{Maximum Brightness of nine points}}$$

Note 4 : Definition of contrast ratio (CR):

$$\text{Contrast ratio (CR)} = \frac{\text{Brightness on the "White" state}}{\text{Brightness on the "Black" state}}$$

Note 5 : Definition of cross talk (CT)

$$CT = | YB - YA | / YA \times 100 (\%)$$

Where

YA = Luminance of measured location without gray level 0 pattern (cd/m2)

YB = Luminance of measured location with gray level 0 pattern (cd/m2)

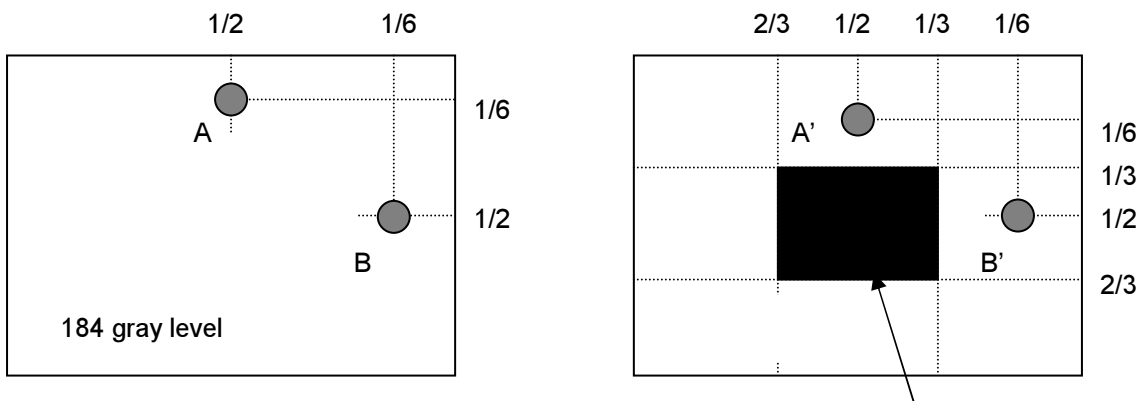

Note 6: Definition of response time:

The output signals of photo detector are measured when the input signals are changed from “White” to “Black” (falling time) and from “Black” to “White” (rising time), respectively. The response time interval is between 10% and 90% of amplitudes. Please refer to the figure as below.

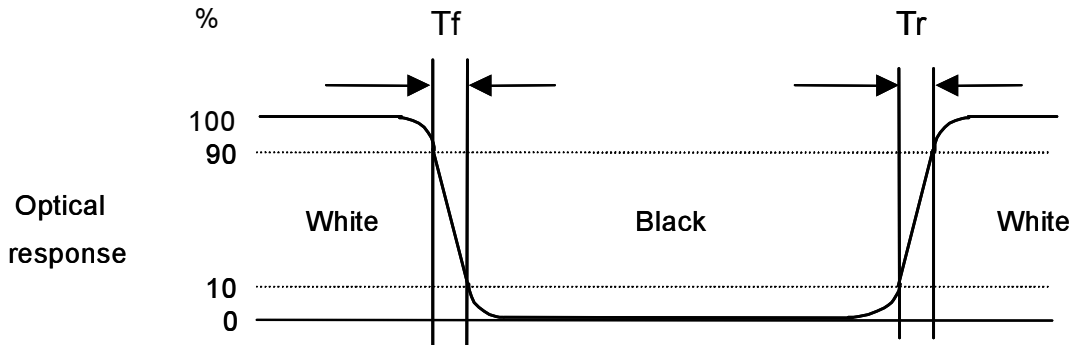

Note 7: Definition of viewing angle

Viewing angle is the measurement of contrast ratio ≥ 10 , at the screen center, over a 180° horizontal and 180° vertical range (off-normal viewing angles). The 180° viewing angle range is broken down as below: 90° (θ) horizontal left and right, and 90° (ϕ) vertical high (up) and low (down). The measurement direction is typically perpendicular to the display surface with the screen rotated to its center to develop the desired measurement viewing angle.

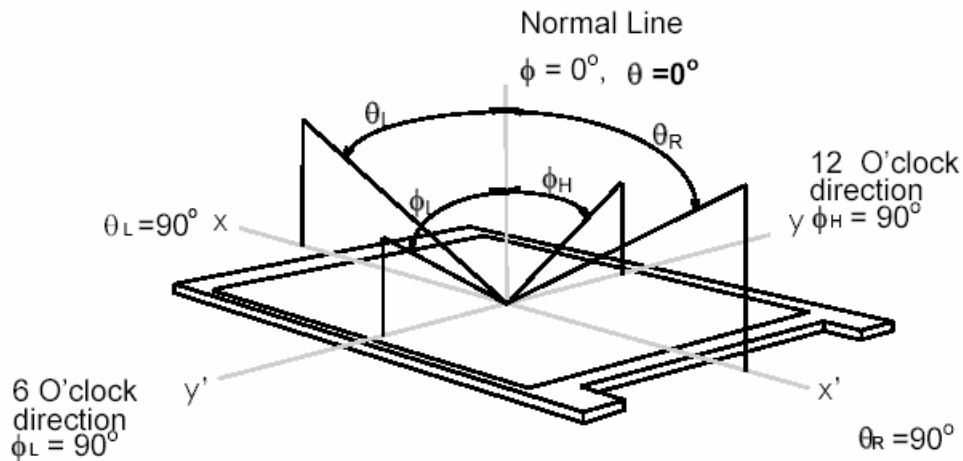

Note 8: Note 8: Definition of Gamma Value

Generally, Gamma Value is defined as the slope of a Gray Level – Luminance curve in log-log space, that is

$$\gamma = d \log(\text{Luminance}) / d \log(\text{Gray Level})$$

The Gamma Value defined in this spec is Linear Regression ($\gamma_1, \gamma_2, \gamma_3, \dots, \gamma_{16}$). γ_1 to γ_{16} are the section gamma of the following 17 sampling points, GL(0), GL(16), GL(32), GL(48), GL(64), GL(80), GL(96), GL(112), GL(128), GL(144), GL(160), GL(176), GL(192), GL(208), GL(224), GL(240) and GL(255), in 8 bits input.

3. Functional Block Diagram

The following diagram shows the functional block of the 15 inch color TFT/LCD module:

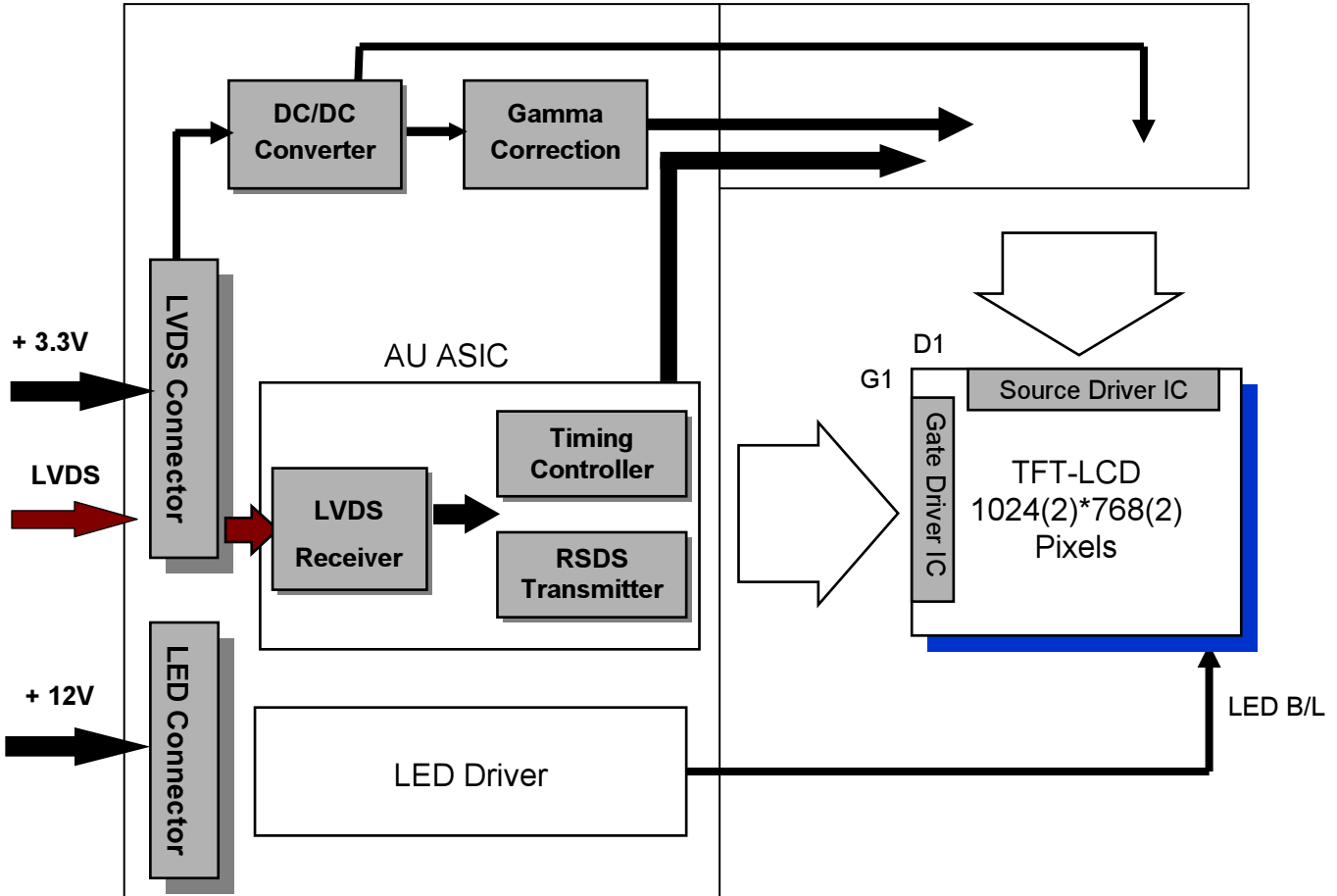

4. Absolute Maximum Ratings

4.1 Absolute Ratings of TFT LCD Module

| Item | Symbol | Min | Max | Unit |
|-------------------------|--------|-------|------|--------|
| Logic/LCD Drive Voltage | Vin | - 0.3 | +3.6 | [Volt] |

4.2 Absolute Ratings of Environment

| Item | Symbol | Min | Max | Unit |
|-----------------------|--------|-----|-----|-------|
| Operating Temperature | TOP | -10 | +60 | [°C] |
| Operation Humidity | HOP | 8 | 90 | [%RH] |
| Storage Temperature | TST | -30 | +85 | [°C] |
| Storage Humidity | HST | 8 | 90 | [%RH] |

Note: Maximum Wet-Bulb should be 39 °C and no condensation.

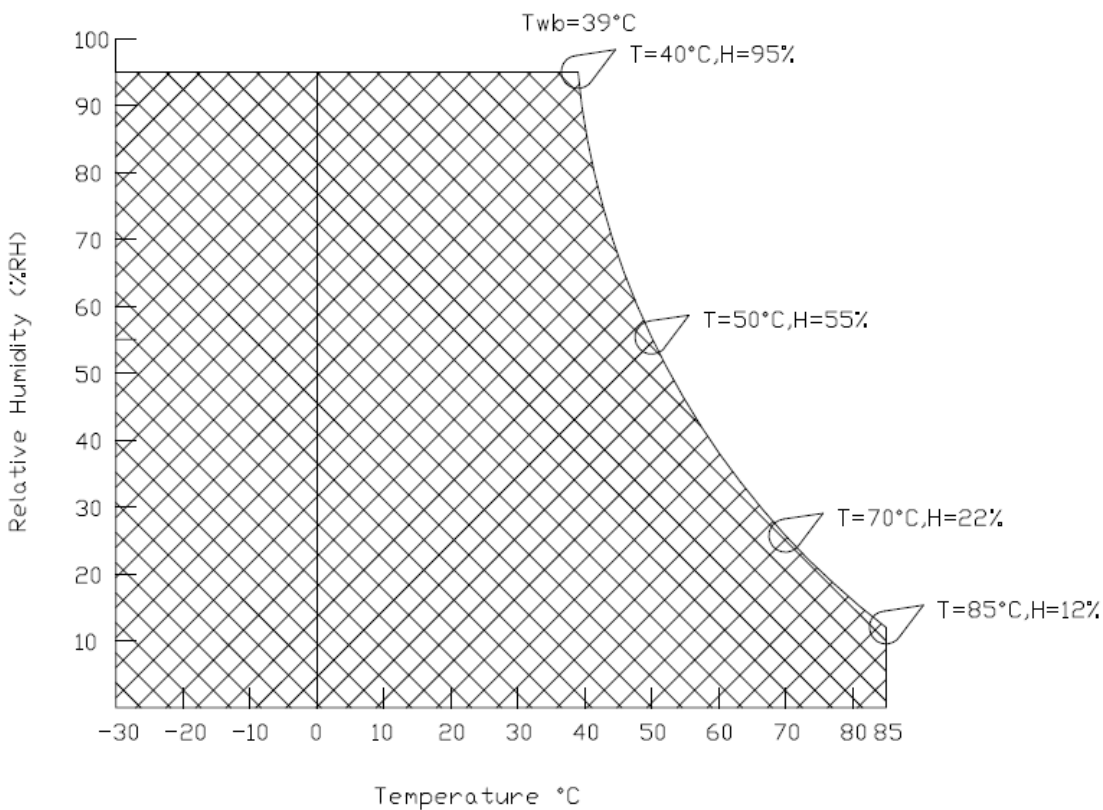

5. Electrical Characteristics

5.1 TFT LCD Module

5.1.1 Power Specification

| Symbol | Parameter | Min | Typ | Max | Units | Remark |
|--------|-------------------------|-----|------|------|--------|--------------------------------------------|
| VDD | Logic/LCD Drive Voltage | 3.0 | 3.3 | 3.6 | [Volt] | ±10% |
| IDD | VDD Current | - | 700 | 840 | [mA] | 64 Gray Bar Pattern (VDD=3.3V, at 60Hz) |
| Irush | LCD Inrush Current | - | - | 3 | [A] | Note 1 |
| PDD | VDD Power | - | 2.31 | 2.77 | [Watt] | 64 Gray Bar Pattern (VDD=3.3V, at 60Hz) |

Note 1: Measurement condition:

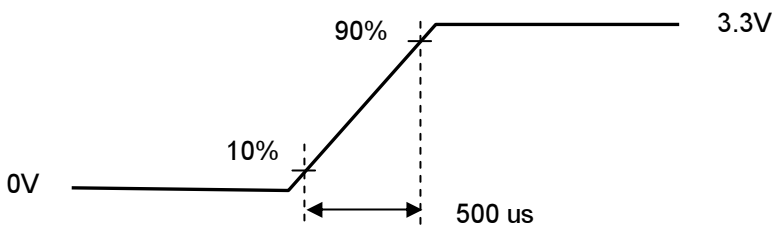
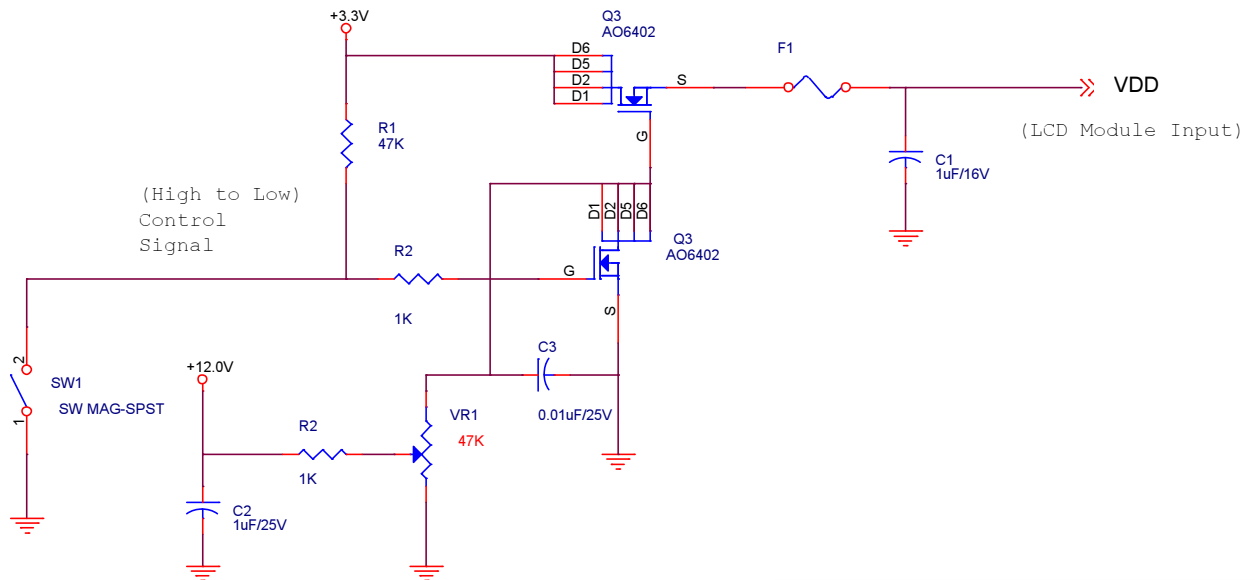

VDD rising time



64 Gray pattern

5.1.2 Signal Electrical Characteristics

Input signals shall be low or Hi-Z state when VDD is off.

| Symbol | Item | Min. | Typ. | Max. | Unit | Remark |
|--------|----------------------------------------|------|------|------|------|----------------|
| VTH | Differential Input High Threshold | - | - | 100 | [mV] | VCM=1.2V |
| VTL | Differential Input Low Threshold | 100 | - | - | [mV] | VCM=1.2V |
| VID | Input Differential Voltage | 100 | 400 | 600 | [mV] | |
| VICM | Differential Input Common Mode Voltage | 1.15 | 1.2 | 1.45 | [V] | VTH/VTL=±100mV |

Note: LVDS Signal Waveform.

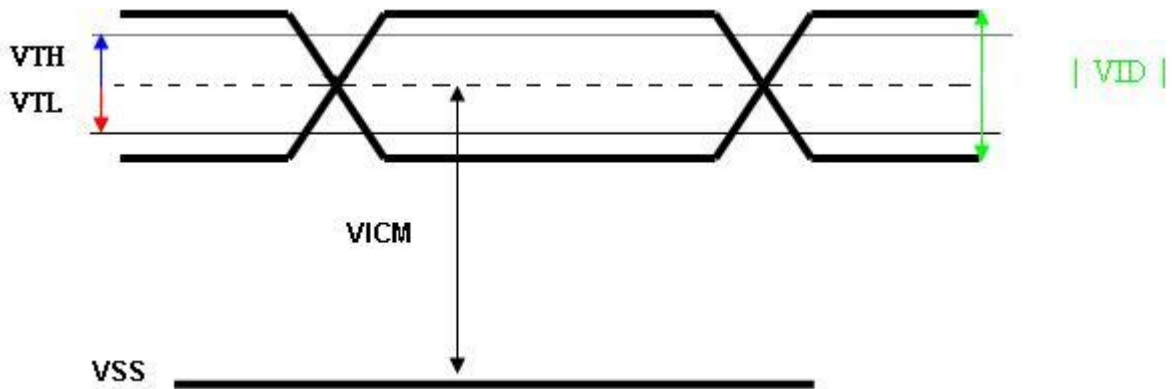

5.2 Backlight Unit

5.2.1 Parameter guideline for LED

Following characteristics are measured under stable condition using a LED driving board at 25 °C (Room Temperature).

| Symbol | Parameter | Min | Typ | Max | Unit | Remark |
|---------------------|------------------------|-------|------|------|------|---------------------|
| V _{cc} | Input Voltage | 10.8 | 12 | 12.6 | Volt | |
| I _{vcc} | Input Current | - | 0.61 | - | A | 100% Dimming |
| P _{LED} | Power Consumption | - | 7.32 | 10 | Watt | 100% Dimming |
| F _{PWM} | PWM Dimming Frequency | 200 | - | 20k | Hz | |
| | Swing Voltage | 4.5 | 5 | 5.5 | | |
| | Dimming Duty Cycle | 5 | - | 100 | % | |
| V _{analog} | Analog Dimming Voltage | 2.0 | 5 | 5.5 | | 5V, 100% Brightness |
| I _F | LED Forward Current | - | 80 | 84 | mA | Ta = 25°C |
| Operating Life | | 50000 | - | - | Hrs | Ta = 25°C |

Note 1: Ta means ambient temperature of TFT-LCD module.

Note 2: If G150XG01 V4 module is driven at high ambient temperature & humidity condition. The operating life will be reduced.

Note 3: Operating life means brightness goes down to 50% initial brightness. Min. operating life time is estimated data.

5.3 Touch Unit

5.3.1 Touch Electrical Specification

| Symbol | Parameter | Min | Typ | Max | Units | Remark |
|-----------------|----------------------------|------|-----|------|--------|------------------------|
| V _{DD} | Touch/ Logic Drive Voltage | 4.75 | 5 | 5.25 | [Volt] | ±5% |
| VID | Input Differential Voltage | | 400 | | [mV] | Hi-Speed mode; USB 2.0 |

6. Signal Characteristic

6.1 Pixel Format Image

Following figure shows the relationship between input signal and LCD pixel format.

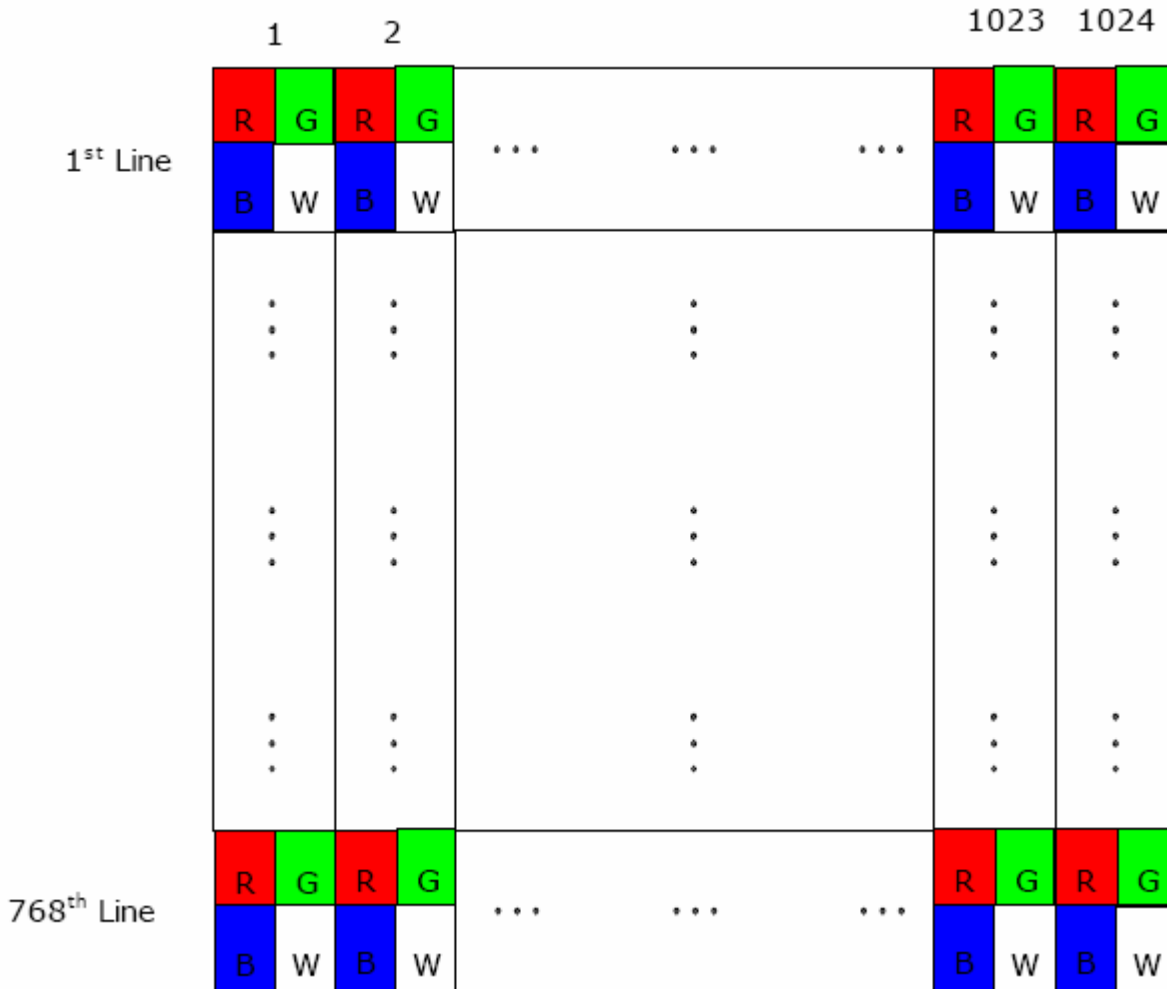

6.2 Scanning Direction

The following figures show the image seen from the front view. The arrow indicates the direction of scan.

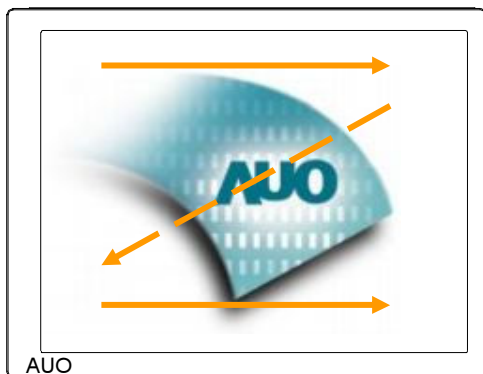

Fig. 1 Normal scan (Pin4, REV = Low or NC)

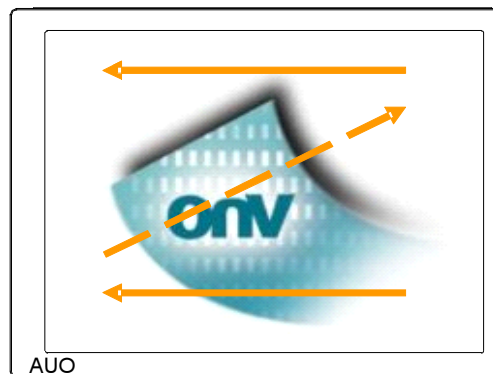

Fig. 2 Reverse scan (Pin4, REV = High)

6.3 Signal Description

The module using a pair of LVDS receiver SN75LVDS82(Texas Instruments) or compatible. LVDS is a differential signal technology for LCD interface and high speed data transfer device. Transmitter shall be SN75LVDS83(negative edge sampling) or compatible. The first LVDS port(RxOxxx) transmits odd pixels while the second LVDS port(RxExxx) transmits even pixels.

| Input Signal Interface | | |
|------------------------|--------|---------------------------------------------------------------------------|
| Pin No. | Symbol | Description |
| 1 | VDD | Power Supply, 3.3V (typical) |
| 2 | VDD | Power Supply, 3.3V (typical) |
| 3 | GND | Ground |
| 4 | REV | Reverse Scan [H: Enable; L/NC: Disable]*Note1,3 |
| 5 | Rin0- | - LVDS differential data input |
| 6 | Rin0+ | + LVDS differential data input |
| 7 | GND | Ground |
| 8 | Rin1- | - LVDS differential data input |
| 9 | Rin1+ | + LVDS differential data input |
| 10 | GND | Ground |
| 11 | Rin2- | - LVDS differential data input |
| 12 | Rin2+ | + LVDS differential data input |
| 13 | GND | Ground |
| 14 | ClkIN- | - LVDS differential clock input |
| 15 | ClkIN+ | + LVDS differential clock input |
| 16 | GND | Ground |
| 17 | Rin3- | - LVDS differential data input *Note2 |
| 18 | Rin3+ | + LVDS differential data input *Note2 |
| 19 | NC/GND | Reserved for AUO internal test. Please set it as NC or Ground. |
| 20 | SEL68 | Selection for 6 bits/8bits LVDS data input[H/NC: 6bits, L: 8bits]*Note1,3 |

Note 1: Input signals shall be in low status when VDD is off.

Note 2: For 6 bits input mode, pin 17 and pin 18 must be floated.

Note 3: High stands for “3.3V”, Low stands for “0V”, NC stands for “No Connection”.

6.4 The Input Data Format

6.4.1 SEL68

SEL68 = "High" or "NC" for 6 bits LVDS Input

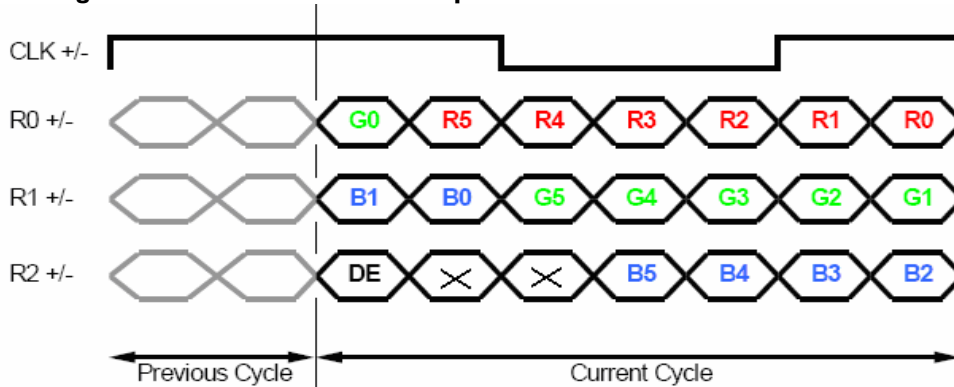

SEL68 = "Low" for 8 bits LVDS Input

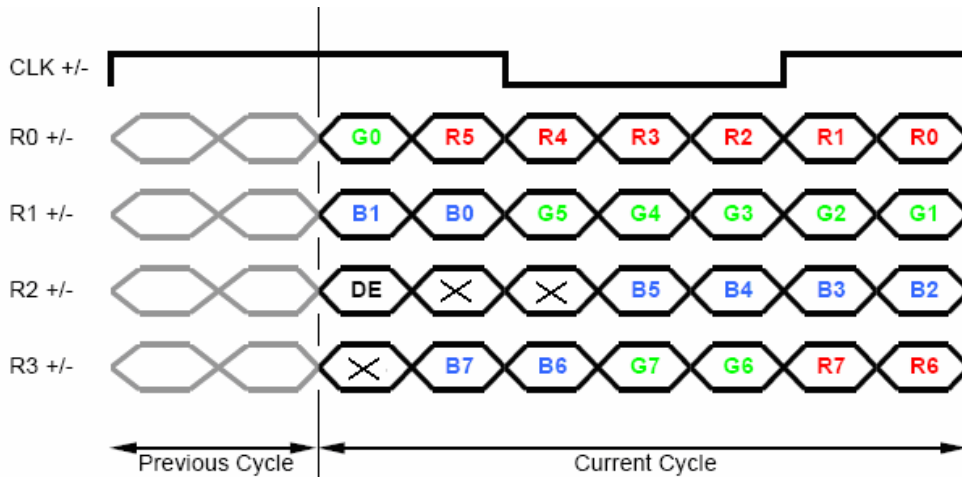

| Signal Name | Description | Remark |
|-------------|--------------|--------------------------------------------------------------------------------------------------------------------|
| R7 | Red Data 7 | Red-pixel Data For 6Bits LVDS input MSB: R5 ; LSB: R0 For 8Bits LVDS input MSB: R7 ; LSB: R0 |
| R6 | Red Data 6 | |
| R5 | Red Data 5 | |
| R4 | Red Data 4 | |
| R3 | Red Data 3 | |
| R2 | Red Data 2 | |
| R1 | Red Data 1 | |
| R0 | Red Data 0 | |
| G7 | Green Data 7 | Green-pixel Data For 6Bits LVDS input MSB: G5 ; LSB: G0 For 8Bits LVDS input MSB: G7 ; LSB: G0 |
| G6 | Green Data 6 | |
| G5 | Green Data 5 | |
| G4 | Green Data 4 | |
| G3 | Green Data 3 | |
| G2 | Green Data 2 | |
| G1 | Green Data 1 | |
| G0 | Green Data 0 | |

| | | |
|----------------------------------------------|----------------------------------------------------------------------------------------------------------------------|---------------------------------------------------------------------------------------------------------------------------------------------------------------------------|
| B7 B6 B5 B4 B3 B2 B1 B0 | Blue Data 7 Blue Data 6 Blue Data 5 Blue Data 4 Blue Data 3 Blue Data 2 Blue Data 1 Blue Data 0 | Blue-pixel Data For 6Bits LVDS input MSB: B5 ; LSB: B0 For 8Bits LVDS input MSB: B7 ; LSB: B0 |
| RxCLKIN | LVDS Data Clock | The typical frequency is 65MHz. The signal is used to strobe the pixel data and DE signals. All pixel data shall be valid at the falling edge when the DE signal is high. |
| DE | Data Enable Signal | When the signal is high, the pixel data shall be valid to be displayed. |

Note: Output signals from any system shall be low or Hi-Z state when VDD is off.

AUO Confidential For JUNGLIM Internal Use Only / 2011/4/25

6.5 Interface Timing

6.5.1 Timing Characteristics

| Signal | Parameter | Symbol | Min. | Typ. | Max. | Unit | |
|--------------|--------------------|---------------|----------|------|------|------|-------------|
| Clock Timing | Clock frequency | $1/T_{Clock}$ | 50 | 65 | 80 | MHz | |
| Vsync Timing | Vertical Section | Period | T_V | 776 | 806 | 1023 | T_{Line} |
| | | Active | T_{VD} | - | 768 | - | |
| | | Blanking | T_{VB} | 8 | 38 | 255 | |
| Hsync Timing | Horizontal Section | Period | T_H | 1074 | 1344 | 2047 | T_{Clock} |
| | | Active | T_{HD} | - | 1024 | - | |
| | | Blanking | T_{HB} | 50 | 320 | 1023 | |
| Frame Rate | | F | 50 | 60 | 75 | Hz | |

Note: DE mode only.

Note : Typical value refer to VESA STANDARD

6.5.2 Input Timing Diagram

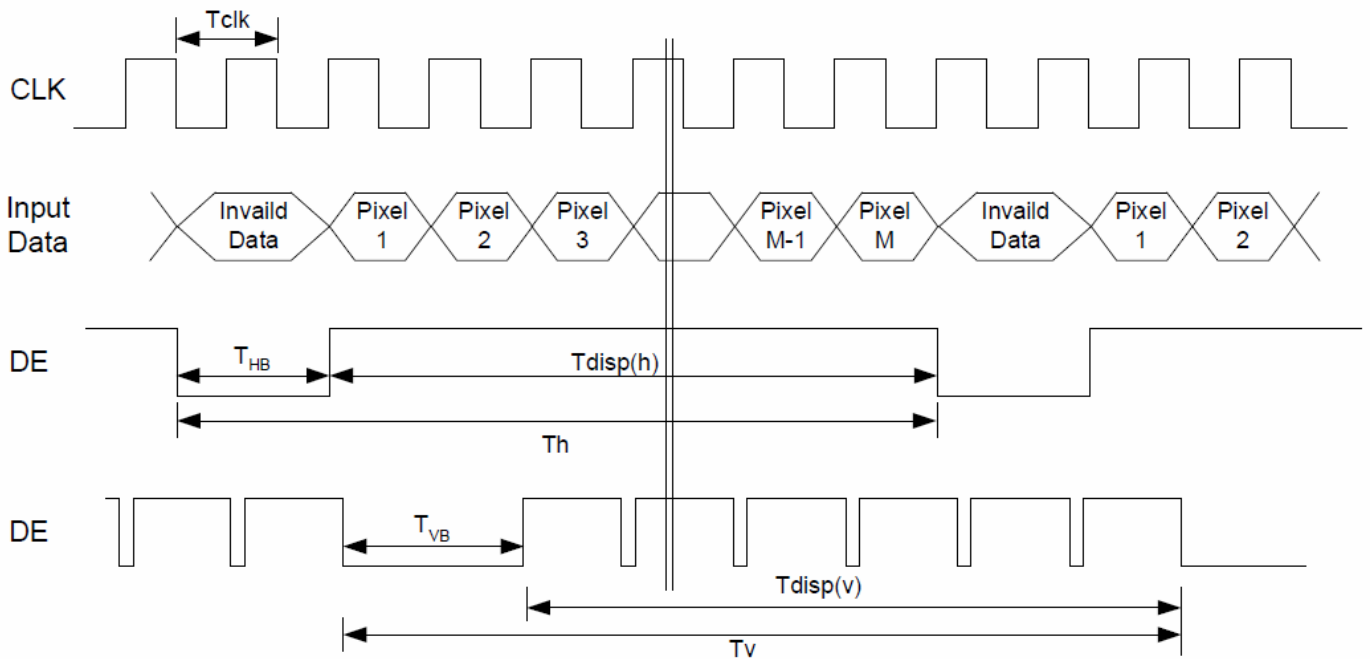

6.6 Power ON/OFF Sequence

VDD power and LED on/off sequence is as below. Interface signals are also shown in the chart. Signals from any system shall be Hi-Z state or low level when VDD is off.

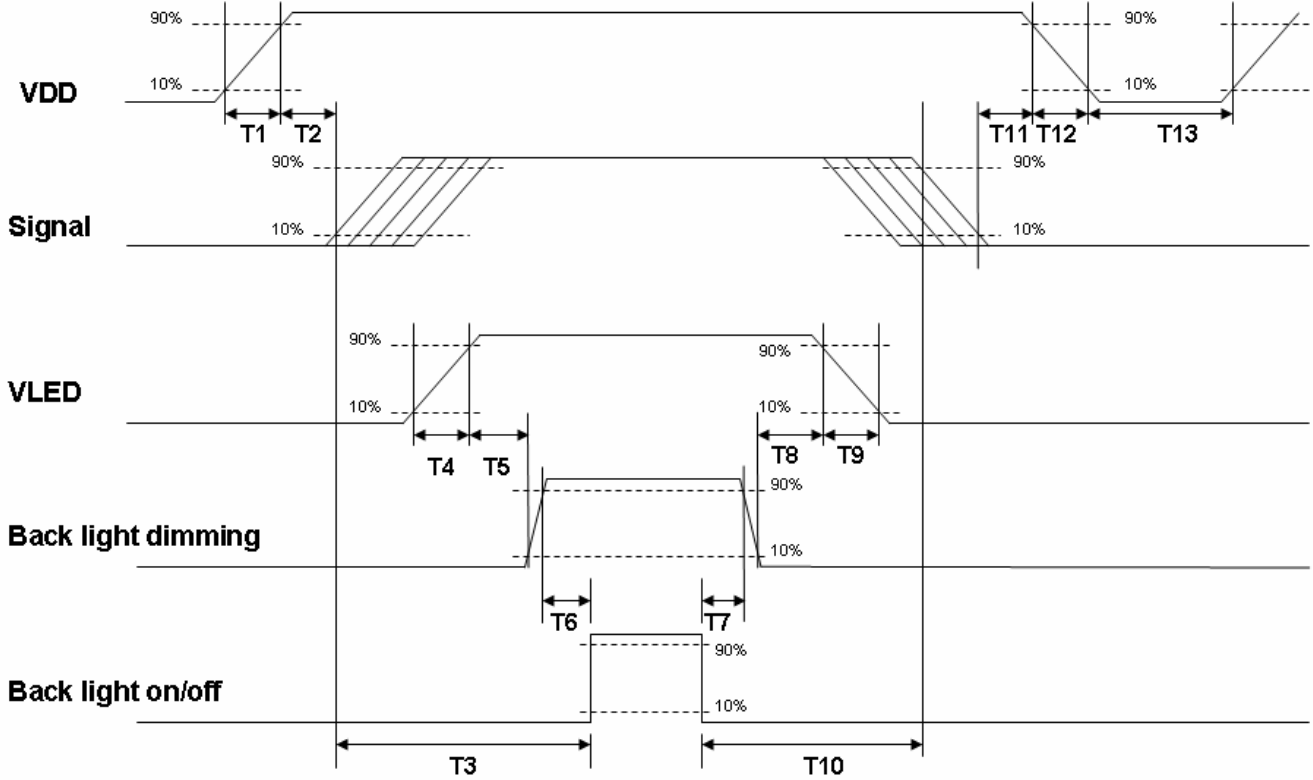

Power ON/OFF sequence timing

| Parameter | Value | | | Units |
|-----------|-------|------|------|-------|
| | Min. | Typ. | Max. | |
| T1 | 0.5 | - | 10 | [ms] |
| T2 | 30 | 40 | 50 | [ms] |
| T3 | 200 | - | - | [ms] |
| T4 | 0.5 | - | 10 | [ms] |
| T5 | 10 | - | - | [ms] |
| T6 | 10 | - | - | [ms] |
| T7 | 0 | - | - | [ms] |
| T8 | 10 | - | - | [ms] |
| T9 | - | - | 10 | [ms] |
| T10 | 110 | - | - | [ms] |
| T11 | 0 | 16 | 50 | [ms] |
| T12 | - | - | 10 | [ms] |
| T13 | 1000 | - | - | [ms] |

The above on/off sequence should be applied to avoid abnormal function in the display. Please make sure to turn off



the power when you plug the cable into the input connector or pull the cable out of the connector.

7. Connector & Pin Assignment

Physical interface is described as for the connector on module. These connectors are capable of accommodating the following signals and will be following components.

7.1 TFT-LCD Signal: LVDS Interface Connector

| Connector Name / Designation | Signal Connector |
|------------------------------|-----------------------|
| Manufacturer | STM or compatible |
| Connector Model Number | MSB240420-E |
| Mating Housing Part Number | P240420 or compatible |

| Pin# | Signal Name | Pin# | Signal Name |
|------|-------------|------|-------------|
| 1 | VDD | 2 | VDD |
| 3 | GND | 4 | REV |
| 5 | Rin0- | 6 | Rin0+ |
| 7 | GND | 8 | Rin1- |
| 9 | Rin1+ | 10 | GND |
| 11 | Rin2- | 12 | Rin2+ |
| 13 | GND | 14 | ClkIN- |
| 15 | ClkIN+ | 16 | GND |
| 17 | Rin3- | 18 | Rin3+ |
| 19 | NC/GND | 20 | SEL68 |

7.1.1 Connector Illustration

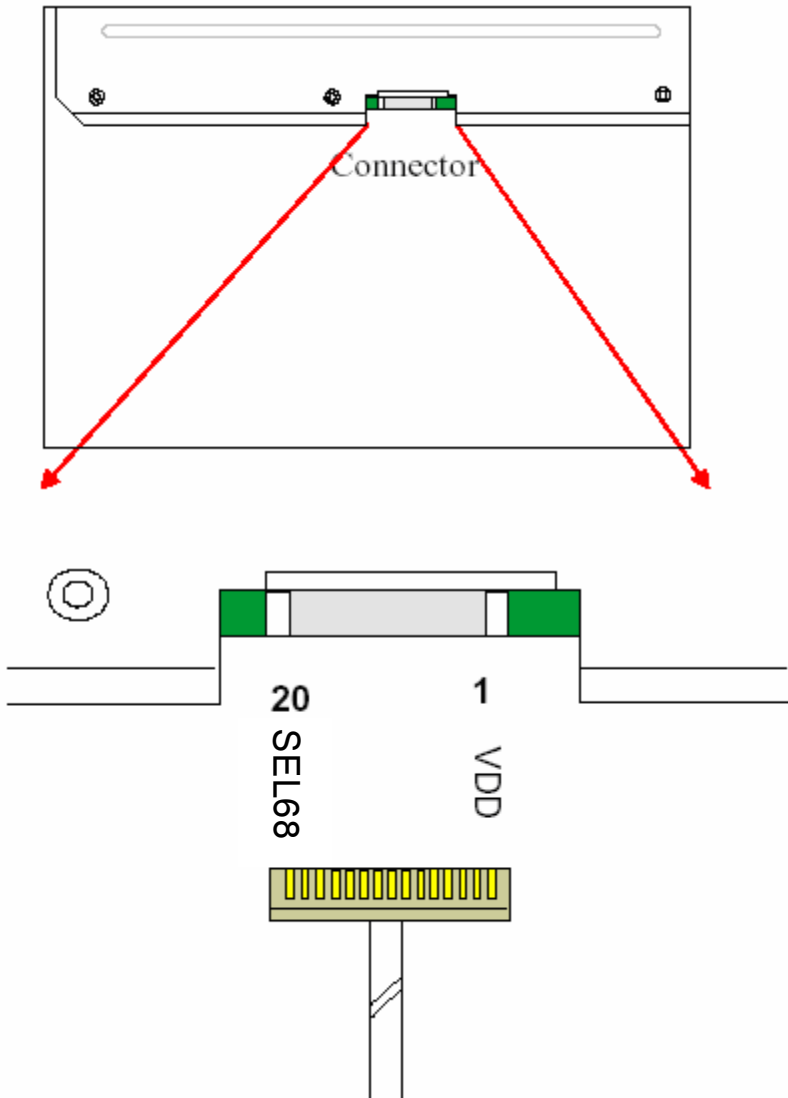

7.2 LED Backlight Unit:

LED Driver Connector

| | |
|-------------------------------------|------------------------------|
| Connector Name / Designation | LED Connector |
| Manufacturer | E&T or compatible |
| Connector Model Number | 3808K-F05N-02R or compatible |
| Mating Connector Model Number | H208K-P05N-02B or compatible |

LED Driver Connector Pin Assignment

| Pin# | Symbol | Signal Name |
|------|---------|-------------------------------|
| 1 | Vcc | 12V |
| 2 | GND | GND |
| 3 | Enable | 5V-On / 0V-Off |
| 4 | Dimming | PWM Dimming or Analog Dimming |
| 5 | NC | NC |

7.3 Touch Unit:

Touch Driver Connector

| | |
|-------------------------------------|-------------------------|
| Connector Name / Designation | For TP Connector |
| Manufacturer | Hirose |
| Type / Part Number | DF13A-4P-1.25H |
| Mating Connector / Part Number | DF13-4S-1.25C |

Touch Driver Connector Pin Assignment

| Pin# | Symbol | Signal Name |
|------|--------|------------------------------------------------------|
| 1 | GND | GND |
| 2 | +Data | D-USB Full Speed Positive Data Upstream Port / CLOCK |
| 3 | -Data | D-USB Full Speed Negative Data Upstream Port / DATA |
| 4 | Vin | Positive voltage to connection PC USB +5V pin |

8. Reliability Test Criteria

| Items | Required Condition | Note |
|--------------------------------|-----------------------------------------------------------------------------------------------------------------------------------------------|--------|
| Temperature Humidity Bias | 50°C/80%,300 hours | |
| High Temperature Operation | 60 °C,300 hours | |
| Low Temperature Operation | -10 °C,300 hours | |
| Hot Storage | 85°C, 300 hours | |
| Cold Storage | -30 °C,300 hours | |
| Thermal Shock Test | -10 °C/30 min ,60 °C /30 min ,100cycles | |
| Shock Test (Non-Operating) | 50G,20ms,Half-sine wave,(±X, ±Y, ±Z) | |
| Vibration Test (Non-Operating) | 1.5G, (10~200Hz, P-P) 30 mins/axis (X, Y, Z) | |
| On/off test | On/10 sec, Off/10 sec, 30,000 cycles | |
| ESD | Contact Discharge: ± 8KV, 150pF(330Ω) 1sec, 8 points, 25 times/ point Air Discharge: ± 15KV, 150pF(330Ω) 1sec, 8 points, 25 times/ point | Note 1 |

Note1: According to EN61000-4-2, ESD class B: Some performance degradation allowed. No data lost
 . Self-recoverable. No hardware failures.

9. Mechanical Characteristics

9.1 LCM Outline Dimension (Front View)

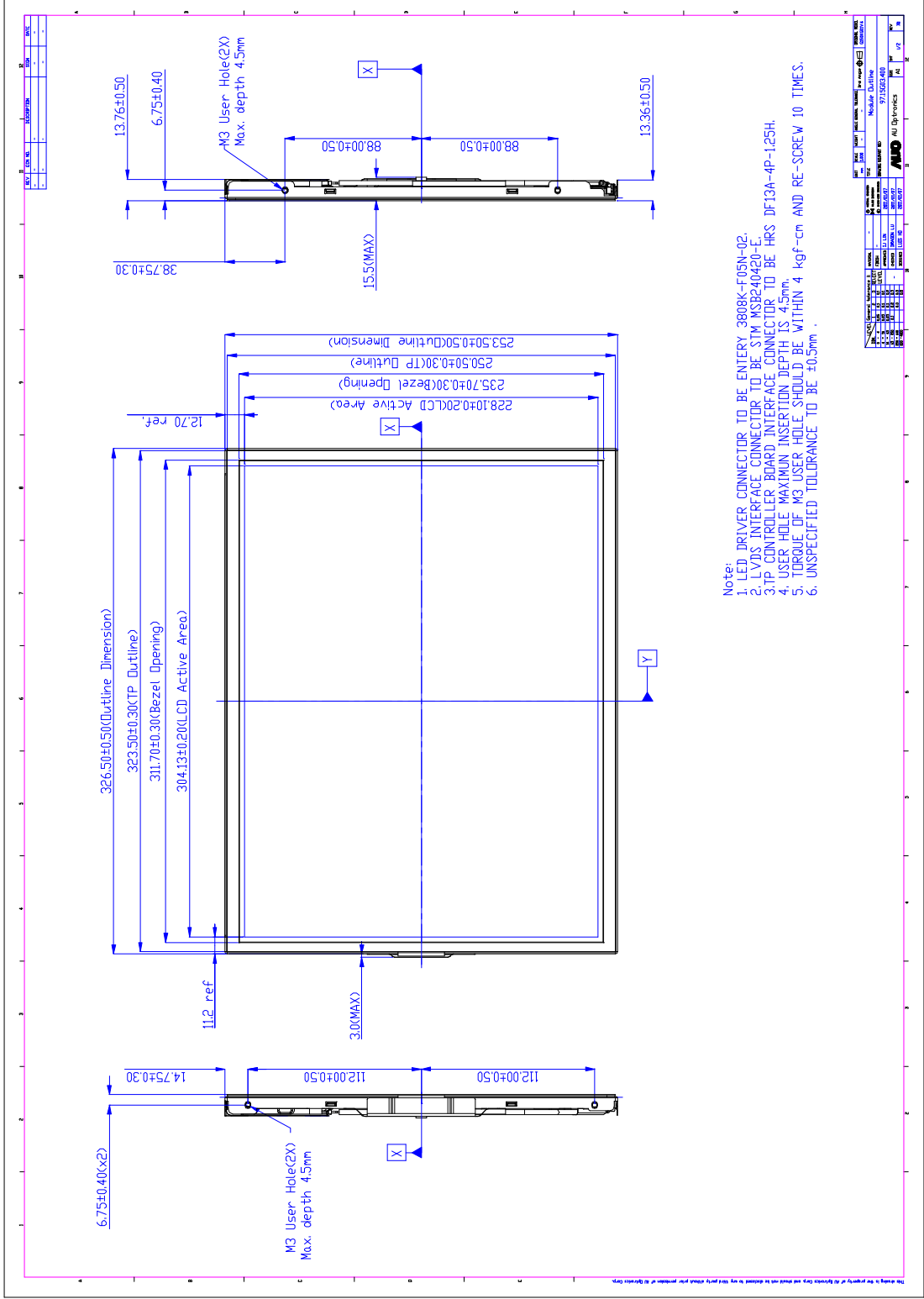

9.2 LCM Outline Dimension (Rear View)

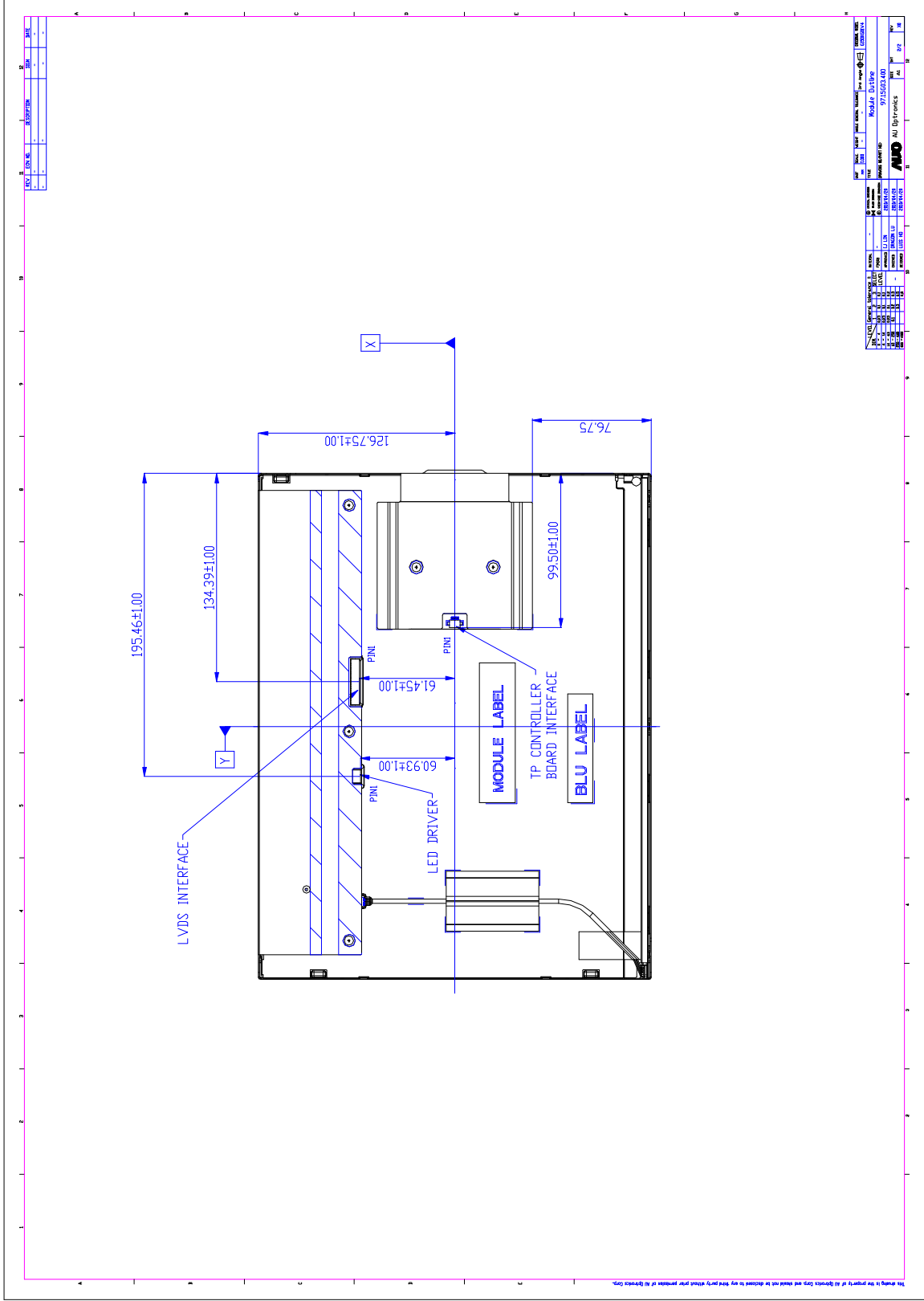

10. Label and Packaging

10.1 Shipping Label (on the rear side of TFT-LCD display)

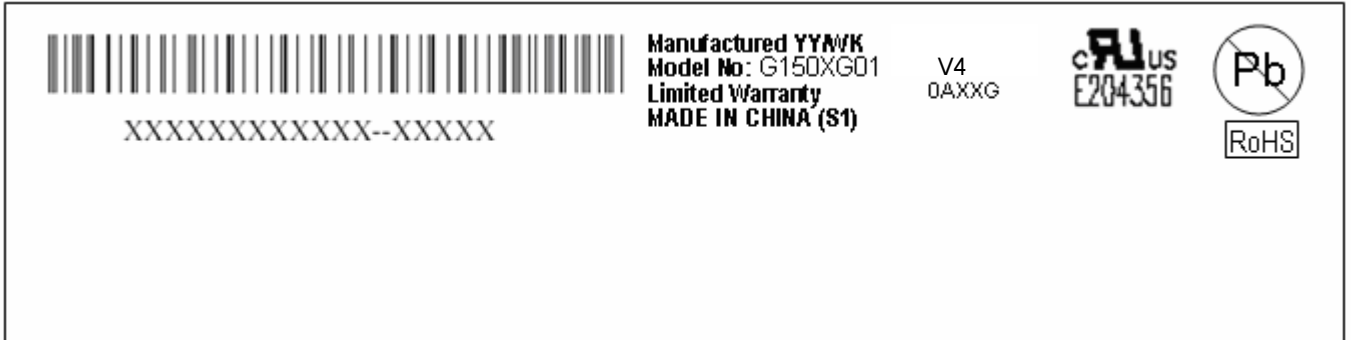

10.2 Carton Package

Max capacity: 12pcs TFT-LCD module per carton

Max weight: 22 kg per carton

Outside dimension of carton: 375(L)mm* 430(W)mm* 353(H)mm

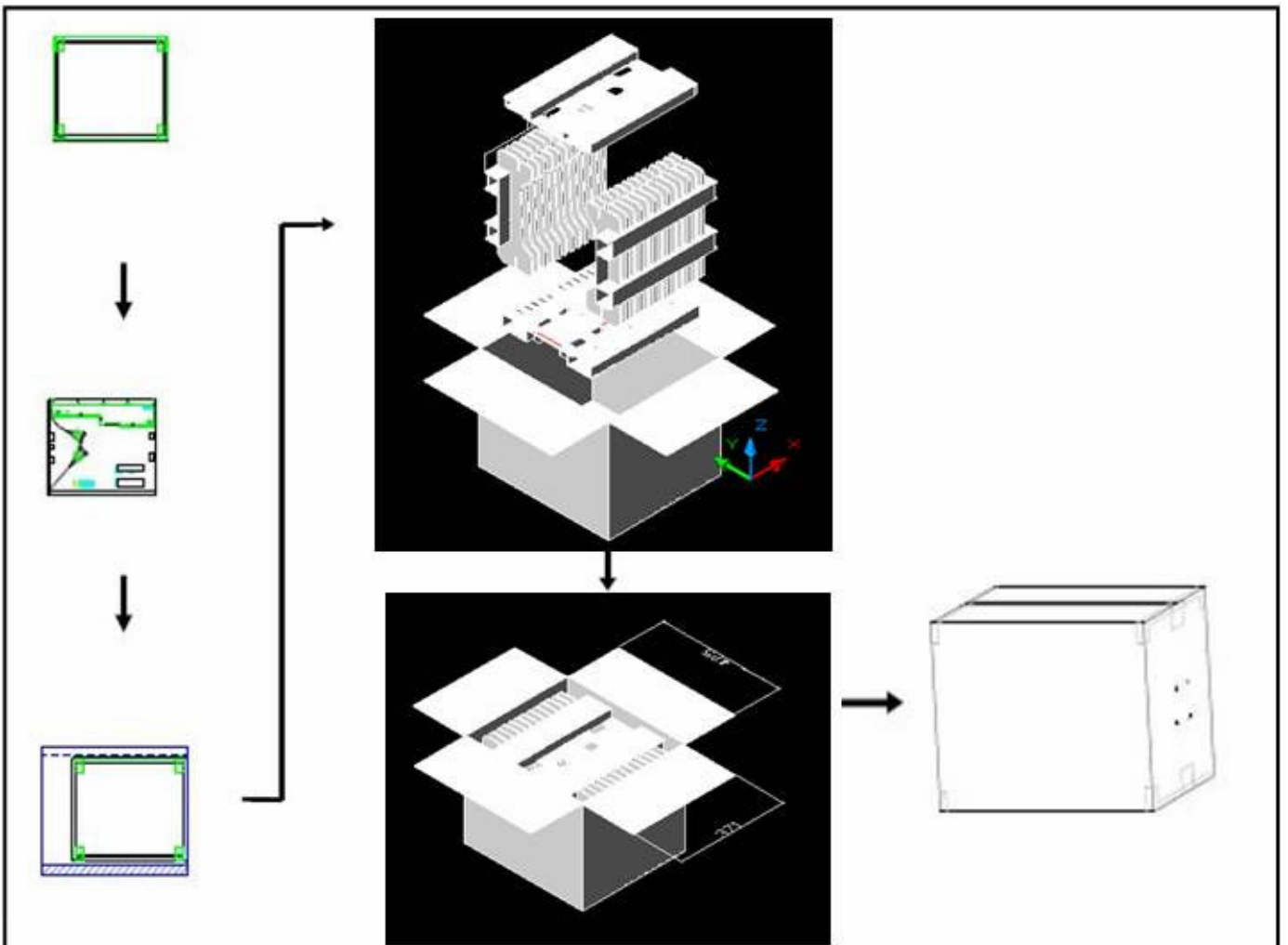

11 Safety

11.1 Sharp Edge Requirements

There will be no sharp edges or comers on the display assembly that could cause injury.

11.2 Materials

11.2.1 Toxicity

There will be no carcinogenic materials used anywhere in the display module. If toxic materials are used, they will be reviewed and approved by the responsible AUO toxicologist.

11.2.2 Flammability

All components including electrical components that do not meet the flammability grade UL94-V1 in the module will complete the flammability rating exception approval process.

The printed circuit board will be made from material rated 94-V1 or better. The actual UL flammability rating will be printed on the printed circuit board.

11.3 Capacitors

If any polarized capacitors are used in the display assembly, provisions will be made to keep them from being inserted backwards.

11.4 National Test Lab Requirement

The display module will satisfy all requirements for compliance to:

UL 1950, First Edition

U.S.A. Information Technology Equipment