



GlobalTop Technology Inc.

LadyBird-3

GPS Module

Data Sheet(Tape Reel)

Part Number: PA6C

Revision: V0E



The LadyBird-3 is a 4<sup>th</sup> generation GPS antenna module with lightning fast TTFF, ultra high sensitivity (-165dBm), and low power consumption in a small form factor (16\*16\*6.2mm)

This document is the exclusive property of GlobalTop Tech Inc. and should not be distributed, reproduced, into any other format without prior permission of GlobalTop Tech Inc. Specifications subject to change without prior notice.

**Copyright © 2011 GlobalTop Technology Inc. All Rights Reserved.**

No.16 Nan-ke 9<sup>th</sup> Rd, Science-Based Industrial Park, Tainan, 741, Taiwan, R.O.C.

Tel: +886-6-5051268 / Fax: +886-6-5053381 / Email: [sales@gtop-tech.com](mailto:sales@gtop-tech.com) / Web: [www.gtop-tech.com](http://www.gtop-tech.com)



## Version History

<b>Title:</b>	<b>GlobalTop LadyBird-3 Datasheet(Tape Reel)</b>		
<b>Subtitle:</b>	<b>GPS Module</b>		
<b>Doc Type:</b>	<b>Datasheet</b>		
<b>Revision</b>	<b>Date</b>	<b>Author</b>	<b>Description</b>
V0A	2013-03-08	Yingjie	First Release
V0B	2013-07-30	Delano	Revise 6VDC to 4.3VDC The chapter 1.8 AlwaysLocate™ update Remove GAGAN and Standalone words
V0C	2013-09-24	Yingjie	Modify 5.2 Tape Reel Packing
V0D	2013-11-19	Dylan	Revise ±10ns jitter to ±10ns RMS jitter Add Power Saving Current Update GSV-GNSS Satellites in View
V0E	2013-12-31	Dylan	Add 1.7 EASY™ description



## Table of Contents

<b>1. Functional Description</b> .....	<b>4</b>
1.1 Overview .....	4
1.2 Highlights and Features .....	5
1.3 System Block Diagram .....	6
1.4 Multi-tone active interference canceller .....	7
1.5 1PPS .....	7
1.6 AGPS Support for Fast TTFF (EPO in flash™) .....	7
1.7 EASY™ .....	7
1.8 AlwaysLocate™ (Advance Power Periodic Mode) .....	9
1.9 LOCUS (Embedded Logger Function) .....	9
<b>2. Specifications</b> .....	<b>10</b>
2.1 Mechanical Dimension .....	10
2.2 Recommended PCB pad Layout .....	11
2.3 Pin Configuration .....	12
2.4 Pin Assignment .....	12
2.5 Description of I/O Pin .....	13
2.6 Specification .....	15
2.7 Absolute Maximum Ratings .....	16
2.8 Operating Conditions .....	16
<b>3. Protocols</b> .....	<b>17</b>
3.1 NMEA Output Sentences .....	17
3.2 MTK NMEA Command Protocols .....	23
3.3 Firmware Customization Services .....	23
<b>4. Reference Design</b> .....	<b>24</b>
4.1 Reference Design Circuit .....	24
<b>5. Packing and Handling</b> .....	<b>25</b>
5.1 Moisture Sensitivity .....	25
5.2 Tape Reel Packing Information .....	26
5.3 Storage and Floor Life Guideline .....	30
5.4 Drying .....	30
5.5 ESD Handling .....	31
<b>6. Reflow Soldering Temperature Profile</b> .....	<b>32</b>
6.1 SMT Reflow Soldering Temperature Profile .....	32
6.2 Manual Soldering .....	36
<b>7. Contact Information</b> .....	<b>36</b>

# 1. Functional Description

## 1.1 Overview

GlobalTopLadyBird-3 is an ultra-compact patch-on-top GPS receiver module. LadyBird-3 is built based on the MediaTek new generation GPS Chipset MT3339 capable of achieving the industry's highest level of sensitivity (-165dBm) and instant Time-to-First Fix (TTFF). It is designed for lowest power consumption for precise GPS signal processing while giving the ultra-precise positioning under low receptive, high velocity conditions.

LadyBird-3 supports up to 210 PRN channels with 66 search channels and 22 simultaneous tracking channels. With SBAS ranging (WAAS, EGNOS, GAGAN\*, and MSAS), QZSS and AGPS, LadyBird-3 can provide even more accurate positioning. The ISSCC2011 awarded **12-Multi-Tone Active Interference Canceller** is capable of removing 12 active noise sources enables customer to have more flexibility in system design.

LadyBird-3 is excellent in low power consumption (acquisition 82mW, tracking 66mW) suitable for power sensitive devices especially portable applications.

\*GAGAN will later be supported.

### Application:

- ✓ Handheld Device
- ✓ Tablet PC/PLB/MID
- ✓ M2M application
- ✓ Asset management
- ✓ Surveillance



## 1.2 Highlights and Features

- ◆ Built-in 15X15X4mm ceramic patch antenna on the top of the module
- ◆ Ultra-High Sensitivity: -165dBm(w/o patch antenna), up to 45dB C/N of SVs in open sky reception
- ◆ High Update Rate: up to 10Hz<sup>(Note1)</sup>
- ◆ 12 multi-tone active interference canceller<sup>(Note2)</sup>[ISSCC 2011 Award -Section 26.5]  
([http://isscc.org/doc/2011/isscc2011.advanceprogrambooklet\\_abstracts.pdf](http://isscc.org/doc/2011/isscc2011.advanceprogrambooklet_abstracts.pdf))
- ◆ High 1-PPS timing accuracy for Timing Applications ( $\pm 10$ ns RMS jitter)
- ◆ AGPS Support for Fast TTFF (EPO in flash<sup>TM</sup> Enable 7 days/14 days)
- ◆ EASY<sup>TM</sup>(Note2): Self-Generated Orbit Prediction for instant positioning fix
- ◆ AlwaysLocate<sup>TM</sup>(Note2) Intelligent Algorithm (Advance Power Periodic Mode) for power saving
- ◆ LOCUS (Embedded Logger Function)<sup>(Note3)</sup>
- ◆ GlobalTop Firmware Customization Services
- ◆ Current Consumption (@3.3V):
  - Acquisition: 25mA Typical
  - Tracking: 20mA Typical
- ◆ E911, RoHS, REACH compliant
- ◆ CE, FCC Certification

<sup>(Note1)</sup>: SBAS can only be enabled when update rate is equal or less than to 5Hz.

<sup>(Note2)</sup>: Some features need special firmware or command programmed by customer, please refer to "PMTK Command List"

<sup>(Note3)</sup>: Please refer to "GlobalTop LOCUS Library User Manual"

### 1.3 System Block Diagram

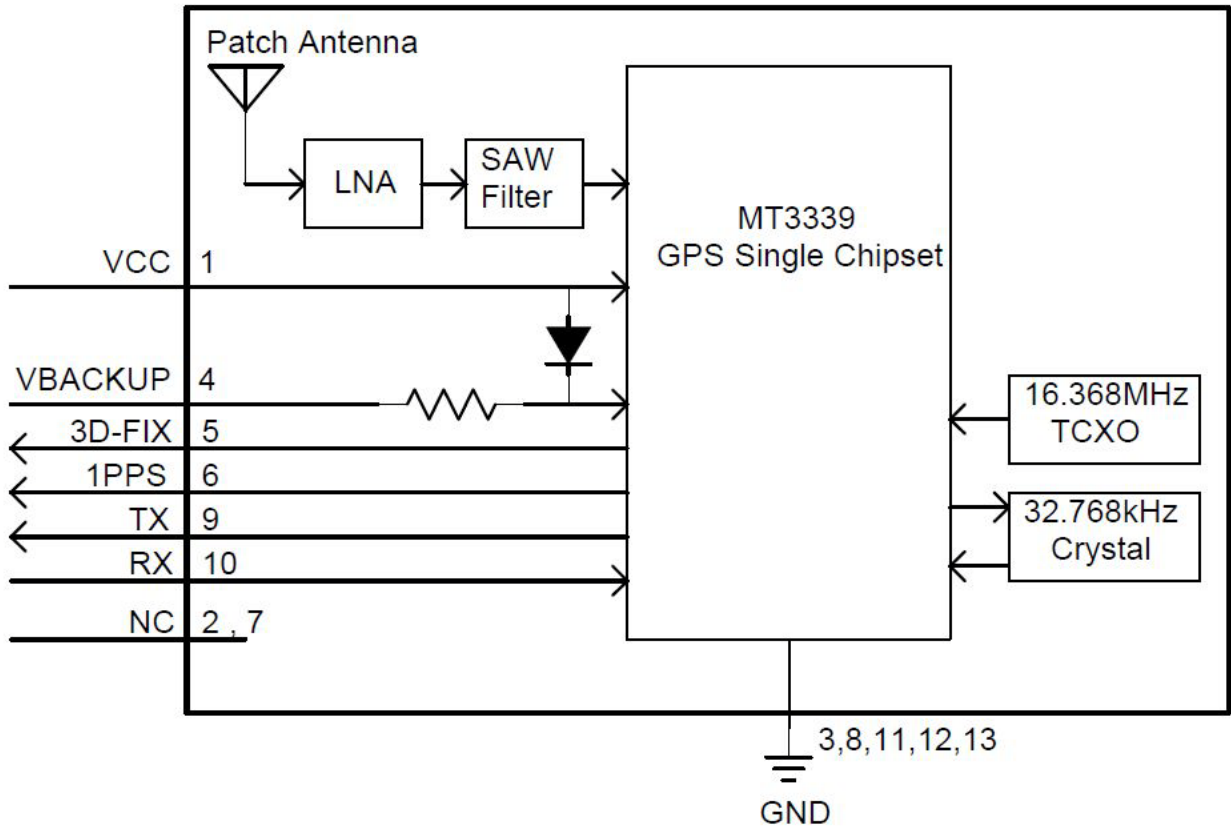

## 1.4 Multi-tone active interference canceller

Navigation system often integrated with variant applications that are not limited to Wi-Fi, GSM/GPRS, 3G/4G, Bluetooth. Such system, as often seen, generates RF harmonics which would influence the GPS reception and performance. The embedded multi-tone active interference canceller (MTAIC) is capable of rejecting unwanted RF harmonics of the nearby on-board active components. MTAIC improves the capacity of GPS reception leaving hardware integration engineering without the need of hardware changes. LadyBird-3 cancels up to 12 independent channels continuous interference wave.

## 1.5 1PPS

LadyBird-3 generates a pulse\_per\_second signal (1 PPS). It is an electrical signal which precisely indicates the start of a second with the accuracy of  $\pm 10$ ns RMS.

In general, 1 PPS signals are used to provide precise timekeeping and time measurement to the system. It is commonly used for timekeeping in computers which may involve with the NTP protocol.

LadyBird-3 generates highly accurate 1PPS based timing method to synchronize GPS positioning time after obtained 3D-Fix. 1PPS output at power on is available through firmware customization service.

## 1.6 AGPS Support for Fast TTFF(EPO in flash™)

The AGPS (EPO in flash™) supply the predicated Extended Prediction Orbit data to speed TTFF. Users can download the EPO data to GPS engine from the FTP server via internet or wireless network. The GPS engine of the module will use the EPO data to assist position calculation when the navigation information from satellites is not enough as is the case of weak signal. For more details on EPO, visit our website.

## 1.7 EASY™

Embedded Assist System (EASY™) is embedded within the receiver module to assist for quick positioning when not enough information is received from the satellites. With EASY™ technology, the GPS engine is able to calculate and predict up to 3 days single ephemeris automatically when power on. It then saves the predicted information onto the memory. So the GPS engine can use this information for positioning later if not enough information received from the satellites. This function will be helpful for TTFF improvement to allow positioning even under weak signal condition such as dense urban. Backup power (VBACKUP) is required for this feature.

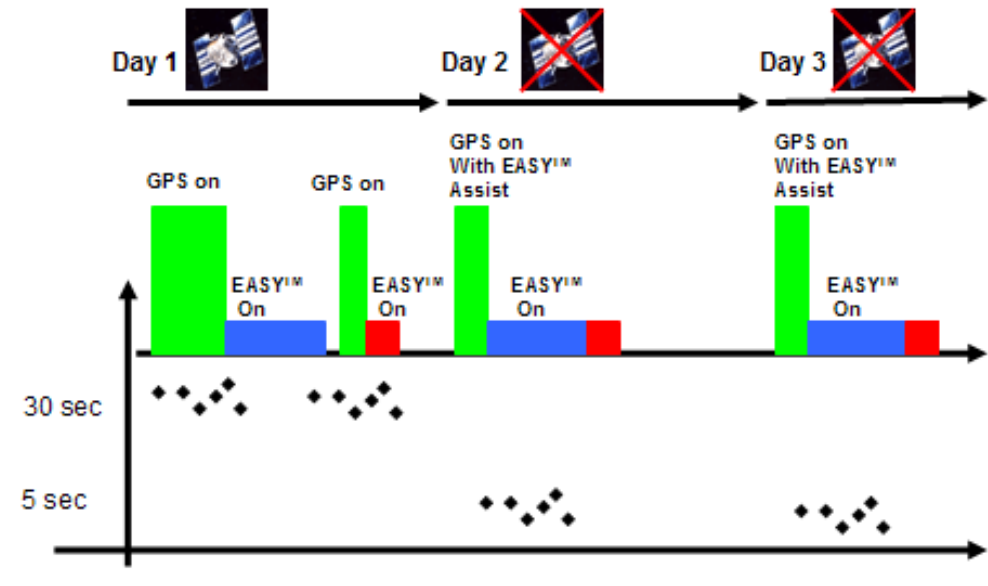

Figure: EASY System operation

Figure show that when GPS device obtained the satellite information from GPS satellites, the GPS engine automatically pre-calculates to predict orbits for 3 extended days.



## 1.8 AlwaysLocate™

LadyBird-3 uses AlwaysLocate™(Advance Power Periodic Mode) modes to achieve power saving by adaptively adjust the on/off time to achieve balance between positioning accuracy and power consumption according to the environmental and motion conditions to achieve best power conservation.

The following figure gives some insight on power saving under different use cases when AlwaysLocate™ mode is enabled. For command detail, please contact our sales staff at [sales@gtop-tech.com](mailto:sales@gtop-tech.com).

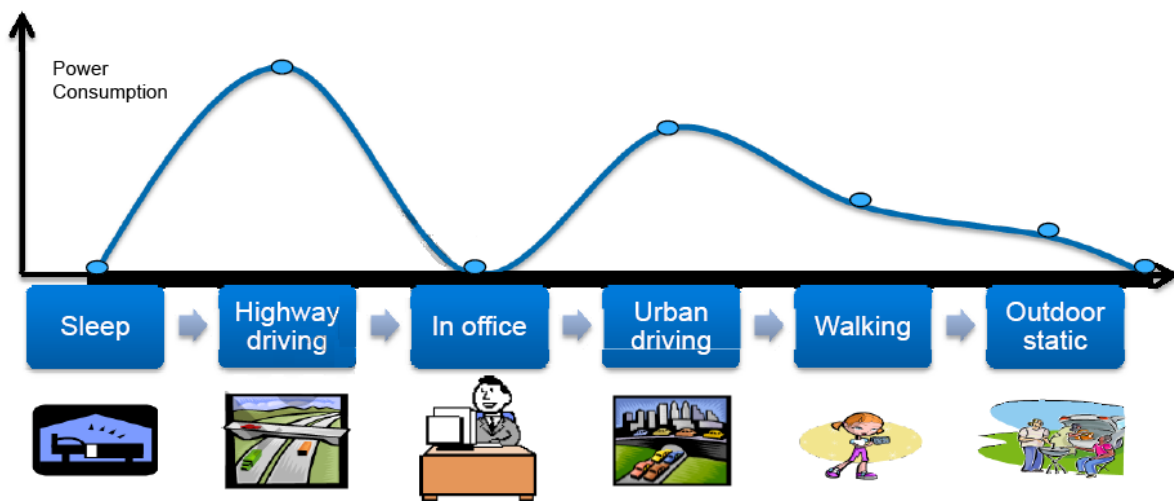

## 1.9 LOCUS

When LOCUS (Embedded Logger Function) feature is enabled, the receiver module becomes a logger capable device. It does not need a host or external flash to log GPS data, such as data format: UTC, latitude, longitude, valid, checksum. The maximum constant log duration can be up to 2 days under AlwaysLocate™ condition.

## 2. Specifications

### 2.1 Mechanical Dimension

Dimension:(Unit: mm, Tolerance: +/- 0.2mm)

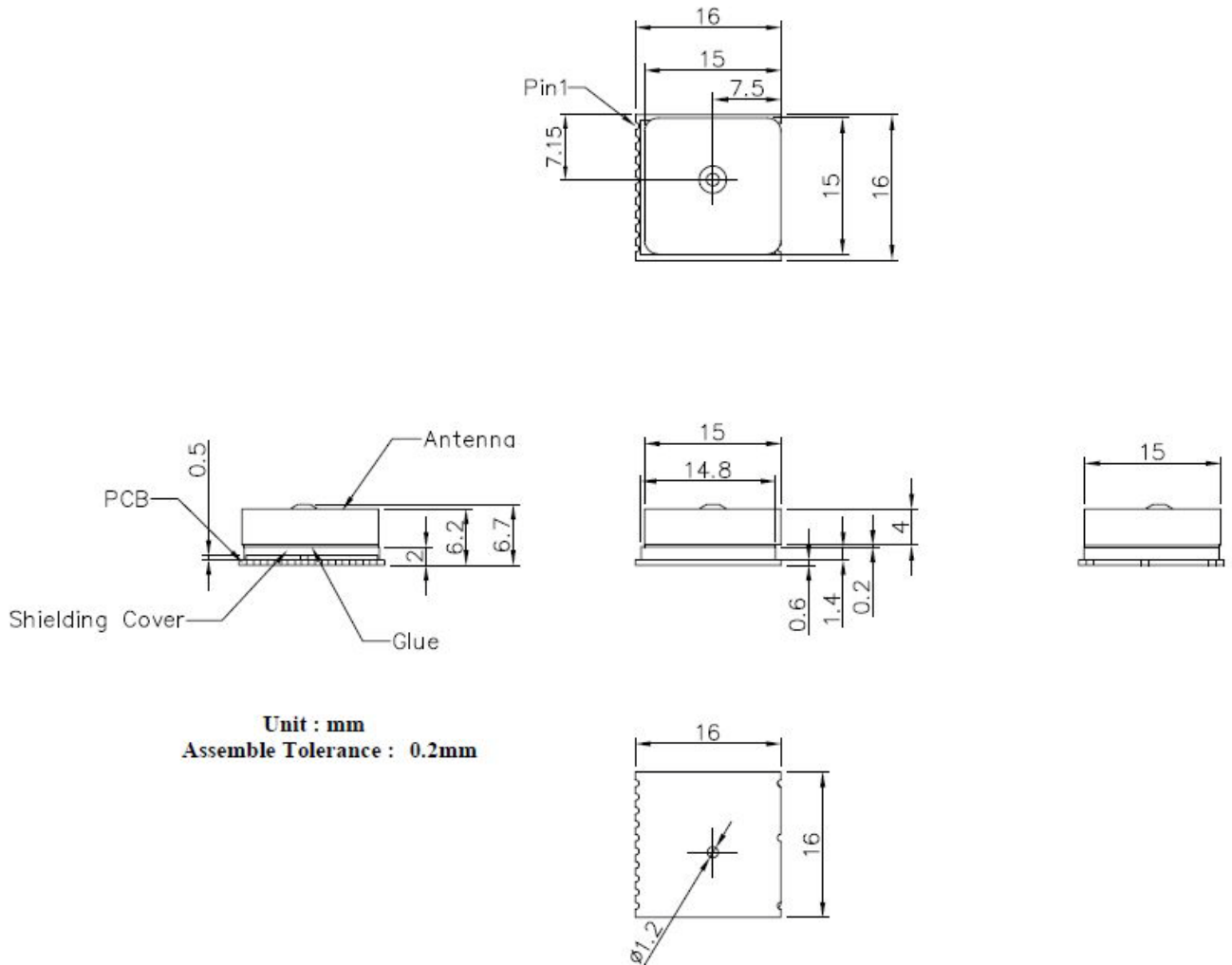

## 2.2 Recommended PCB pad Layout

(Unit: mm, Tolerance:0.1mm)

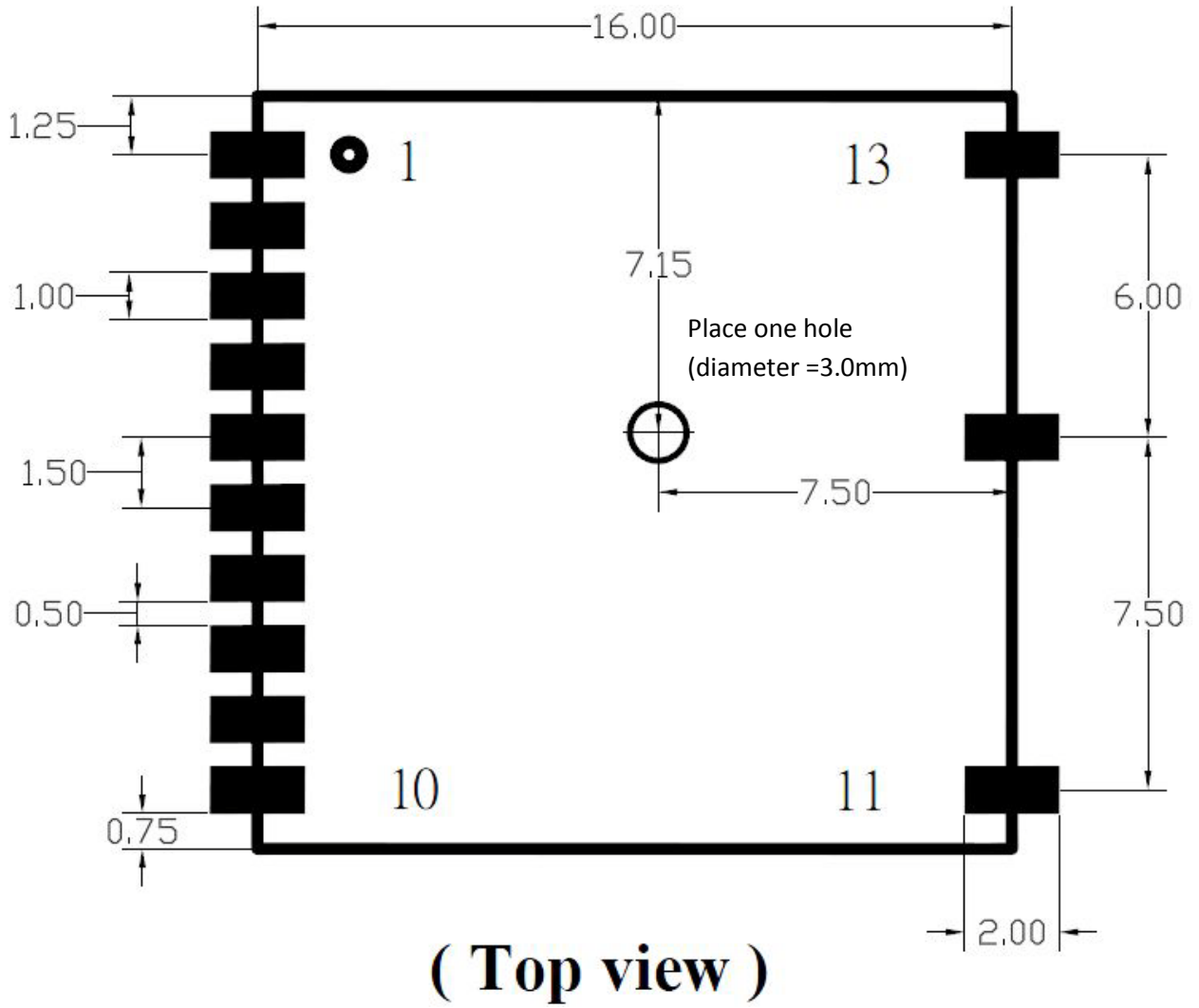

## 2.3 Pin Configuration

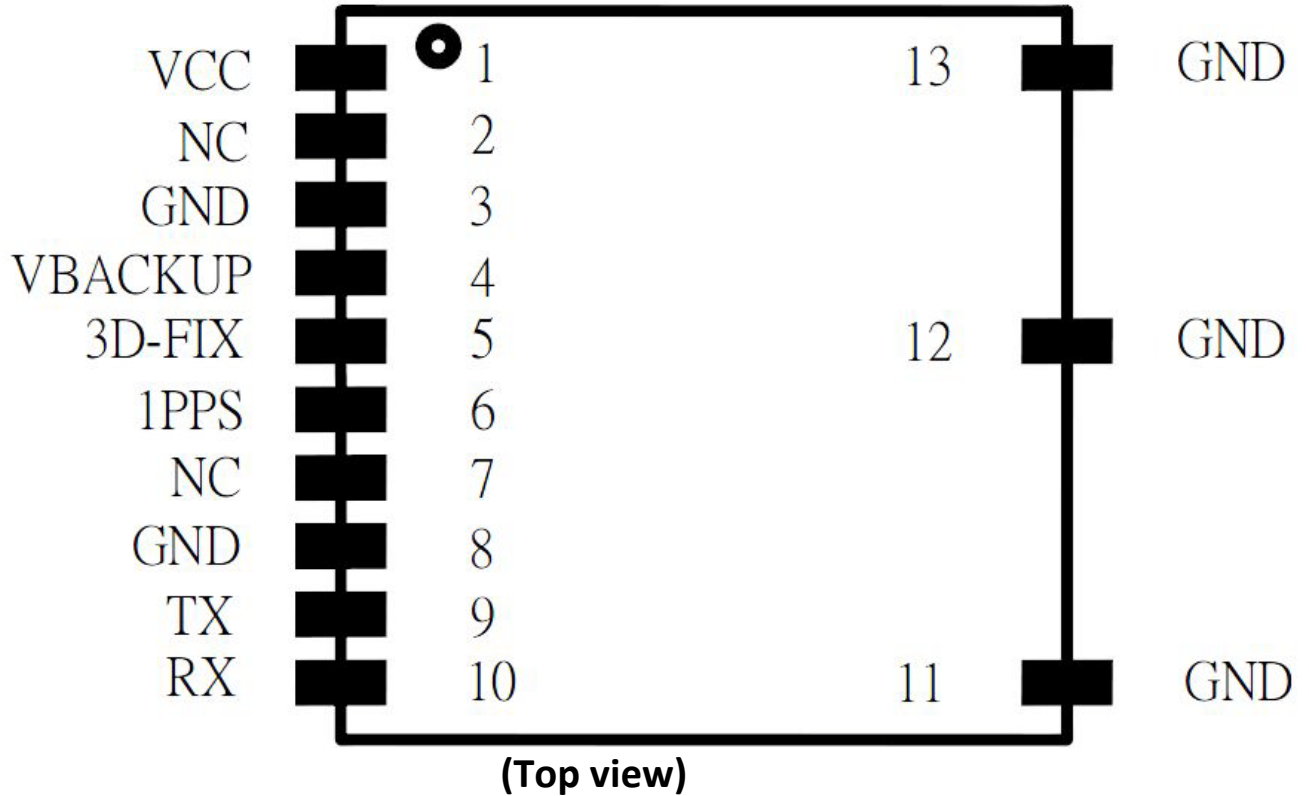

## 2.4 Pin Assignment

Pin	Name	I/O	Description
1	VCC	PI	MainDC power input
2	NC	—	Not connected
3	GND	P	Ground
4	VBACKUP	PI	Backup power input
5	3D-FIX	O	3D-fix indicator
6	1PPS	O	1PPS Time Mark Output 2.8V CMOS Level
7	NC	—	Not connected
8	GND	P	Ground
9	TX	O	Serial data output ofNMEA
10	RX	I	Serial data input for firmware update
11	GND	P	Ground
12	GND	P	Ground
13	GND	P	Ground

## 2.5 Description of I/O Pin

### VCC (Pin1)

The main DC power supply of the module. The voltage should be kept between from 3.0V to 4.3V (**Typical: 3.3V**). **The Vcc ripple must be controlled under 50mV<sub>pp</sub>**

### NC (Pin2 and Pin7)

These are NC pins, they are not connected.

### GND (Pin3 and Pin8)

Ground

### VBACKUP (Pin4)

This connects to the backup power of the GPS module. Power source (such as battery) connected to this pin will help the GPS chipset in keeping its internal RTC running when the main power source is turned off. The voltage should be kept between **2.0V~4.3V. Typical 3.0V.**

**IF VBACKUP power were not reserved, the GPS module will perform a lengthy cold start each time it is powered on as previous satellite information is not retained and needs to be re-transmitted.**

If not used, leave this pin floating.

### 3D-FIX (Pin5)

The 3D-FIX is assigned as a fix flag output. The timing behavior of this pin can be configured by custom firmware for different applications (Example: waking up host MCU).

If not used, leave this pin floating.

- Before 2D Fix

The pin should continuously output signal of one-second high and one-second low.

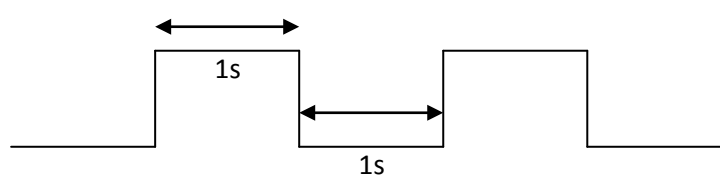



- After 2D or 3D Fix  
The pin should output a constant low signal.

Low \_\_\_\_\_

### **1PPS (Pin6)**

This pin provides one pulse-per-second signal output which synchronizes to the precise GPS time clock.

If not used, leave this pin floating.

### **TX (Pin9)**

This is the UART transmitter of the module. It outputs the GPS information for application.

### **RX (Pin10)**

This is the UART receiver of the module. It is used to receive software commands and firmware update.

## 2.6 Specification

	Description
<b>GPS Solution</b>	MTK MT3339
<b>Frequency</b>	L1, 1575.42MHz
<b>Sensitivity</b>	Acquisition: -148dBm, cold start Reacquisition: -163dBm, Hot start Tracking: -165dBm
<b>Channel</b>	66 channels
<b>TTF</b>	Hot start: 1 second typical Warm start: 33 seconds typical Cold start: 35 seconds typical (No. of SVs>4, C/N>40dB, PDop<1.5)
<b>Position Accuracy</b>	Without aid:3.0m(50% CEP) DGPS(SBAS(WAAS,EGNOS,MSAS,GAGAN*)):2.5m(50% CEP)
<b>Velocity Accuracy</b>	Without aid : 0.1m/s DGPS(SBAS(WAAS,EGNOS,MSAS,GAGAN*)):0.05m/s
<b>Acceleration Accuracy</b>	Without aid:0.1 m/s <sup>2</sup> DGPS(SBAS(WAAS,EGNOS,MSAS,GAGAN*)):0.05m/s <sup>2</sup>
<b>Timing Accuracy(1PPS Output)</b>	±10ns RMS
<b>Altitude</b>	Maximum 18,000m (60,000 feet)
<b>Velocity</b>	Maximum 515m/s (1000 knots)
<b>Acceleration</b>	Maximum 4G
<b>Update Rate</b>	1Hz (default), maximum 10Hz
<b>Baud Rate</b>	9600 bps (default)
<b>DGPS</b>	SBAS(default) [QZSS,WAAS, EGNOS, MSAS,GAGAN*]
<b>Power Supply</b>	VCC: 3.0V to 4.3V; VBACKUP: 2.0V to 4.3V
<b>CurrentConsumption @ 3.3V,1Hz Update Rate</b>	25mA acquisition, 20mA tracking
<b>Backup PowerConsumption@ 3V</b>	7uA(TYP)
<b>Power Saving (Periodic)</b>	Standby mode : 180uA(TYP)
<b>Working Temperature</b>	-40 °C to +85 °C
<b>Dimension</b>	16 x 16x 6.2mm, SMD
<b>Weight</b>	6g

\*GAGAN will be supported.

## 2.7 Absolute Maximum Ratings

The voltage applied for VCC should not exceed 4.3VDC.

	Symbol	Min.	Typ.	Max.	Unit
<b>Power Supply Voltage</b>	VCC	3.0	3.3	4.3	V
<b>Backup battery Voltage</b>	VBACKUP	2.0	3.0	4.3	V

## 2.8 Operating Conditions

	Condition	Min.	Typ.	Max.	Unit
<b>Operation supply Ripple Voltage</b>	—	—	—	50	mVpp
<b>RX0 TTL H Level</b>	—	2.0	—	VCC	V
<b>RX0 TTL L Level</b>	—	0	—	0.8	V
<b>TX0 TTL H Level</b>	—	2.4	—	2.8	V
<b>TX0 TTL L Level</b>	—	0	—	0.4	V



## 3. Protocols

### 3.1 NMEA Output Sentences

**Table-1** lists each of the NMEA output sentences specifically developed and defined by MTK for use within MTK products

Table-1: NMEA Output Sentence	
Option	Description
GGA	Time, position and fix type data.
GSA	GPS receiver operating mode, active satellites used in the position solution and DOP values.
GSV	The number of GPS satellites in view satellite ID numbers, elevation, azimuth, and SNR values.
RMC	Time, date, position, course and speed data. The recommended minimum navigation information.
VTG	Course and speed information relative to the ground.

**GGA—Global Positioning System Fixed Data. Time, Position and fix related data**

**Table-2** contains the values for the following example:

\$GPGGA,064951.000,2307.1256,N,12016.4438,E,1,8,0.95,39.9,M,17.8,M,,\*65

Table-2: GGA Data Format			
Name	Example	Units	Description
Message ID	\$GPGGA		GGA protocol header
UTC Time	064951.000		hhmmss.sss
Latitude	2307.1256		ddmm.mmmm
N/S Indicator	N		N→North or S→South
Longitude	12016.4438		dddmm.mmmm
E/W Indicator	E		E→East or W→West
Position Fix Indicator	1		See <b>Table-3</b>
Satellites Used	8		
HDOP	0.95		Horizontal Dilution of Precision
MSL Altitude	39.9	meters	Antenna Altitude above/below mean-sea-level
Units	M	meters	Units of antenna altitude
Geoidal Separation	17.8	meters	
Units	M	meters	Units of geoids separation
Age of Diff. Corr.		second	Null fields when DGPS is not used
Checksum	*65		
<CR><LF>			End of message termination

Table-3: Position Fix Indicator	
Value	Description
0	Fix not available
1	GPS fix
2	Differential GPS fix

### GSA—GNSS DOP and Active Satellites

**Table-4** contains the values for the following example:

\$GPGSA,A,3,29,21,26,15,18,09,06,10,,,,,2.32,0.95,2.11\*00

Table-4: GSA Data Format			
Name	Example	Units	Description
Message ID	\$GPGSA		GSA protocol header
Mode 1	A		See <b>Table-5</b>
Mode 2	3		See <b>Table-6</b>
Satellite Used	29		SV on Channel 1
Satellite Used	21		SV on Channel 2
....	....	....	....
Satellite Used			SV on Channel 12
PDOP	2.32		Position Dilution of Precision
HDOP	0.95		Horizontal Dilution of Precision
VDOP	2.11		Vertical Dilution of Precision
Checksum	*00		
<CR><LF>			End of message termination

Table-5: Mode 1	
Value	Description
M	Manual—forced to operate in 2D or 3D mode
A	2D Automatic—allowed to automatically switch 2D/3D

Table-6: Mode 2	
Value	Description
1	Fix not available
2	2D (< 4 SVs used)
3	3D ( $\geq$ 4 SVs used)

### GSV—GNSS Satellites in View

Table-7 contains the values for the following example:

\$GPGSV,4,1,15,29,36,029,42,21,46,314,43,26,44,020,43,15,21,321,39\*7D

\$GPGSV,4,2,15,18,26,314,40,09,57,170,44,06,20,229,37,10,26,084,37\*77

\$GPGSV,4,3,15,07,,,26\*73

Table-7: GSV Data Format			
Name	Example	Units	Description
Message ID	\$GPGSV		GSV protocol header
Number of Messages	4		(Depending on the number of satellites tracked, multiple messages of GSV data may be required.) <sup>(Note 4)</sup>
Message Number	1		
Satellites in View	15		
Satellite ID	29		Channel 1 (Range 1 to 32)
Elevation	36	degrees	Channel 1 (Maximum 90)
Azimuth	029	degrees	Channel 1 (True, Range 0 to 359)
SNR (C/No)	42	dBHz	Range 0 to 99, (null when not tracking)
....	....	....	....
Satellite ID	15		Channel 4 (Range 1 to 32)
Elevation	21	degrees	Channel 4 (Maximum 90)
Azimuth	321	degrees	Channel 4 (True, Range 0 to 359)
SNR (C/No)	39	dBHz	Range 0 to 99, (null when not tracking)
Checksum	*7D		
<CR><LF>			End of message termination

(Note4):The maximum every GSV sentence only include information for 4 SVs.

## RMC—Recommended Minimum Navigation Information

**Table-8** contains the values for the following example:

\$GPRMC,064951.000,A,2307.1256,N,12016.4438,E,0.03,165.48,260406,3.05,W,A\*2C

Table-8: RMC Data Format			
Name	Example	Units	Description
Message ID	\$GPRMC		RMC protocol header
UTC Time	064951.000		hhmmss.sss
Status	A		A→data valid or V→data not valid
Latitude	2307.1256		ddmm.mmmm
N/S Indicator	N		N→North or S→South
Longitude	12016.4438		dddmm.mmmm
E/W Indicator	E		E→East or W→West
Speed over Ground	0.03	knots	
Course over Ground	165.48	degrees	True
Date	260406		ddmmyy
Magnetic Variation	3.05, W	degrees	E→East or W→West (Needs GlobalTop Customization Service)
Mode	A		A→ Autonomous mode D→Differential mode E→Estimated mode
Checksum	*2C		
<CR><LF>			End of message termination

**VTG—Course and speed information relative to the ground**

**Table-9** contains the values for the following example:

\$GPVTG,165.48,T,,M,0.03,N,0.06,K,A\*37

Table-9: VTG Data Format			
Name	Example	Units	Description
Message ID	\$GPVTG		VTG protocol header
Course	165.48	degrees	Measured heading
Reference	T		True
Course		degrees	Measured heading
Reference	M		Magnetic Variation (Needs GlobalTop Customization Service)
Speed	0.03	knots	Measured horizontal speed
Units	N		Knots
Speed	0.06	km/hr	Measured horizontal speed
Units	K		Kilometers per hour
Mode	A		A → Autonomous mode D → Differential mode E → Estimated mode
Checksum	*37		
<CR><LF>			End of message termination

## 3.2 MTK NMEA Command Protocols

### Packet Type:

103 PMTK\_CMD\_COLD\_START

### Packet Meaning:

Cold Start : Don't use Time, Position, Almanacs and Ephemeris data at re-start.

### Example:

\$PMTK103\*30<CR><LF>

## 3.3 Firmware Customization Services

GlobalTop also offers flexible, value-adding GPS firmware customization services that maximize the overall system efficiencies and power consumptions. To find out the latest features like Binary Mode, One-Sentence Output, Geo-fencing and Last Position Retention, please visit our website at [www.gtop-tech.com](http://www.gtop-tech.com).

Note that not all firmware customization services listed below are supported for all products. Please contact GlobalTop sales representatives or technical support for more details.



**GlobalTop Firmware Customization Services**

- ASPS**  
fast position fix with preloaded ephemeris
- BINARY MODE**  
output position in binary format for increase efficiency
- PERIODIC MODE**  
saves battery by powering off unused components
- DISTANCE CALCULATION**  
calculates line of sight distance between receiver and other points of interest
- TIMING MODE**  
advanced 1PPS control for synchronization equipments
- MAGNETIC VARIATION**  
Outputs degree of magnetic variation & measured magnetic heading
- GEO-FENCING**  
variable sized circular and polygonal perimeter for in/out of zone warning
- 10 HZ UPDATE**  
fast refresh rate for high speed applications
- LAST POSITION RETENTION**  
outputs last known position coordinates after losing GPS satellite fix
- ONE SENTENCE**  
decreases calculation load on processor by simplifying output NMEA sentences
- EXTENDED ALTITUDE**  
Enables GPS/GNSS module to work beyond 60,000ft (~18,000m) to 164,000ft

## 4. Reference Design

This section introduces the reference schematic design for best performance. Additional tips and cautions on design are well documented in the Application Note which is available upon request.

### 4.1 Reference Design Circuit

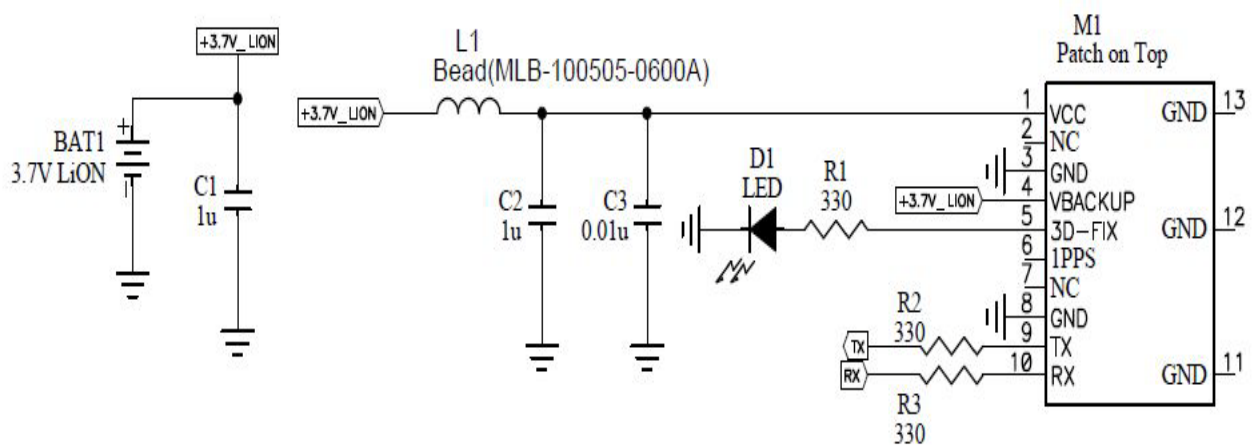

#### Note:

1. Ferrite bead L1 is added for power noise reduction.
2. C2 and C3 bypass capacitors should be placed in proximity to the module.  
For C1, the value chosen depends on the amount of system noise, ranging from 1µF to 100µF is reasonable.
3. Damping resistors R2 and R3 can be modified based on system application for EMI.
4. If you need more support and information on antenna implementation, please contact us at [atsales@gtop-tech.com](mailto:atsales@gtop-tech.com).



## 5. Packing and Handling

---

LadyBird-3, like any other SMD devices, is sensitive to moisture, electrostatic discharge, and temperature. By following the standards outlined in this document for GlobalTop module storage and handling, the chances of them being damaged during production set-up can be reduced. This section will walk you through the basics on how GlobalTop packages its modules to ensure they arrive at their destination without any damages and deterioration to performance quality. It includes cautionary notes for prior to the surface mount process.

 **Please read the sections II to V carefully to avoid permanent damages due to moisture intake.**

 **GPS receiver modules contain highly sensitive electronic circuits and are electronic sensitive devices. Improper handling without ESD protections may lead to permanent damages to the modules. Please read section VI for more details.**

### 5.1 Moisture Sensitivity

GlobalTop modules are moisture sensitive, and must be pre-baked before going through the solder reflow process. It is important to know that:

**GlobalTop GPS modules must complete solder reflow process in 72 hours after pre-baking.**

This maximum time is otherwise known as “Floor Life”

If the waiting time has exceeded 72 hours, it is possible for the module to suffer damages during the solder reflow process such as cracks and delamination of the SMD pads due to excess moisture pressure.

## 5.2 Tape Reel Packing Information

250pcs/Reel

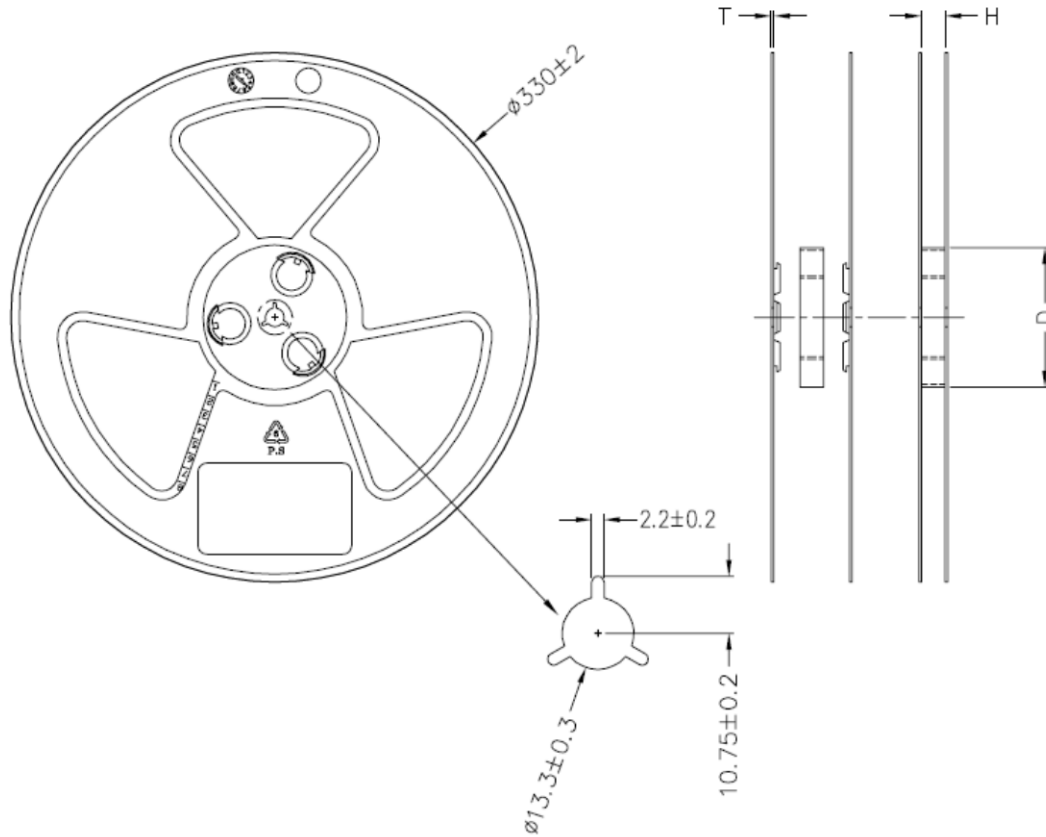

Spec: H: $32.5 \pm 1.5$ , T: $2.2 \pm 0.2$ , D: $99 \pm 1.5$

Note: 13" Reel, Material: P.S

Unit: (mm)

Figure 1: Reel Dimension

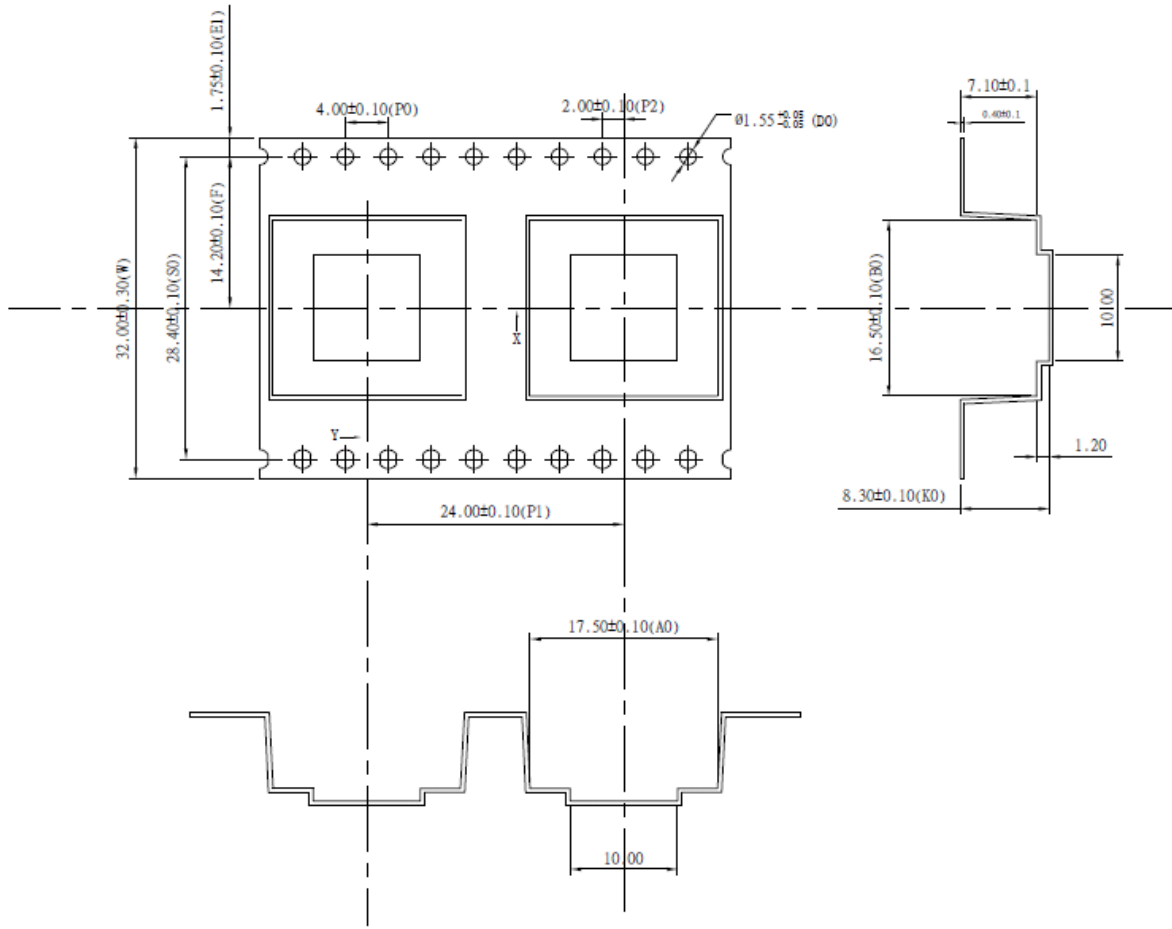

A0	17.5±0.10
B0	16.5±0.10
K0	8.3±0.10

Unit: (mm)

Figure 2: Tape Dimension

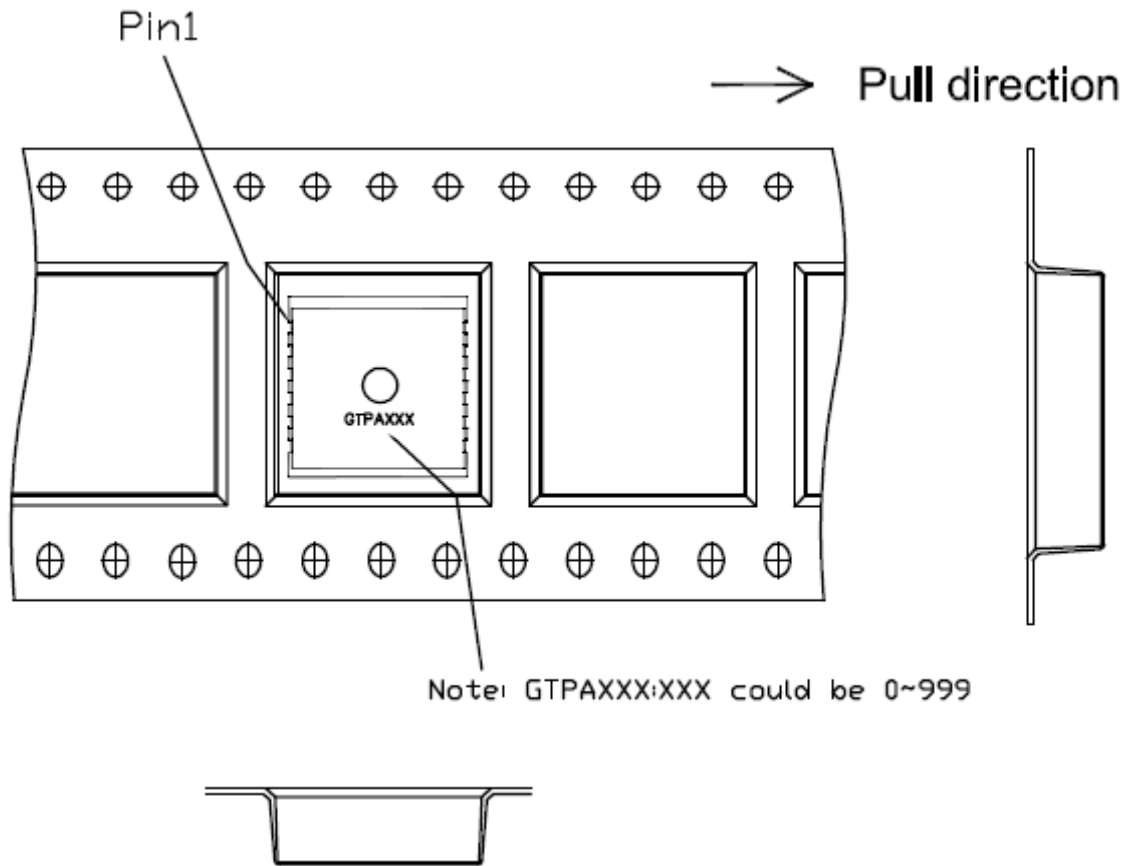

## Roll up direction:

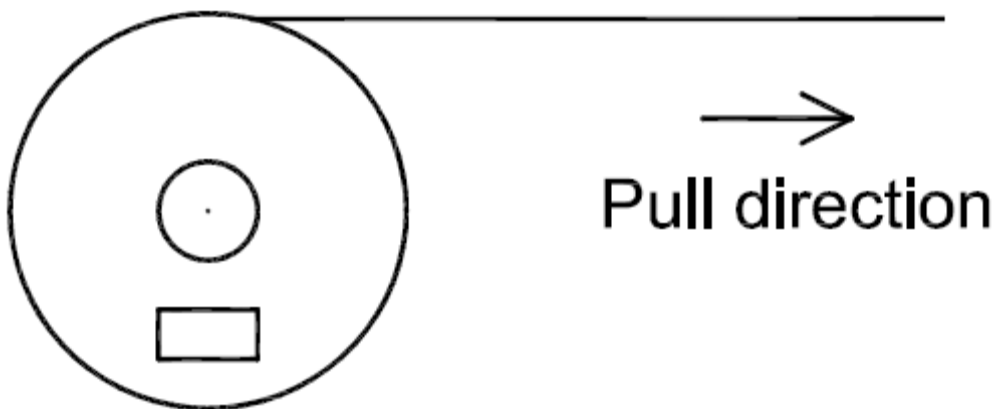

Figure 3: Tape Orientation

The moisture color coded card provides an insight to the relative humidity in percentage (RH). When the GPS modules are taken out, it should be around or lower than 30% RH level.

Outside each electrostatic bag is a caution label for moisture sensitive device.

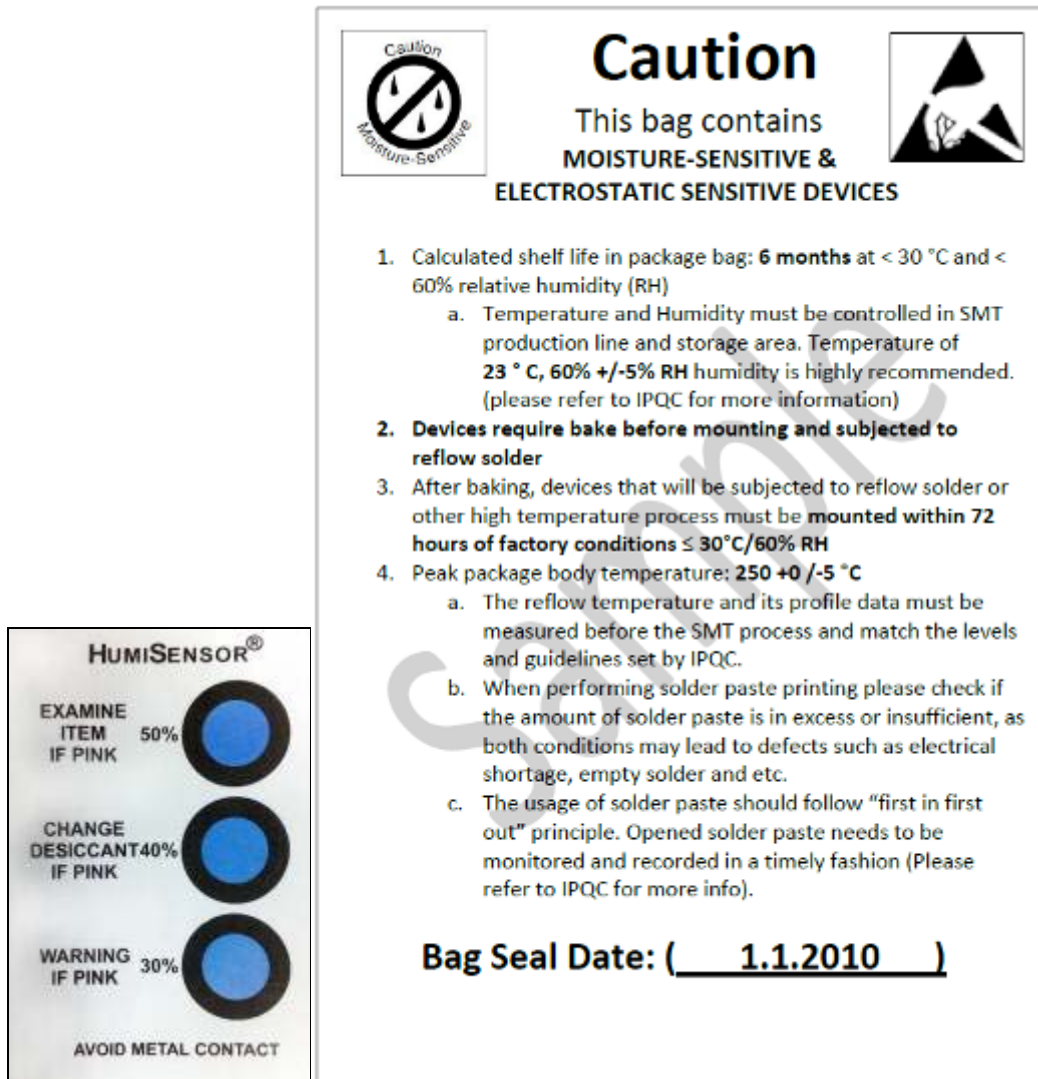

Figure 4: Example of moisture color coded card and caution label

## 5.3 Storage and Floor Life Guideline

Since GlobalTop modules must undergo solder-reflow process in 72 hours after it has gone through pre-baking procedure, therefore if it is not used by then, it is recommended to store the GPS modules in dry places such as dry cabinet.

The approximate shelf life for GlobalTop GPS modules packages is 6 months from the bag seal date, when store in a non-condensing storage environment (<30°C/60% RH)

 **It is important to note that it is a required process for GlobalTop GPS modules to undergo pre-baking procedures, regardless of the storage condition.**

## 5.4 Drying

When GPS modules exposed to high temperature of solder reflow, the moisture vapor pressure inside the GPS modules increase greatly. In order to prevent internal delaminating, cracking of the device or the “popcorn” phenomenon, to undergo pre-baking procedure become necessary prior to any high temperature or solder reflow process.

The recommended baking time for GlobalTop GPS module is as follows:

- ✓ **60°C for 8 to 12 hours**

Once baked, the module’s floor life will be “reset”, and has additional 72 hours in normal factory condition to undergo solder reflow process.

 **Please limit the number of times the GPS modules undergoes baking processes as repeated baking process has an effect of reducing the wetting effectiveness of the SMD pad contacts. This applies to all SMT devices.**

 **Oxidation Risk: Baking SMD packages may cause oxidation and/or intermetallic growth of the terminations, which if excessive, can result in solderability problems during board assembly. The temperature and time for baking SMD packages are therefore limited by solderability considerations. The cumulative bake time at a temperature greater than 90°C and up to 125°C shall not exceed 96 hours. Bake temperatures higher than 125°C are not allowed.**

## 5.5 ESD Handling



**Please carefully follow the following precautions to prevent severe damage to GPS modules.**

GlobalTop GPS modules are sensitive to electrostatic discharges, and thus are Electrostatic Sensitive Devices (ESD). Careful handling of the GPS modules particularly to its patch antenna (if included) and RF\_IN pin. Please follow the standard ESD safety practices stated below:

- ✓ Unless there is a galvanic coupling between the local GND and the PCB GND, then the first point of contact when handling the PCB shall always be between the local GND and PCB GND.
- ✓ Before working with RF\_IN pin, please make sure the GND is connected
- ✓ When working with RF\_IN pin, do not contact any charged capacitors or materials that can easily develop or store charges such as patch antenna, coax cable, soldering iron.
- ✓ Please do not touch the mounted patch antenna to prevent electrostatic discharge from the RF input
- ✓ When soldering RF\_IN pin, please make sure to use an ESD safe soldering iron tip.

## 6. Reflow Soldering Temperature Profile

The following reflow temperature profile was evaluated by GlobalTop and has been proven to be reliable qualitatively. Please contact us beforehand if you plan to solder this component using a deviated temperature profile as it may cause significant damage to our module and your device.

All the information in this sheet can only be used only for Pb-free manufacturing process.

### 6.1 SMT Reflow Soldering Temperature Profile (Reference Only)

Average ramp-up rate (25 ~ 150°C): 3°C/sec. max.

Average ramp-up rate (270°C to peak): 3°C/sec. max.

Preheat: 175 ± 25°C, 60 ~ 120 seconds

Temperature maintained above 217°C: 60~150 seconds

Peak temperature: 250 +0/-5°C, 20~40 seconds

Ramp-down rate: 6°C/sec. max.

Time 25°C to peak temperature: 8 minutes max.

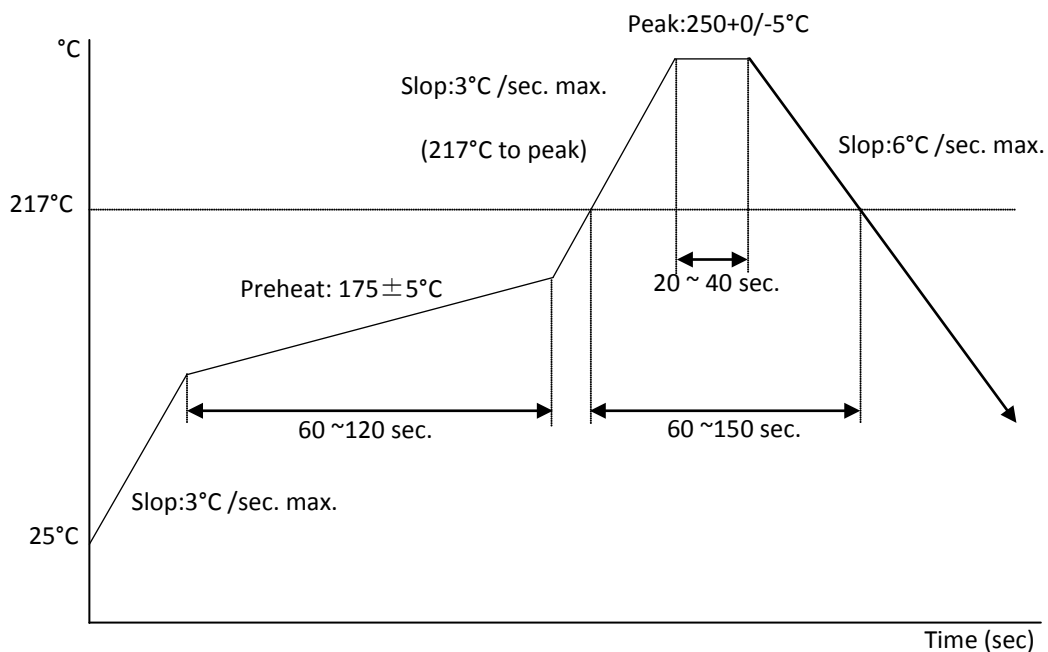



	Details	Suggestions	Notes
1	Before proceeding with the reflow-soldering process, the GPS module must be pre-baked.	Pre-bake Time: 6 Hours @ 60°±5°C or 4 Hours @ 70°±5°C	<b>The maximum tolerated temperature for the tray is 100°C.</b>  <b>After the pre-baking process, please make sure the temperature is sufficiently cooled down to 35°C or below in order to prevent any tray deformation.</b>
2	Because PCBA (along with the patch antenna) is highly endothermic during the reflow-soldering process. Extra care must be paid to the GPS module's solder joints if any signs of cold weld(ing) or false welding.	The parameters of the reflow temperature must be set accordingly to module's reflow-soldering temperature profile.	<b>Double check to see if the surrounding components around the GPS module are displaying symptoms of cold weld(ing) or false welding.</b>
3	Special attentions are needed for PCBA board during reflow-soldering to see if there are any symptoms of bending or deformation to the PCBA board, possibly due to the weight of the module. If so, this will cause concerns at the latter half of the production process.	A loading carrier fixture must be used with PCBA if the reflow soldering process is using rail conveyors for the production.	<b>If there is any bending or deformation to the PCBA board, this might causes the PCBA to collide into one another during the unloading process.</b>
4	Before the PCBA is undergoing a reflow-soldering process, the production operators must check with own eyes to see if there are positional offset to the module, because it will be difficult to readjust after the module has gone through reflow-soldering process.	The operators must check with own eyes and readjust the position before reflow-soldering process.	<b>If the operator is planning to readjust the module position, please do not touch the patch antenna while the module is hot in order to prevent rotational offset between the patch antenna and module</b>

**Note:** References to patch antenna is referred to GPS modules with integrated Patch-on-top antennas (PA/Gms Module Series), and may not be applicable to all GPS modules.

	Details	Suggestions	Notes
5	Before handling the PCBA, they must be cooled to 35°C or below after they have undergone a reflow-soldering process, in order to prevent positional shift which may occurred when the module is still hot.	<ol style="list-style-type: none"> <li>One may use electric fans behind the reflow machine to cool them down.</li> <li>Cooling the PCBA can prevent the module from shifting due to fluid effect.</li> </ol>	<b>It is very easy to cause positional offset to the module and its patch antenna when handling the PCBA under high temperature.</b>
6	<ol style="list-style-type: none"> <li>When separating the PCBA panel into individual pieces using the V-Cut process, special attentions are needed to ensure that there are sufficient gap between patch antennas.</li> <li>If V-Cut process is not available and the pieces must be separated manually, please make sure the operators are not using excess force which may cause rotational offset to the patch antennas.</li> </ol>	<ol style="list-style-type: none"> <li>The blade and the patch antenna must have a distance gap greater than 0.6mm.</li> <li>Do not use patch antenna as the leverage point when separating the panels by hand.</li> </ol>	<ol style="list-style-type: none"> <li><b>Test must be performed first to determine if V-Cut process is going to be used. Ensure that there is enough space between the blade and the patch antenna so that they do not touch one another.</b></li> <li><b>An uneven amount of manual force applied to the separation will likely to cause positional shift in patch antenna and module.</b></li> </ol>
7	When separating panel into individual pieces during latter half of the production process, special attentions are needed to ensure the patch antennas do not come in contact with one another in order to prevent chipped corners or positional shifts.	Use tray to separate individual pieces.	<b>It is possible to chip corner and/or cause a shift in position if patch antennas come in contact with each other.</b>

**Note:** References to patch antenna is referred to GPS modules with integrated Patch-on-top antennas (PA/Gms Module Series), and may not be applicable to all GPS modules.

### Other Cautionary Notes on Reflow-Soldering Process:

1. Module must be pre-baked **before** going through SMT solder reflow process.
2. The usage of solder paste should follow “First-in-First out” principle. Opened solder paste needs to be monitored and recorded in a timely manner (refer to IPQC standards for related documentation and examples).
3. Temperature and humidity must be controlled within SMT production line and storage area. Temperature of 23°C, 60±5% RH humidity is recommended. (please refer to IPQC standards for related documentation and examples)
4. When performing solder paste printing, please notice if the amount of solder paste is in excess or insufficient, as both conditions may lead to defects such as electrical shortage, empty solder and etc.
5. Make sure the vacuum mouthpiece is able to bear the weight of the GPS module to prevent positional shift during the loading process.
6. Before the PCBA is going through the reflow-soldering process, the operators should check with his/her own eyes to see if there are positional offset to the module.
7. The reflow temperature and its profile data must be measured before the SMT process and match the levels and guidelines set by IPQC.
8. If SMT protection line is running a double-sided process for PCBA, please process GPS module during the second pass only to avoid repeated reflow exposures of the GPS module. Please contact GlobalTop beforehand if you must process GPS module during the 1<sup>st</sup> pass of double-side process.

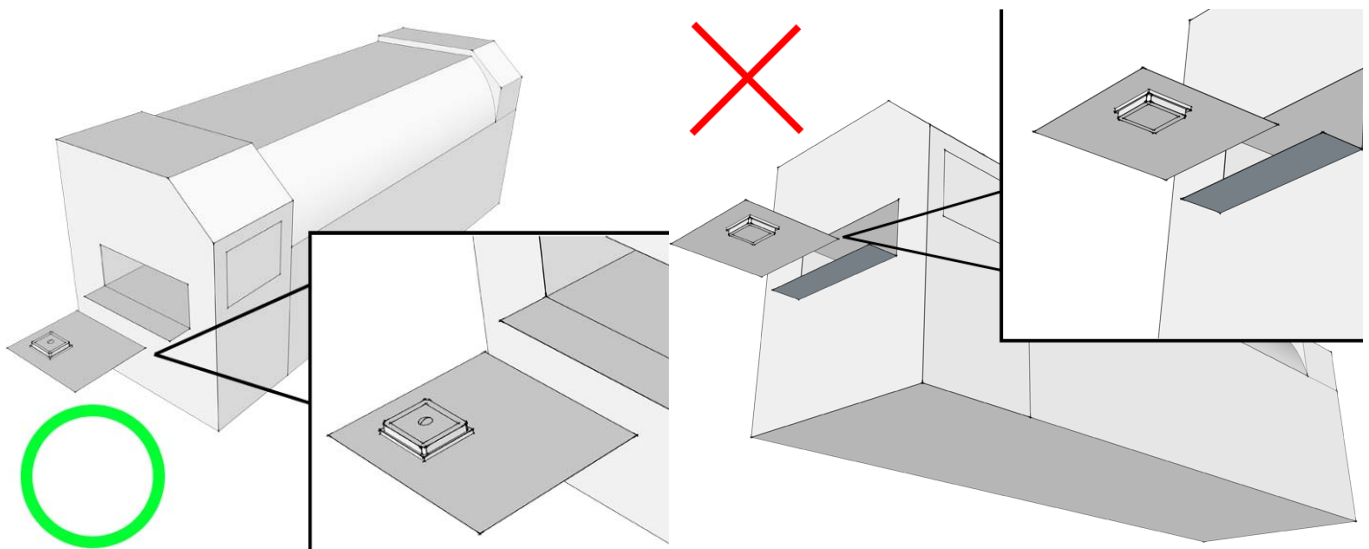

Figure 5: Place GPS module right-side up when running reflow-solder process, do not invert.

## 6.2 Manual Soldering

### Soldering iron:

Heat temperature: under 380°C | Time: under 3 sec.

### Notes:

1. Please do not directly touch the soldering pads on the surface of the PCB board to prevent further oxidation
2. The solder paste must be defrosted to room temperature before use so it can return to its optimal working temperature. The time required for this procedure is unique and dependent on the properties of the solder paste used.
3. The steel plate must be properly assessed before and after use, so its measurement stays strictly within the specification set by SOP.
4. Please watch out for the spacing between soldering joint, as excess solder may cause electrical shortage
5. Please exercise with caution and do not use extensive amount of flux due to possible siphon effects on neighboring components, which may lead to electrical shortage.
6. Please do not use the heat gun for long periods of time when removing the shielding or inner components of the GPS module, as it is very likely to cause a shift to the inner components and will leads to electrical shortage.

## 7. Contact Information

### GlobalTop Technology Inc.

**Address:** No.16 Nan-ke 9th Road Science-based Industrial Park, Tainan 741, Taiwan

**Tel:** +886-6-5051268

**Fax:** +886-6-5053381

**Website:** [www.gtop-tech.com](http://www.gtop-tech.com)

**Email:** [sales@gtop-tech.com](mailto:sales@gtop-tech.com)